

## ASSEMBLY INSTRUCTIONS: FLIP DOOR DESK WITH CPU RACKS (FD-R)

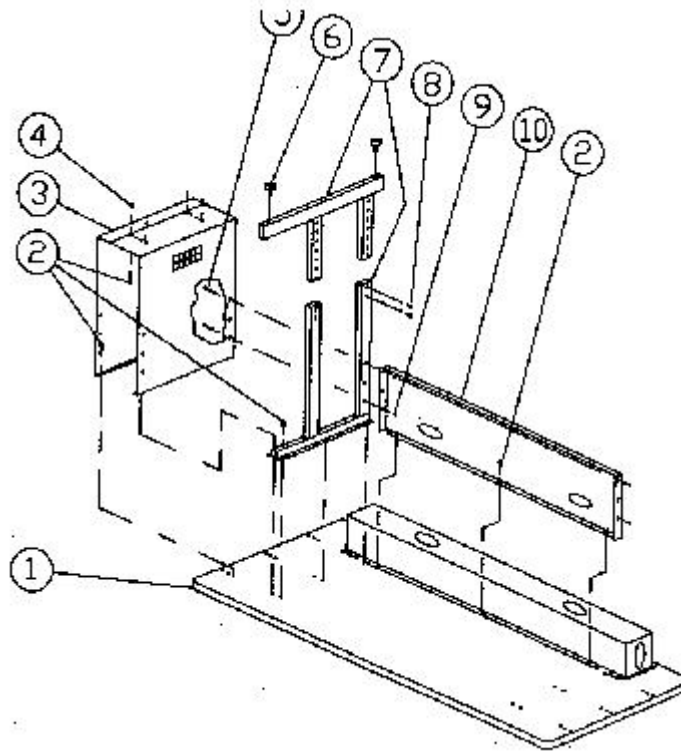

HARDWARE		
QUANTITY	PART NUMBER	DESCRIPTION
4	1010530	FLOOR GLIDE
2	1010535	RUBBER GROMMET
4	1010550	¼-20 LOCKNUT
20	1010555	10/32 X ½" MACHINE SCREW
4	1010565	¼-20 X 1 ½" MACHINE SCREW
8	1010570	¼-20 X ½" HEX HEAD BOLT

### INSTRUCTIONS

1. Lay top upside down on a clean, scratch free surface.
2. Fasten right leg to top as shown using six 10-32 x ½" machine screws. Finger tighten only.
3. Adjust right leg to desired height and fasten bottom to top using four ¼-20 x ½" hex head bolts. Tighten these bolts.
4. Fasten two floor glides to bottom of the right leg.
5. Repeat steps two through four for left leg at the opposite end of the top.
6. Put together the CPU with provided instructions and hardware.
7. Fasten the CPU assembly to top using six 10/32 x ½" machine screws. Finger tighten only. Note: The three inside holes of the CPU assembly will align over top of the three outside holes on the right leg.
8. Repeat steps six and seven at opposite end of top for models FD72R or FD84R.

9. Align the modesty panel over the three mounting holes in top and fasten using three 10/32 x 1/2" machine screws. Finger tighten only.
10. Align holes in the CPU with the holes in the right leg and modesty panel and fasten together using two 1/4-20 x 1 1/2" machine screws and two 1/4-20 locknuts. Do not completely tighten at this time.
11. Repeat step ten at opposite end of the top with left leg.
12. At this time, go back and tighten all fasteners.
13. Align chase over mounting holes in top. Fasten chase to the top using 10/32 x 1/2" machine screws. Tighten these screws once all are in place.
14. If you have purchased optional keyboard trays, assemble the keyboard tray per the separate instructions and hardware provided using mounting option "A" designated in those instructions.
15. If you have purchased optional SR814, assemble per the separate instructions and hardware.
16. Using two or more people, place assembled table upright.
17. Align slots in chase door with the two pins provided at the outside ends of the chase and slide into place.
18. Attach rubber grommets to large holes in wire chase.