



A&D™ ADJUSTABLE HEIGHT LEGS

a product of Paragon Furniture's A&D™ ADJUSTABLE HEIGHT LEGS Series

Thank you for purchasing A&D™ ADJUSTABLE HEIGHT LEGS from Paragon Furniture. Enclosed in the box are the various hardware and components you will need to assemble the product. Review the PARTS LIST below to ensure all the hardware and components are included before you start assembly. Please follow the steps below in order to ensure your product is constructed properly.

If you have any questions throughout this process or with your product after set-up, please contact Paragon Furniture Customer Service at (800) 451-8646.

PARTS LIST



ADJUSTABLE HEIGHT LEGS
Qty:4

10105602



10-32 x 3/4"
phillips screws with washer
Qty:24

101056230



10-32 x 3/16"
phillips screws
Qty:8



Back Pack
Hook
Qty:1

10105602



10-32 x 3/4"
phillips screws
Qty:2
(Non-washer screws
used only to attach
BACK PACK HOOK)



EXPLODED VIEW

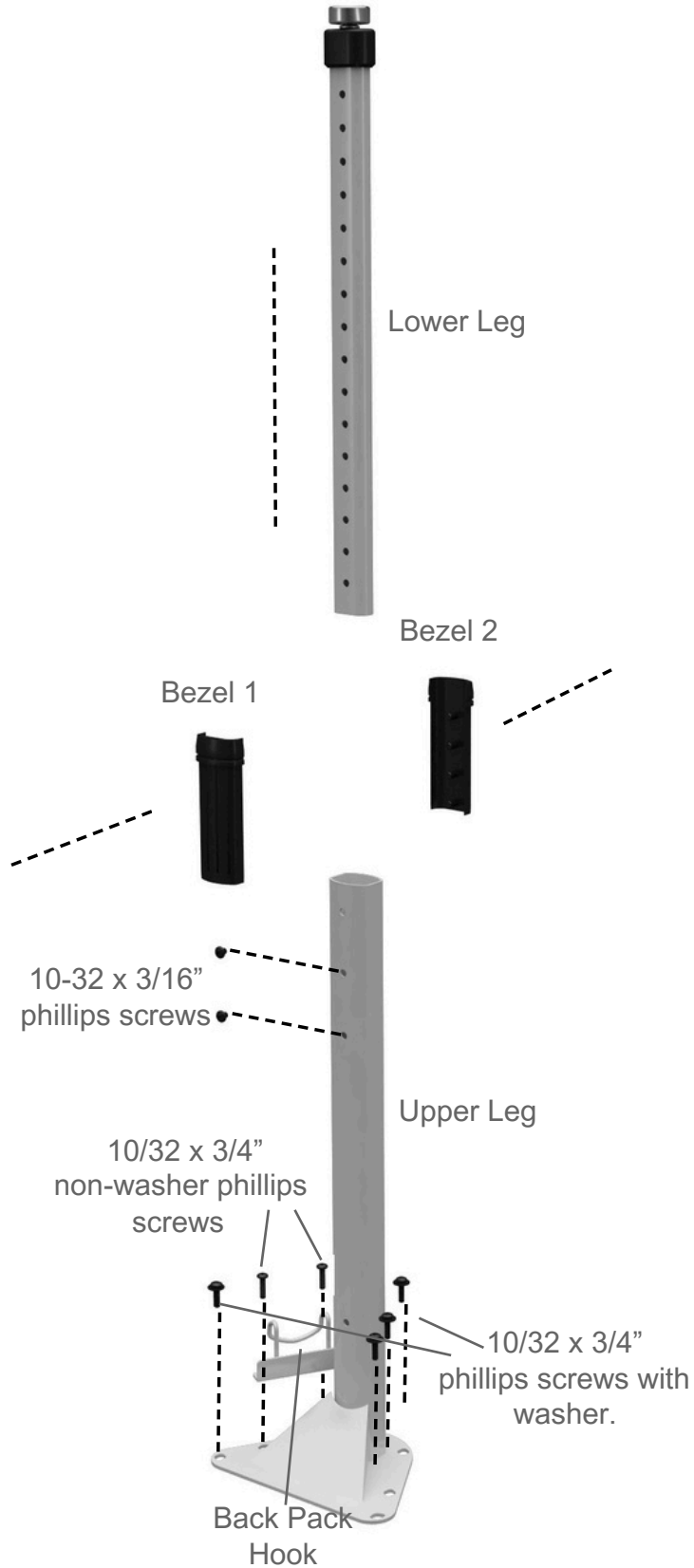



**DO NOT FULLY TIGHTEN HARDWARE
UNTIL AFTER ATTACHING WORKSURFACE.**

STEP 1

Identify leg parts and hardware

Unpack from box (4) adjustable height legs.



Note:

1. The leg lower is inserted into the leg upper at the shortest possible leg length setting.
2. Locate leg assembly hardware kit contained in plastic bag

STEP 2

Identify leg parts and hardware

Manually remove lower leg part from upper part
and remove (2) piece leg bezel

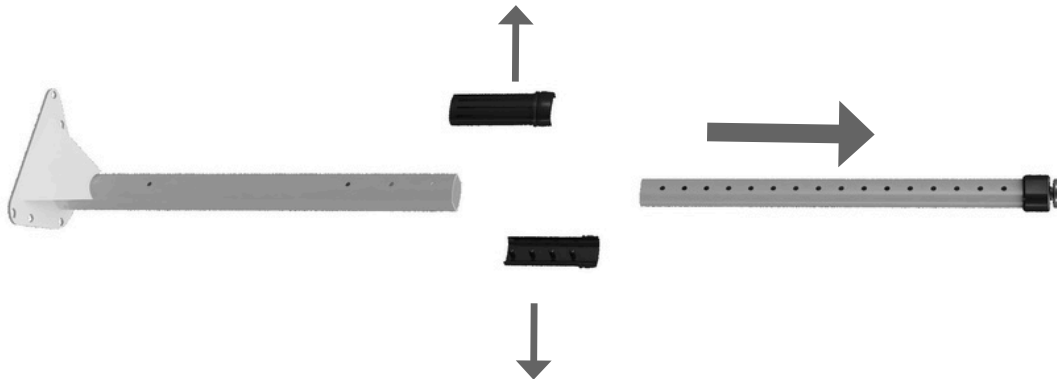

STEP 3

Setting the height of the legs

Reset bezels to hole locations based on overall table top height setting chart found below.

Reinsert leg lower part into leg upper part.



Overall table top height setting guide.

Notes:

1. The chart is based on overall height of table with glides.
2. The chart presents the # of holes in leg lower that are visible between the bottom of bezel and the leg lower end cap

Giraffe Desk Height	24.5"	25.5"	26.5"	27.5"	28.5"	29.5"	30.5"	31.5"	32.5"	33.5"	34.5"	35.5"	36.5"	37.5"	38.5"
Number of Holes Showing on Lower Leg	0	1	2	3	4	5	6	7	8	9	10	11	12	13	14

Adult Desk Height	24.5"	25.5"	26.5"	27.5"	28.5"	29.5"	30.5"	31.5"	32.5"	33.5"	34.5"	35.5"
Number of Holes Showing on Lower Leg	0	1	2	3	4	5	6	7	8	9	10	11

Elementary Desk Height	16.5"	17.5"	18.5"	19.5"	20.5"	21.5"	22.5"	23.5"	24.5"
Number of Holes Showing on Lower Leg	0	1	2	3	4	5	6	7	8

STEP 4

Hardware **VERY IMPORTANT STEP!**

With fingers, start (2) 10-32 x 3/16" screws per leg lower.

Start screws in the (2) holes closest to the fully seated Bezel.

There are 2 other holes higher in the upper leg part; these holes are only to be used if applying a modesty panel.

With manual screwdriver, turn (2) 10-32 x 3/16" screws three to four additional turns.

DO NOT USE POWER DRILL TO APPLY 10-32 x 3/16"
Screws. They will STRIP OUT

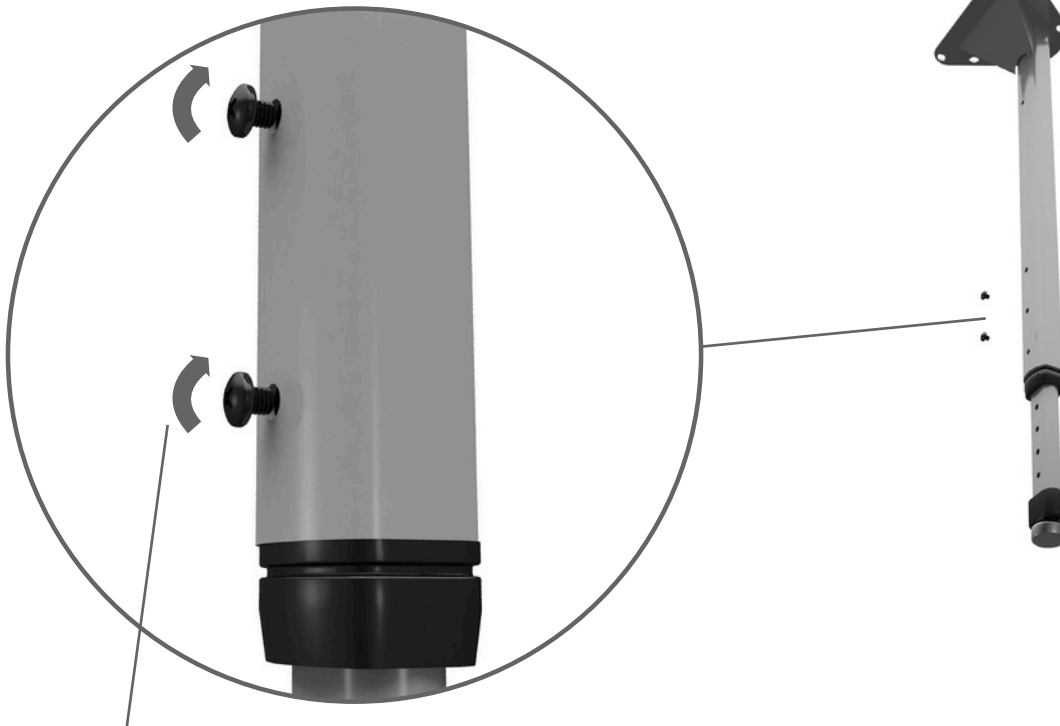

DO NOT USE POWER DRILL TO APPLY
10-32 x 3/16" **phillips** Screws. They will STRIP OUT

STEP 5

Attaching glides and/or casters

Manually apply floor glide to end cap of leg lower. Take care not to use excessive turning force on glide.

If applying casters instead of glides, make adjustment to bezel location based on the previous height chart. Note, the leg lower holes are spaced 1" apart.

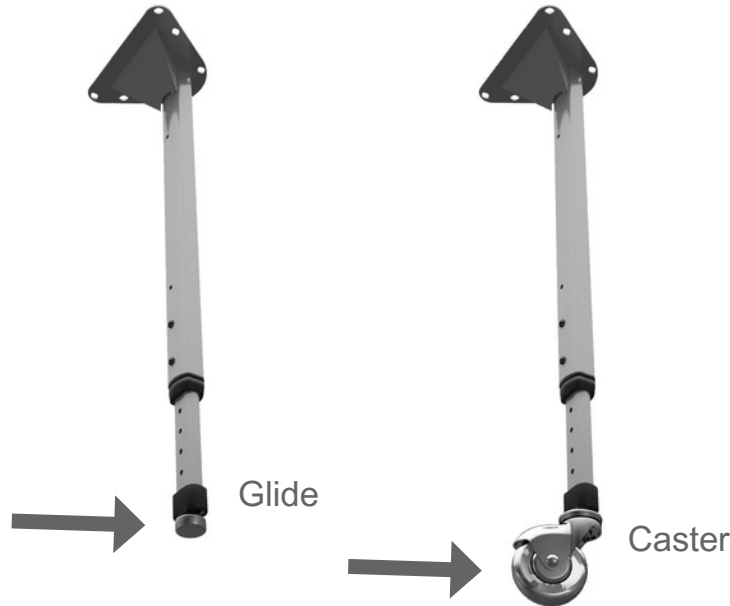

STEP 6

Attaching legs to top **WITHOUT** a Back Pack Hook

With desk/table top placed upside down and resting on clean and non-scratching material, align slots of leg plate with the threaded metal inserts pre-installed into the underside of top. Manually insert (6) 10-32 x 3/4" washer phillips screw per leg through the leg plate slots and into the threaded metal inserts in desk/table top.

AFTER MANUALLY STARTING EACH 10-32 x 3/4" screw, USE POWER DRILL WITH #2 DRILL BIT to complete leg plate-to-top assembly. NOTE: take care to set power drill clutch to deliver high torque. Failing to set clutch appropriately may strip screws.

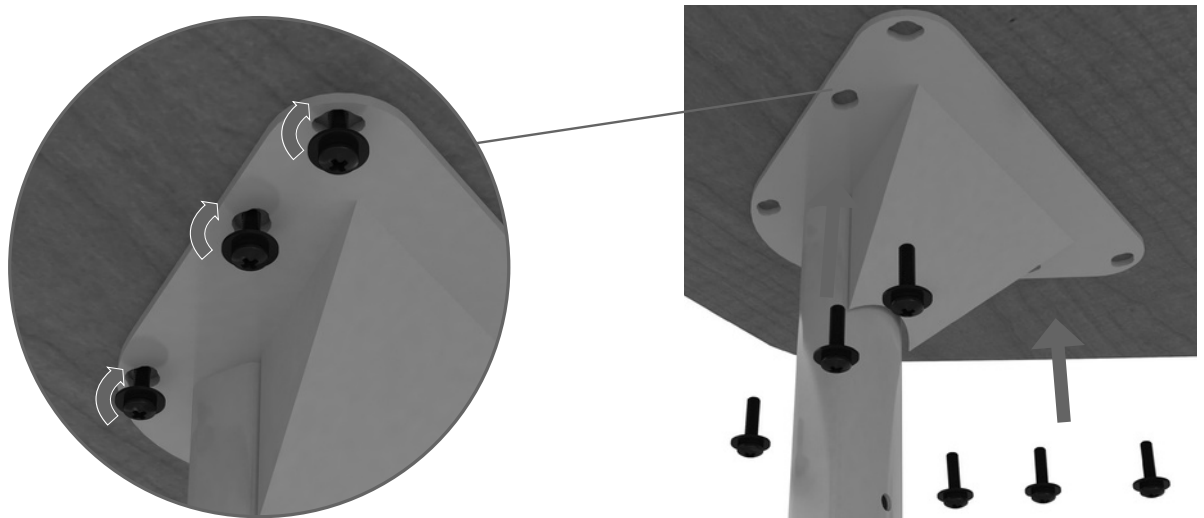

STEP 6

Attaching legs to top **WITH a Back Pack Hook**

With desk/table top placed upside down and resting on clean and non-scratching material, align slots of leg plate with the threaded metal inserts pre-installed into the underside of top. Place back pack hook over (2) outer hole locations. Bend of hook should face outward/toward the student.

Manually insert (2) 10-32 x 3/4" phillips screws through back pack hook, through leg plate and into the threaded metal inserts in desk/table top.

After manually starting each 10-32 x 3/4" washer phillips screws into all non-back pack hook threaded metal inserts, use power drill set to high torque to complete leg plate-to-top assembly. Failing to set drill torque to high may strip screw head or fail to properly fasten leg plate to top.

NOTE: BACK PACK HOOK RECEIVES SCREWS ONLY...NO WASHERS!

