



BUYER RESOURCE GUIDE

PARAGON™
FURNITURE



REACH.

Paragon can effectively furnish about 80% of most school environments. We have a comprehensive collection for Classrooms, Makerspaces, Libraries, and Lounges.

RELEVANCE.

Our furniture reflects the evolving needs of modern learning spaces, with an emphasis on flexibility, mobility, and functionality.

RIGOR.

From concept to creation, we apply the highest standards of quality and durability to every piece of furniture we manufacture.



OUR MISSION

At Paragon Furniture, we believe the future of education is not just in the curriculum, but in the very spaces where learning happens. We're not just making furniture; we're crafting the foundation for vibrant learning communities. Our mission is to elevate the human learning experience through the awesome furniture we create.

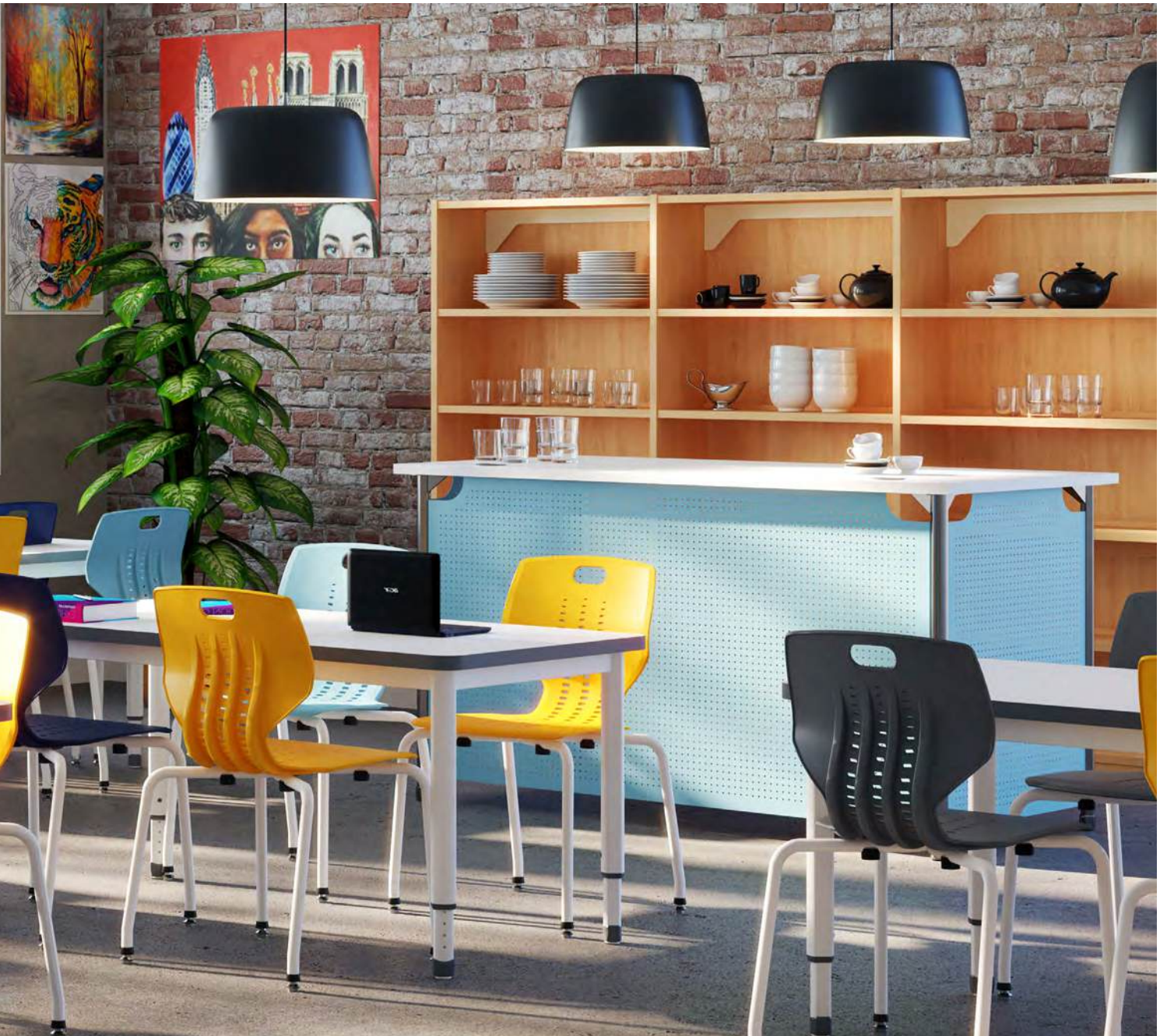

While we can furnish almost every square foot of interior space in most schools, we focus on 4 main areas:

Classroom | Makerspace | Library | Lounge

Each piece & every line is meticulously designed & engineered to work cohesively with the curriculum & in concert with the space. Classroom design shouldn't be an afterthought - let's make it a priority in every school.

PARAGON PRODUCT HIGHLIGHTS



SURFACE/EDGE

HIGH-PRESSURE LAMINATE

- Scratch, wear, heat, & moisture resistant.
- Non-porous surface withstands frequent cleaning & disinfectant protocols.

HIGH-DENSITY FIBERBOARD

- 100% post-consumer super-compressed wood composite with moisture resistant phenolic backing.

EDGE BANDING

- 3mm impermeable, flexible PVC applied with aircraft-grade EVA hot-melt adhesive to achieve tightest possible seal between surface & edge.



LEGS/FRAME

PARATUBE

- Proprietary flattened-oval steel tube that provides the most rigid structure for legs & frames.

8-POINT BEZEL SLEEVE

- Patented 8-point bezel sleeve provides a system to easily adjust leg height while increasing the strength of the connections.
- Polypropylene design adds accent color to the leg for functional, aesthetic appeal.



CHAIR SHELLS

READY CHAIR

- Gas-assist polypropylene shell creates a flexible back that allows for 18° of controlled flex.
- Sleek chamfered edge increases leg comfort & reduces strain.

EMOJI CHAIR

- 3 distinct shell designs highlight Sensory Ergonomics for each age range.
- Hole patterns on each chair creates proper air flow & narrow mid-section allows for 4-way sitting.



TABLE / DESK CONNECTIONS

STEEL THREADED INSERTS

- All table/desk legs connect to the surface using 6 steel threaded inserts.
- Greatly increases the durability of the connections & simplifies assembly.

STEEL GUSSET BRACE

- Full gusset brace creates superior structural integrity compared to wire braces & increases overall stability of the table/desk.



SHELVING

INFORMATION COMMONS

- IC Shelving has steel Paratube outer frame creating a solid, rigid structure that can withstand significant book weight.
- Decorative side panels are available in multiple materials & colors to add aesthetic appeal.

INFINITY

- Fiberboard shelving is reinforced with steel brackets at each connection point.
- Classic appearance complements traditional & modern library designs.



SOFT SEATING

MOTIV

- Full wood inner-frame with reinforced steel base for increased durability.
- High-density foam cushions with hundreds of choices of durable textiles in a wide range of colors & patterns.

BLENDER

- 95lb ILD high-density foam core with 3/4" plywood base & nylon glides.
- Double-stitched upholstery available in a huge array of durable colors & patterns.

TABLE OF CONTENTS

DESK & TABLES

A&D® ADJUSTABLE HEIGHT STUDENT DESKS	10
A&D® CROSSFIT STUDENT DESKS.....	23
A&D® CROSSFIT FLIP TOP STUDENT DESKS	29
A&D® ACTIVITY TABLES.....	35
MAKER® INVENT™ SERIES TABLES.....	43
ALL-WELDED TABLES.....	52
CHARGEBAR TABLES.....	60
TRAIN-IT TABLE	67
COMPUTE-IT TABLE.....	73
READ-IT TABLES	79
A&D® TEACHER DESK	86
TEACH-IT & RETURN-IT.....	92
A&D CROSSFIT TEACHER LECTERN & DESK.....	100

CHAIRS & SEATING

EMOJI™ SEATING.....	114
READY® CHAIRS & STOOLS.....	120
OINGO ADJUSTABLE PIVOT STOOL	126
BLENDER® FOAM SOFT SEATING	131

MOTIV® SEATING & TABLES

MOTIV® SOFT SEATING	138
MOTIV™ OCCASIONAL TABLES	151

STORAGE & SHELVING

A&D® CROSSFIT MOBILE STORAGE.....	158
FILE-IT MOBILE FILING CABINET	165
A&D® CROSSFIT SWEEP & DASH SHELVING	168
INFORMATION COMMONS SHELVING	173
INFORMATION COMMONS MOBILE SHELVING	187
INFORMATION COMMONS MOBILE CART	194
MOBILE CLASSROOM STORAGE	201
INFORMATION COMMONS CIRCULATION DESK....	204
INFINITY LIBRARY SHELVING	213
INFINITY CIRCULATION DESK.....	221

MARKERBOARDS

MAKER™ IDEA BOARD	227
-------------------------	-----





DESKS & TABLES



A&D® ADJUSTABLE HEIGHT STUDENT DESKS

Available in 10 different top shapes & multiple sizes, the A&D Adjustable Height Student Desk provides ideal solutions for flexible classroom configurations.



HOW TO SPECIFY

FRAME

Set of single-post flattened-oval Paratube 16-gauge steel adjustable legs. Legs adjust using patented polypropylene 8-point bezel insert system & reinforced set screw for ease of adjustment & increased stability. 11-gauge steel leg plate with 16-gauge steel gusset is attached to surface with (8) each per leg 10-32 diameter-thread pitch x $\frac{3}{4}$ " long machine screw with captured flat washer & split ring lock washer.

SURFACE/EDGE

1 $\frac{1}{4}$ " High Density Fiberboard core with High Pressure Laminate finish & machine applied edge-banding. Underneath surface has weather-resistant phenolic resin paper seal & 6 threaded metal inserts per leg (24 total) for added durability.

GLIDES/CASTERS

Threaded-steel extended post, steel outer housing, nylon-base, adjustable stability glides standard. Caster options include MOVE-IT, A&D MOVE-IT, & A&D DUALIE. All casters have locking option for stability or mobility as needed.

BACKPACK HOOK

All A&D Student Desks include a backpack hook to match the color specified for the edgebanding.

CERTIFICATIONS

- ANSI/BIFMA X5.5 Safety & performance standards for desk products.
- MAS certified green.
- LEED for Schools CHPS EQ 2.3.5 Credit.

STORAGE OPTIONS

A&D® BOOKBOX

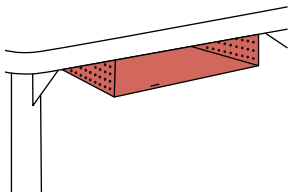

A&D® WIRE BOOKBOX

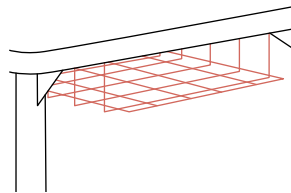

RAILS & TOTES

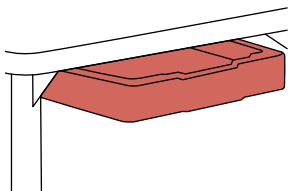

CASTER OPTIONS

A&D® MOVE-IT

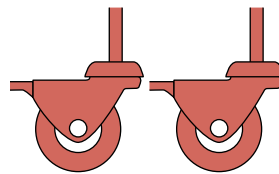

Adds 2" to overall height

A&D® DUALIE

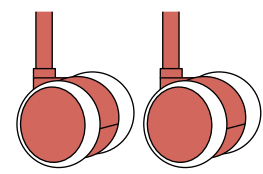

Adds 1.5" to overall height

MOVE-IT

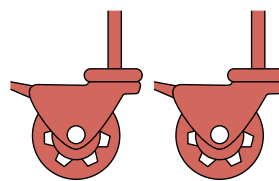

Adds 3" to overall height

STUDENT DESK CONFIGURATIONS

KOI



TRAPEZOID



TESLA



STEALTH



 PACMAN



 WEDGE



 POINT

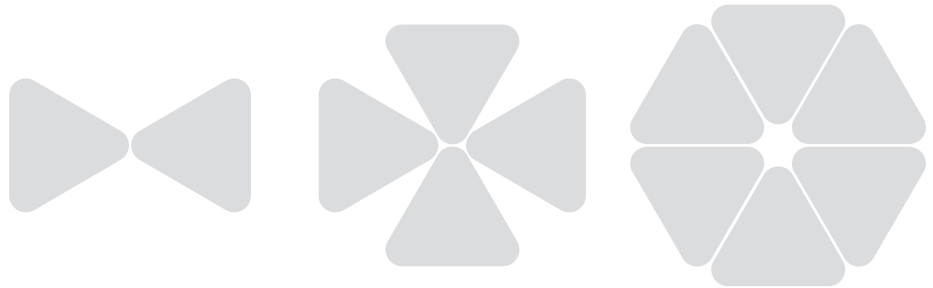

 SAPPHIRE



CONFIGURING A MODEL NUMBER

Refer to the Model Numbers & Product Specs section for a list of all family part model numbers in this product line. Use the chart below as a reference for how to properly specify this product.

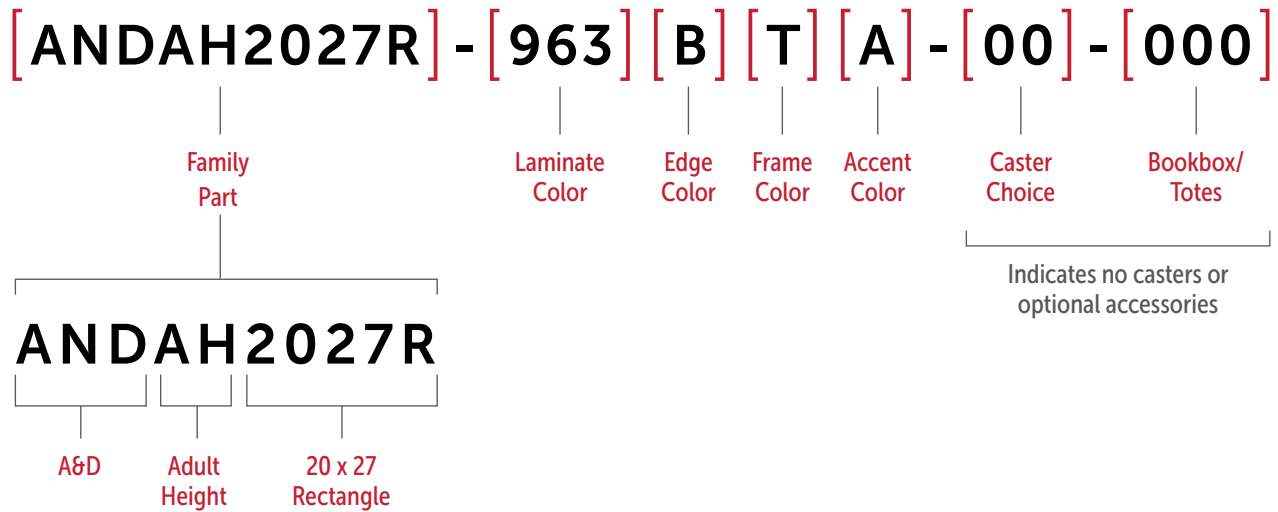

COLOR & FINISH OPTIONS





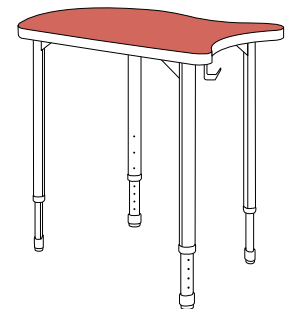







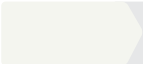

STEP 1 LAMINATE

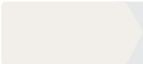
Use the number next to the laminate name as the key code for **STEP 1**

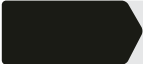

[**FAMILY PART**] - [**WORK SURFACE**]

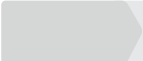
SOLID LAMINATE

 PARAGON RED (910)	 EARTH (185)	 FROST (918)	 CITADEL (303)
 MARS (743)	 STORM (770)	 NEUTRAL WHITE (123)	 NORTH SEA GRAY (535)
 CLEMENTINE (852)	 BLACK (900)	 FASHION GRAY (366)	 PLUM (736)
 ISLAND (229)	 COWBOY BLUE (976)	 FOLKSTONE (902)	 ORANGE GROVE (233)

WHITEBOARD LAMINATE



WOOD GRAIN LAMINATE

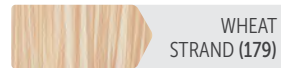
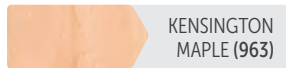
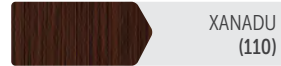

PATTERN LAMINATE



NEW COLORS

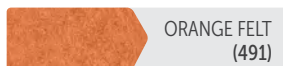
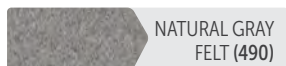
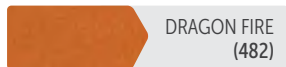







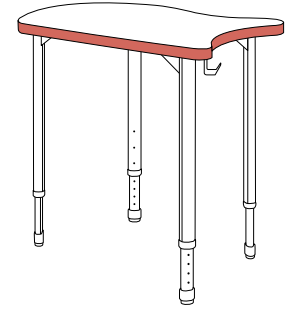







STEP 2 EDGE

Use the letter next to the color name as the key code for **STEP 2**

[FAMILY PART] - [WORK SURFACE] [EDGE COLOR]

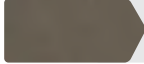

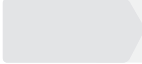

 FIRE TRUCK RED (A)	 VANILLA BLUE (E)	 PURPLE (P)	 BLUESCAPE (U)
 BLACK (B)	 GRASS GREEN (I)	 GREEN BEAN (Q)	 ORANGESICLE (X)
 MOD NAVY (C)	 GRAPHITE (M)	 GRAPLE (R)	 LELLO (Y)
 COFFEE (D)	 COOL GRAY (O)	 TANG (S)	 WISDOM (Z)

STEP 3 FRAME

Use the letter next to the color name as the key code for **STEP 3**

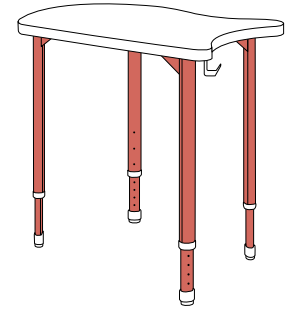
[FAMILY PART] - [WORK SURFACE] [EDGE COLOR] [FRAME COLOR]



 BLACK (B)	 TITANIUM (T)	 WISDOM (Z)
 FLANNEL (F)	 COOL GRAY (O)	

STEP 4 PLASTIC ACCENTS

Use the letter next to the color name as the key code for **STEP 4**

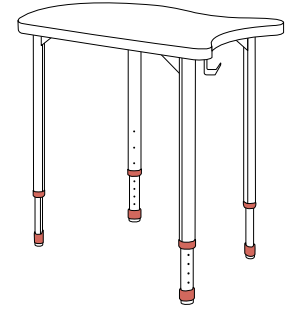

[FAMILY PART] - [WORK SURFACE] [EDGE COLOR] [FRAME COLOR] [PLASTIC ACCENT]

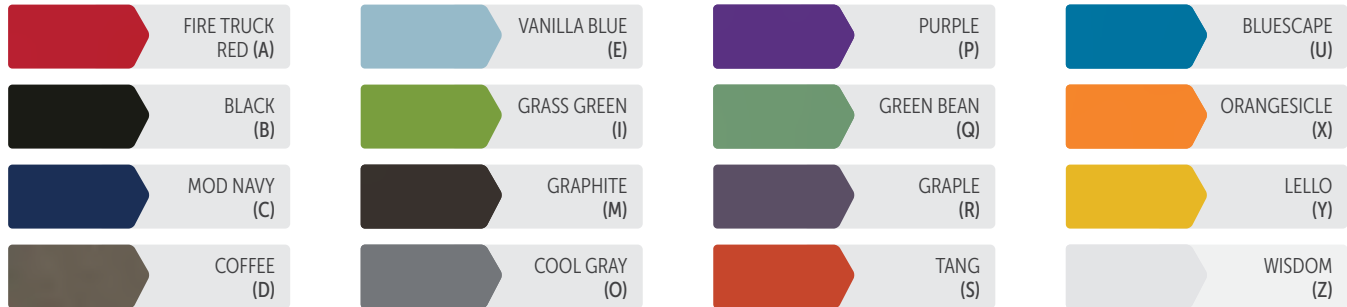

STEP 5 CASTER CHOICE (OPTIONAL)

Choose your caster type. Refer to the Caster Type key to locate the key code for your desired caster & quantity.

[FAMILY PART] - [WORK SURFACE] [EDGE COLOR] [FRAME COLOR] [PLASTIC ACCENT] - [CASTER CHOICE]

Caster Type Key: The key codes for the caster choices consist of two characters. The first character indicates the type of caster while the second character indicates the number of casters desired.

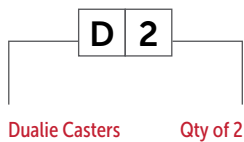

Caster Type Key

Caster	Key Code
AND-DUALIEX2	-D2
AND-DUALIEX3	-D3
AND-DUALIEX4	-D4
AND-MOVE-ITX2	-A2
AND-MOVE-ITX3	-A3
AND-MOVE-ITX4	-A4
MOVE-ITX2	-M2
MOVE-ITX3	-M3
MOVE-ITX4	-M4
NO CASTERS	-00

STEP 6 BOOKBOX / TOTE KEY

(OPTIONAL)

Choose your Bookbox or Totes. Refer to the Bookbox/Tote key to locate the key code for your desired bookbox type & color. In this example, we selected "no Bookbox or Totes" (key code 000).

[FAMILY PART] - [WORK SURFACE] [EDGE COLOR] [FRAME COLOR] [PLASTIC ACCENT] - [CASTER CHOICE] - [BOOKBOX / TOTES]

Metal Color Key: Single letters that are used to describe the color of metal items that are painted in house.

Bookbox/Tote Key

Metal Code	4" Metal Key Code	4" Wire Key Code
Fire Truck Red	-M4A	-W4A
Black	-M4B	-W4B
Mod Navy	-M4C	-W4C
Coffee	-M4D	-W4D
Vanilla Blue	-M4E	-W4E
Flannel	-M4F	-W4F
Grass Green	-M4I	-W4I
Graphite	-M4M	-W4M
Cool Gray	-M4O	-W4O
Purple	-M4P	-W4P
Green Bean	-M4Q	-W4Q
Graple	-M4R	-W4R
Tang	-M4S	-W4S
Titanium	-M4T	-W4T
Bluescape	-M4U	-W4U
Orangesicle	-M4X	-W4X
Lello	-M4Y	-W4Y
Wisdom	-M4Z	-W4Z

A&D® BOOKBOX

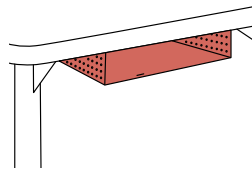

A&D® WIRE BOOKBOX

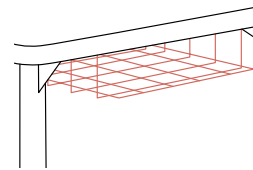

RAILS & TOTES

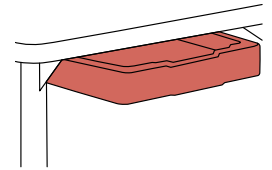

Bookbox/Tote Key: We offer two types of bookboxes that can be painted in any of our standard paint colors (see Metal Color Key). These bookboxes can either be Metal bookboxes or Wire bookboxes. Clear totes can be selected instead of bookboxes. They are available in 14" or 17" lengths.

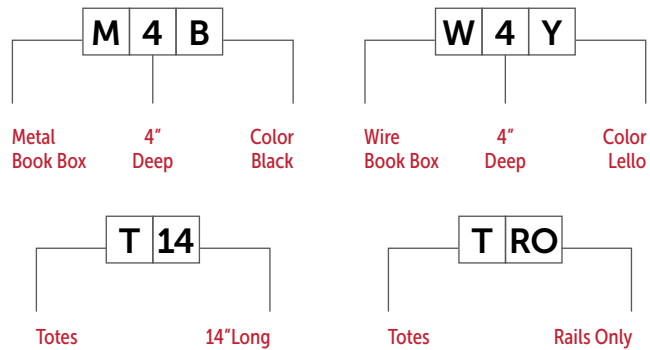

Totes Choices

Rails Only	14" Totes	17" Totes	No Bookboxes or Totes
-TRO	-T14	-T17	-000

MODEL NUMBERS & PRODUCT SPECS

A&D® RECTANGLE SURFACE ADJUSTABLE HEIGHT STUDENT DESK

Model #	Width (in)	Depth (in)	Height (in)	Weight (lbs)	Dist. Between Legs (in)	Freight Class (Qty 1)
ANDAH2027R	27	20	24 - 34	35	20.5	85
ANDEH2027R	27	20	16 - 24	35	20.5	85
ANDGH2027R	27	20	24 - 38	35	20.5	85
ANDAH2427R	27	24	24 - 34	39	20.5	85
ANDEH2427R	27	24	16 - 24	39	20.5	85
ANDGH2427R	27	24	24 - 38	39	20.5	85
ANDAH2030R	30	20	24 - 34	37	22	85
ANDEH2030R	30	20	16 - 24	37	22	85
ANDGH2030R	30	20	24 - 38	37	22	85
ANDAH2430R	30	24	24 - 34	41	22	85
ANDEH2430R	30	24	16 - 24	41	22	85
ANDGH2430R	30	24	24 - 38	41	22	85
ANDAH2048R	48	20	24 - 34	50	39.5	85
ANDEH2048R	48	20	24 - 34	50	39.5	85
ANDGH2048R	48	20	24 - 38	50	39.5	85
ANDAH2448R	48	24	24 - 34	56	39.5	85
ANDEH2448R	48	24	16 - 24	56	39.5	85
ANDGH2448R	48	24	24 - 38	56	39.5	85
ANDAH2054R	54	20	16 - 24	54	45.5	85
ANDEH2054R	54	20	16 - 24	54	45.5	85
ANDGH2054R	54	20	24 - 38	54	45.5	85
ANDAH2454R	54	24	24 - 34	61	45.5	85
ANDEH2454R	54	24	24 - 34	61	45.5	85
ANDGH2454R	54	24	24 - 38	61	45.5	85
ANDAH2060R	60	20	24 - 34	58	51.5	85
ANDEH2060R	60	20	16 - 24	58	51.5	85
ANDGH2060R	60	20	24 - 38	58	51.5	85
ANDAH2460R	60	24	24 - 34	66	51.5	85
ANDEH2460R	60	24	16 - 24	66	51.5	85
ANDGH2460R	60	24	24 - 38	66	51.5	85

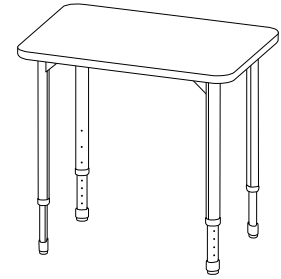

A&D® TRAPEZOID ADJUSTABLE HEIGHT STUDENT DESK

Model #	Width (in)	Depth (in)	Height (in)	Weight (lbs)	Dist. Between Legs (in)	Freight Class (Qty 1)
ANDAHTRAP	35	23	24 - 34	43	27	85
ANDEHTRAP	35	23	16 - 24	43	27	85
ANDGHTRAP	35	23	24 - 38	43	27	85

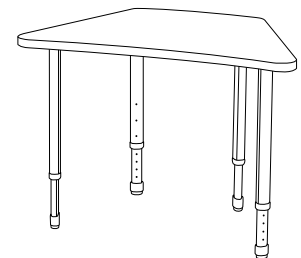



A&D® KOI ADJUSTABLE HEIGHT STUDENT DESK

Model #	Width (in)	Depth (in)	Height (in)	Weight (lbs)	Dist. Between Legs (in)	Freight Class (Qty 1)
ANDAH2030K	30	20	24 - 34	37	21.5	85
ANDEH2030K	30	20	16 - 24	37	21.5	85
ANDGH2030K	30	20	24 - 38	37	21.5	85
ANDAH2233K	33	22	24 - 34	41.5	22.5	85
ANDEH2233K	33	22	16 - 24	41.5	22.5	85
ANDGH2233K	33	22	24 - 38	41.5	22.5	85
ANDAH2436K	36	24	24 - 34	46	25.5	85
ANDEH2436K	36	24	16 - 24	46	25.5	85
ANDGH2436K	36	24	24 - 38	46	25.5	85

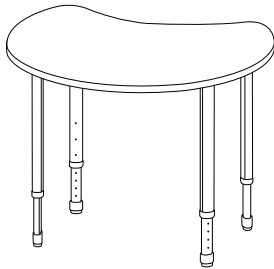

A&D® PACMAN ADJUSTABLE HEIGHT STUDENT DESK

Model #	Width (in)	Depth (in)	Height (in)	Weight (lbs)	Dist. Between Legs (in)	Freight Class (Qty 1)
ANDAH PAC	42	35	24 - 34	67.5	27	85
ANDEH PAC	42	35	16 - 24	67.5	27	85
ANDGH PAC	42	35	24 - 38	67.5	27	85

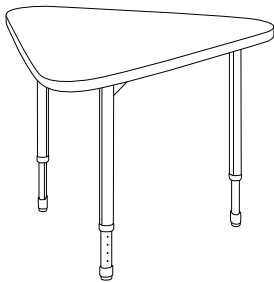

A&D® POINT ADJUSTABLE HEIGHT STUDENT DESK

Model #	Width (in)	Depth (in)	Height (in)	Weight (lbs)	Dist. Between Legs (in)	Freight Class (Qty 1)
ANDAH POINT	34	30.5	24 - 34	46.5	24.5	85
ANDEH POINT	34	30.5	16 - 24	46.5	24.5	85
ANDGH POINT	34	30.5	24 - 38	46.5	24.5	85

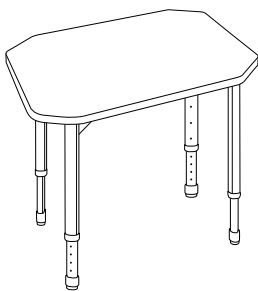

A&D® SAPPHIRE ADJUSTABLE HEIGHT STUDENT DESK

Model #	Width (in)	Depth (in)	Height (in)	Weight (lbs)	Dist. Between Legs (in)	Freight Class (Qty 1)
ANDAH SAPP	47	35	24 - 34	71	21	85
ANDEH SAPP	47	35	16 - 24	71	21	85
ANDGH SAPP	47	35	24 - 38	71	21	85

A&D® STEALTH ADJUSTABLE HEIGHT STUDENT DESK

Model #	Width (in)	Depth (in)	Height (in)	Weight (lbs)	Dist. Between Legs (in)	Freight Class (Qty 1)
ANDAHSTEAL	36	28	24 - 34	38.5	25.5	85
ANDEHSTEAL	36	28	16 - 24	38.5	25.5	85
ANDGHSTEAL	36	28	24 - 38	38.5	25.5	85

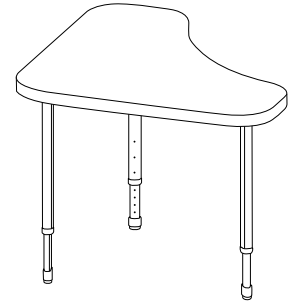

A&D® TESLA ADJUSTABLE HEIGHT STUDENT DESK

Model #	Width (in)	Depth (in)	Height (in)	Weight (lbs)	Dist. Between Legs (in)	Freight Class (Qty 1)
ANDAHTESLAL	32	27	24 - 34	45.5	22	85
ANDEHTESLAL	32	27	16 - 24	45.5	22	85
ANDGHTESLAL	32	27	24 - 38	45.5	22	85
ANDAHTESLAR	32	27	24 - 34	45.5	22	85
ANDEHTESLAR	32	27	16 - 24	45.5	22	85
ANDGHTESLAR	32	27	24 - 38	45.5	22	85

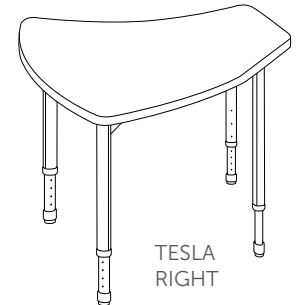
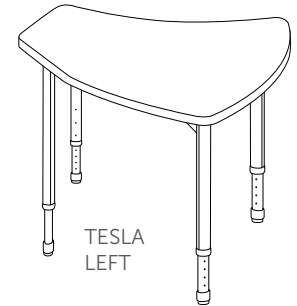

L = Left, R= Right at the end of the model #

A&D® WEDGE ADJUSTABLE HEIGHT STUDENT DESK

Model #	Width (in)	Depth (in)	Height (in)	Weight (lbs)	Dist. Between Legs (in)	Freight Class (Qty 1)
ANDAHWEDGE	50	35	24 - 34	77	27	85
ANDEHWEDGE	50	35	16 - 24	77	27	85
ANDGHWEDGE	50	35	24 - 38	77	27	85



MODEL #	BETWEEN LEGS	AND-BOOKBOX4	AND-WIRE-BOOKBOX4 (W4)	AND-RAILS (TRO)	AND-TOTE-RAILS17 (T17)	AND-TOTE-RAILS14 (T14)	AND-MOVE-ITX2 (A2)	AND-MOVE-ITX3 (A3)	AND-MOVE-ITX4 (A4)	AND-DUALLEX2 (D2)	AND-DUALLEX3 (D3)	AND-DUALLEX4 (D4)	MOVE-ITX2 (M2)	MOVE-ITX3 (M3)	MOVE-ITX4 (M4)
		(M4)	(W4)	(TRO)	(T17)	(T14)	(A2)	(A3)	(A4)	(D2)	(D3)	(D4)	(M2)	(M3)	(M4)
ANDAH2027R ANDEH2027R ANDGH2027R	20.5	X	X	X		X	X		X	X		X	X		X
ANDAH2427R ANDEH2427R ANDGH2427R	20.5	X	X	X	X	X	X		X	X		X	X		X
ANDAH2030R ANDEH2030R ANDGH2030R	22	X	X	X	X	X	X		X	X		X	X		X
ANDAH2430R ANDEH2430R ANDGH2430R	22	X	X	X	X	X	X		X	X		X	X		X
ANDAH2048R ANDEH2048R ANDGH2048R	39.5						X		X	X		X	X		X
ANDAH2448R ANDEH2448R ANDGH2448R	39.5	X	X	X	X	X	X		X	X		X	X		X
ANDAH2054R ANDEH2054R ANDGH2054R	45.5					X	X		X	X		X	X		X
ANDAH2454R ANDEH2454R ANDGH2454R	45.5	X	X	X	X	X	X		X	X		X	X		X
ANDAH2060R ANDEH2060R ANDGH2060R	51.5					X	X		X	X		X	X		X
ANDAH2460R ANDEH2460R ANDGH2460R	51.5	X	X	X	X	X	X		X	X		X	X		X
ANDAH2030K ANDEH2030K ANDGH2030K	21.5	X				X	X		X	X		X	X		X
ANDAH2233K ANDEH2233K ANDGH2233K	22.5	X	X	X		X	X		X	X		X	X		X
ANDAH2436K ANDEH2436K ANDGH2436K	25.5	X	X	X	X	X	X		X	X		X	X		X
ANDAH PAC ANDEH PAC ANDGH PAC	17	X	X	X	X	X	X		X	X		X	X		X
ANDAH POINT ANDEH POINT ANDGH POINT	24.5	X	X	X	X	X		X			X			X	
ANDAH SAPP ANDEH SAPP ANDGH SAPP	21	X	X	X	X	X	X		X	X		X	X		X
ANDAH STEAL ANDEH STEAL ANDGH STEAL	25.5	X						X			X			X	
ANDAH TESLAL ANDEH TESLAL ANDGH TESLAL	22	X	X	X		X	X		X	X		X	X		X
ANDAH TESLAR ANDEH TESLAR ANDGH TESLAR	22	X	X	X		X	X		X	X		X	X		X
ANDAH TRAP ANDEH TRAP ANDGH TRAP	27	X					X		X	X		X	X		X
ANDAH WEDGE ANDEH WEDGE ANDGH WEDGE	27	X	X	X		X	X		X	X		X	X		X



A&D® CROSSFIT STUDENT DESKS

The A&D® Crossfit Student Desks are designed to support today's educational environments. Strong & durable, the T-leg desk is ideal for multiple learning solutions. Desks come either with a fixed leg or height adjustable leg in various non-flip work surface shapes & size options. Desks come standard with casters.

THE DIFFERENCE

There's an innate difference when you specify Paragon Furniture. We're dedicated to designing safe & eco-friendly furniture that lasts. Our products are tested to meet & exceed ANSI/BIFMA certifications, we are committed to complying with MAS Certified Green criteria & our products are assembled in the U.S.A.

WORK SURFACE

Top constructed of 3/4" thick 45lb density particleboard core with high-pressure laminate finish & 3mm machine-applied PVC edge banding.

CASTERS

Four locking Dualie Casters included on all Crossfit Student Desks.

FRAME

Paratube flattened-oval adjustable-height cold-rolled steel tube, with 14-gauge uppers & 16-gauge lowers that adjust from 25"-36" using 8 contact point plastic-molded bezels & reinforced set screws.

FEATURES

SURFACE/EDGE

3/4" HPL with edgeband.

COLOR OPTIONS

Five frame paint options with your choice of standard laminate colors for your top surface & multiple accents to choose from.

MINIMAL ASSEMBLY REQUIRED

FRAME

Flattened oval set of two T-legs using oval tube matching both the existing all terrain legs & the A&D tubing on the cantilever frame. Height adjustment is achieved with 8 contact points on plastic-molded bezels, & the contoured plastic molded end cap is held in place with the insertion of the caster.

BACKPACK HOOK

All desks include a hook to hang a backpack.



CONFIGURING A MODEL NUMBER

Refer to the Model Numbers & Product Specs section for a list of all family part model numbers in this product line. Use the chart below as a reference for how to properly specify this product.

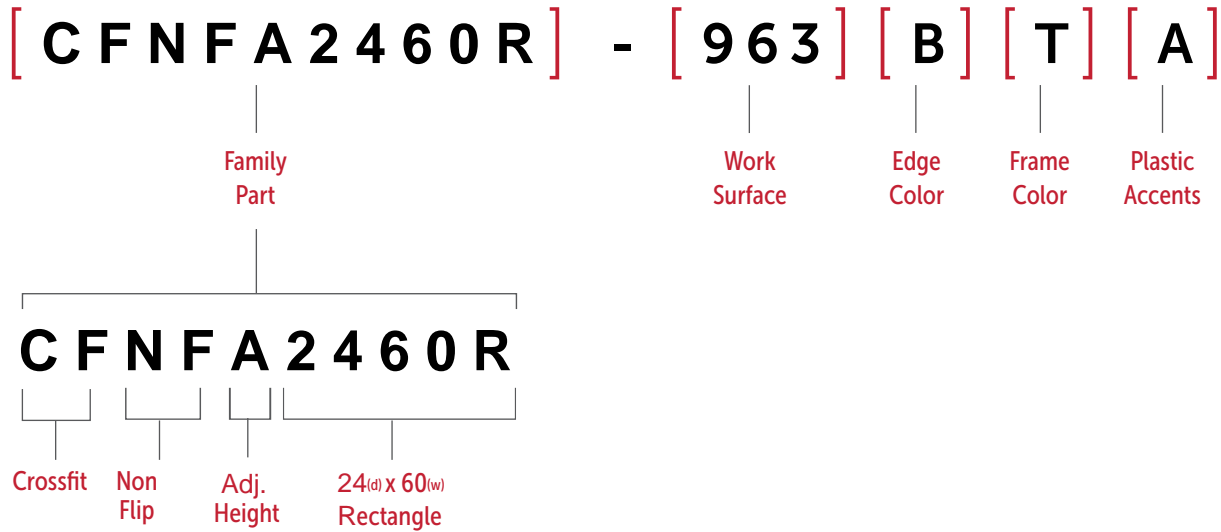

COLOR & FINISH OPTIONS





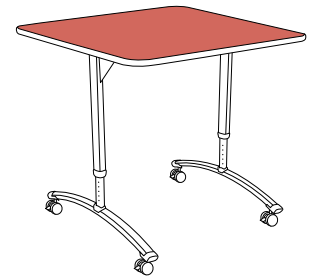







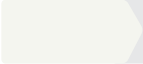

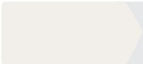

STEP 1 WORK SURFACE

Use the number next to the laminate name as the key code for **STEP 1**



[**FAMILY PART**] - [**WORK SURFACE**]

SOLID LAMINATE

 PARAGON RED (910)	 EARTH (185)	 FROST (918)	 CITADEL (303)
 MARS (743)	 STORM (770)	 NEUTRAL WHITE (123)	 NORTH SEA GRAY (535)
 CLEMENTINE (852)	 BLACK (900)	 FASHION GRAY (366)	 PLUM (736)
 ISLAND (229)	 COWBOY BLUE (976)	 FOLKSTONE (902)	 ORANGE GROVE (233)

WHITEBOARD LAMINATE



WOOD GRAIN LAMINATE

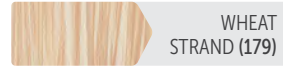
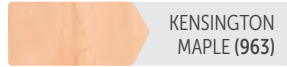

PATTERN LAMINATE

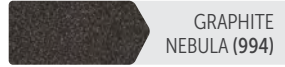

NEW COLORS

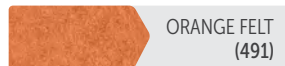
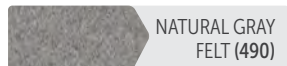
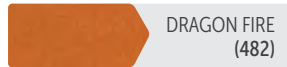

STEP 2 EDGE

Use the letter next to the color name as the key code for **STEP 2**

[FAMILY PART] - [WORK SURFACE] [EDGE COLOR]

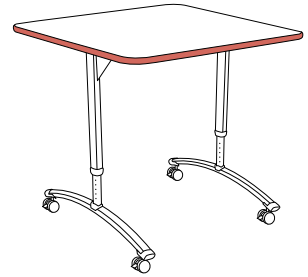
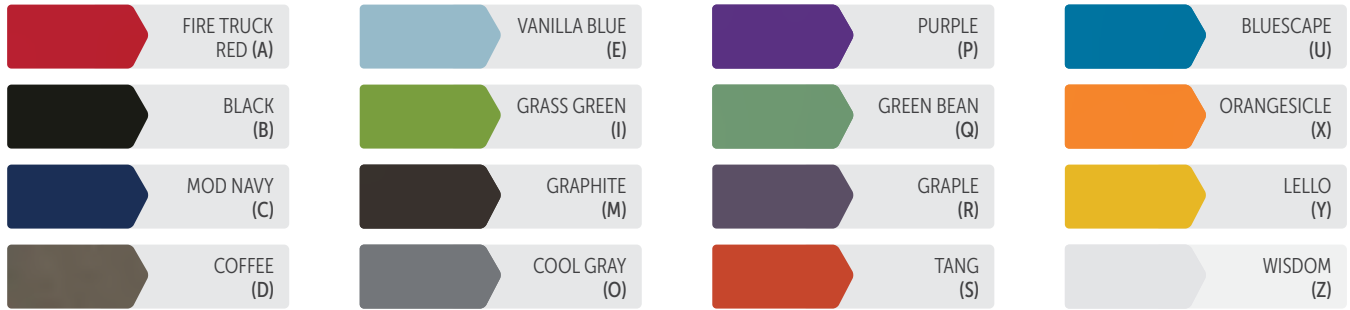

STEP 3 FRAME

Choose your frame color. Refer to the Frame Color Key to locate the key code for **STEP 3**

[FAMILY PART] - [WORK SURFACE] [EDGE COLOR] [FRAME COLOR]



STEP 4 PLASTIC ACCENTS

Use the letter next to the color name as the key code for **STEP 4**

[FAMILY PART] - [WORK SURFACE] [EDGE COLOR] [FRAME COLOR] [PLASTIC ACCENT]

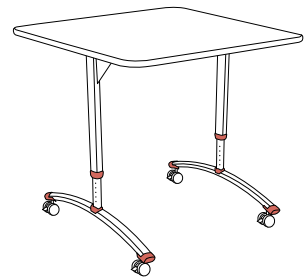
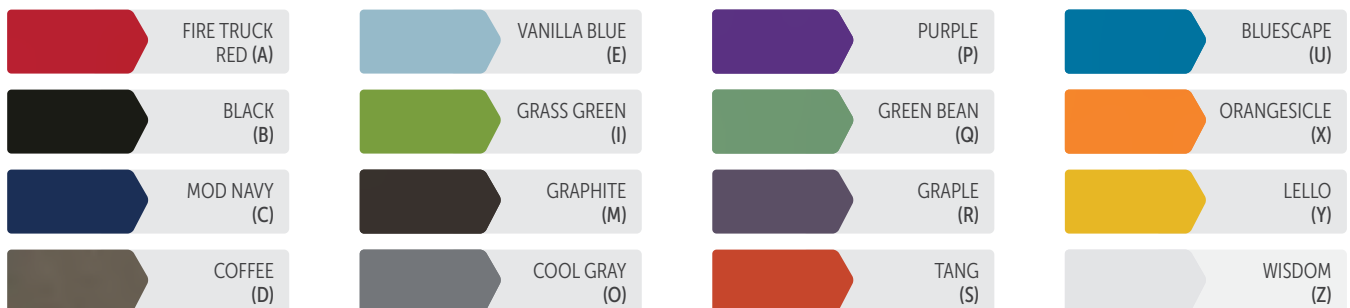

MODEL NUMBERS & PRODUCT SPECS

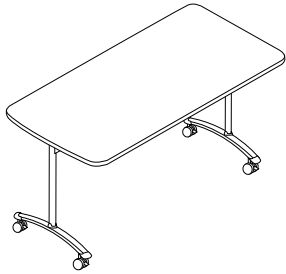

NON-FLIP TOP STUDENT DESK WITH FIXED HEIGHT LEG

Model #	Work Surface	Width (in)	Depth (in)	Height (in)	Weight (lbs)	Dist. Between Legs (in)	Freight Class (Qty 1)
CFNFF302730R	Rectangle	27	30	30	40	22.5	125
CFNFF304830R	Rectangle	48	30	30	50	43.5	125
CFNFF305430R	Rectangle	54	30	30	55	49.5	125
CFNFF306030R	Rectangle	60	30	30	60	55.5	125



NON-FLIP TOP D-SHAPE STUDENT DESK WITH FIXED HEIGHT LEG

Model #	Work Surface	Width (in)	Depth (in)	Height (in)	Weight (lbs)	Dist. Between Legs (in)	Freight Class (Qty 1)
CFNFF306030D	D-Shape	60	30	30	60	42.5	125

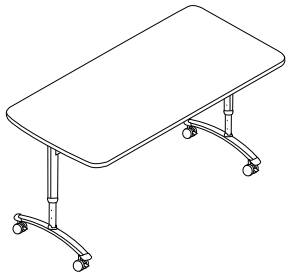

NON-FLIP TOP STUDENT DESK WITH ADJUSTABLE HEIGHT LEG

Model #	Work Surface	Width (in)	Depth (in)	Height (in)	Weight (lbs)	Dist. Between Legs (in)	Freight Class (Qty 1)
CFNFA2027R	Rectangle	27	20	25 - 36	35	22.5	125
CFNFA2048R	Rectangle	48	20	25 - 36	45	43.5	125
CFNFA2054R	Rectangle	54	20	25 - 36	50	49.5	125
CFNFA2060R	Rectangle	60	20	25 - 36	52	55.5	125
CFNFA2427R	Rectangle	27	24	25 - 36	35	22.5	125
CFNFA2448R	Rectangle	48	24	25 - 36	51	43.5	125
CFNFA2454R	Rectangle	54	24	25 - 36	56	49.5	125
CFNFA2460R	Rectangle	60	24	25 - 36	62	55.5	125



NON-FLIP TOP D-SHAPE STUDENT DESK WITH ADJUSTABLE HEIGHT LEG

Model #	Work Surface	Width (in)	Depth (in)	Height (in)	Weight (lbs)	Dist. Between Legs (in)	Freight Class (Qty 1)
CFNFA2448D	D-Shape	48	24	25 - 36	50	30.5	125



NON-FLIP TOP KOI STUDENT DESK WITH ADJUSTABLE HEIGHT LEG

Model #	Work Surface	Width (in)	Depth (in)	Height (in)	Weight (lbs)	Dist. Between Legs (in)	Freight Class (Qty 1)
CFNFA2436K	KOI	36	24	25 - 36	50	42.5	125



A&D® CROSSFIT FLIP TOP STUDENT DESKS

The A&D® Crossfit Flip Top Student Desks are designed & built for mobility & reconfiguration of a space. Learning can happen anywhere, Crossfit Flip Top Student Desks provide a flexible solution that is easily reconfigurable.

THE DIFFERENCE

There's an innate difference when you specify Paragon Furniture. We're dedicated to designing safe & ecofriendly furniture that lasts. Our products are tested to meet & exceed ANSI/BIFMA certifications, we are committed to complying with MAS Certified Green criteria & our products are 100% assembled in the U.S.A.

⬡ PATENTED KOI SHAPED WORK SURFACE

Patented KOI shaped top constructed of ¾" thick 45lb density particleboard core with high-pressure laminate finish & 3mm machine-applied PVC edge banding.

⬡ SAFETY

The double spring latch mechanisms work independently of each other, as well the vertical position safety latch ensures the desk only flips when needed.

⬡ FRAME

Paratube flattened-oval adjustable-height cold rolled steel tube, with 14-gauge uppers & 16-gauge lowers that adjust from 25"-36" using 8-contact point plastic-molded bezels & reinforced set screws.

⬡ CASTERS

Four locking Dualie casters included on all Crossfit Student Desks.

FEATURES

⬡ SURFACE / EDGE

¾" HPL with edgband.

⬡ COLOR OPTIONS

Five frame paint options with your choice of standard laminate colors for your top surface & a multiple accents to choose from.

⬡ MINIMAL ASSEMBLY REQUIRED

⬡ FRAME

Flattened oval set of two T-legs using oval tube matching both the existing all terrain legs & the A&D tubing on the cantilever frame. Height adjustment is achieved with 8 contact points on plastic-molded bezels, & the end cap is held in place with the insertion of the caster.

⬡ BACKPACK HOOK

All desks include a hook to hang a backpack.



CONFIGURING A MODEL NUMBER

Refer to the Model Numbers & Product Specs section for a list of all family part model numbers in this product line. Use the chart below as a reference for how to properly specify this product.

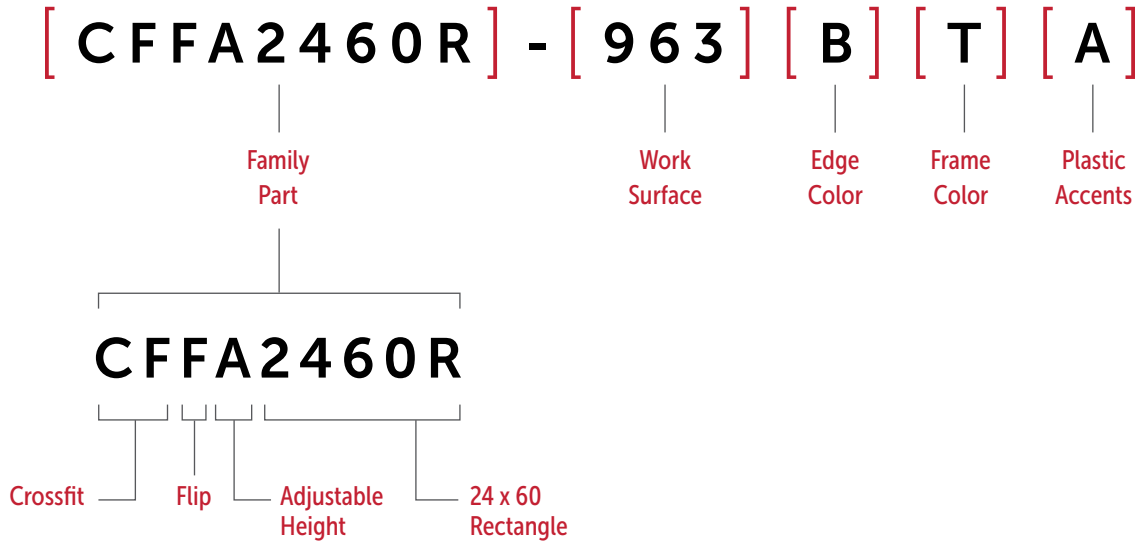

COLOR & FINISH OPTIONS













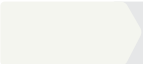

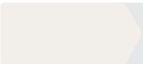

STEP 1 WORK SURFACE

Use the number next to the laminate name as the key code for **STEP 1**



[**FAMILY PART**] - [**WORK SURFACE**]

◻ SOLID LAMINATE

 PARAGON RED (910)	 EARTH (185)	 FROST (918)	 CITADEL (303)
 MARS (743)	 STORM (770)	 NEUTRAL WHITE (123)	 NORTH SEA GRAY (535)
 CLEMENTINE (852)	 BLACK (900)	 FASHION GRAY (366)	 PLUM (736)
 ISLAND (229)	 COWBOY BLUE (976)	 FOLKSTONE (902)	 ORANGE GROVE (233)

WHITEBOARD LAMINATE



WOOD GRAIN LAMINATE

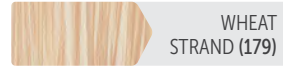
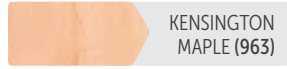

PATTERN LAMINATE

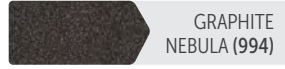

NEW COLORS

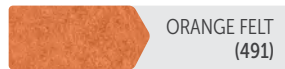
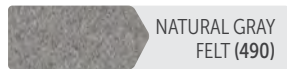

STEP 2 EDGE

Use the letter next to the color name as the key code for **STEP 2**

[FAMILY PART] - [WORK SURFACE] [EDGE COLOR]

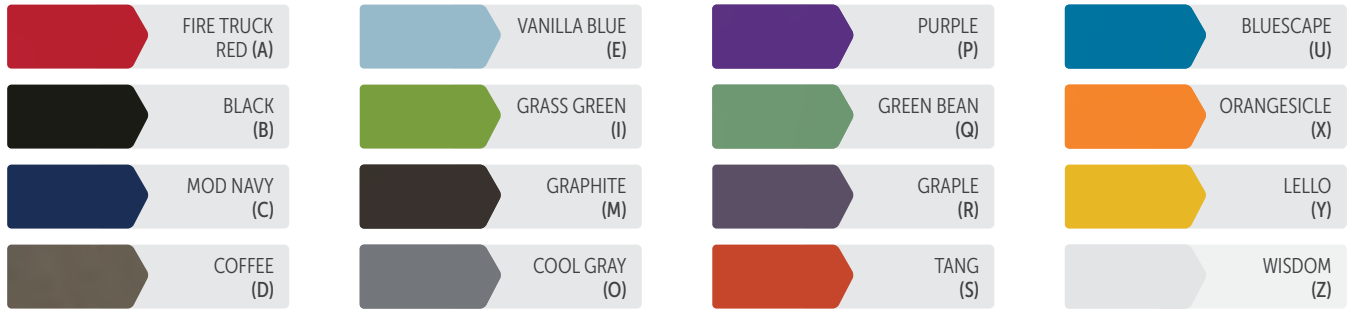

STEP 3 FRAME

Choose your frame color. Refer to the Frame Color Key to locate the key code for **STEP 3**

[FAMILY PART] - [WORK SURFACE] [EDGE COLOR] [FRAME COLOR]



STEP 4 PLASTIC ACCENTS

Use the letter next to the color name as the key code for **STEP 4**

[FAMILY PART] - [WORK SURFACE] [EDGE COLOR] [FRAME COLOR] [PLASTIC ACCENT]

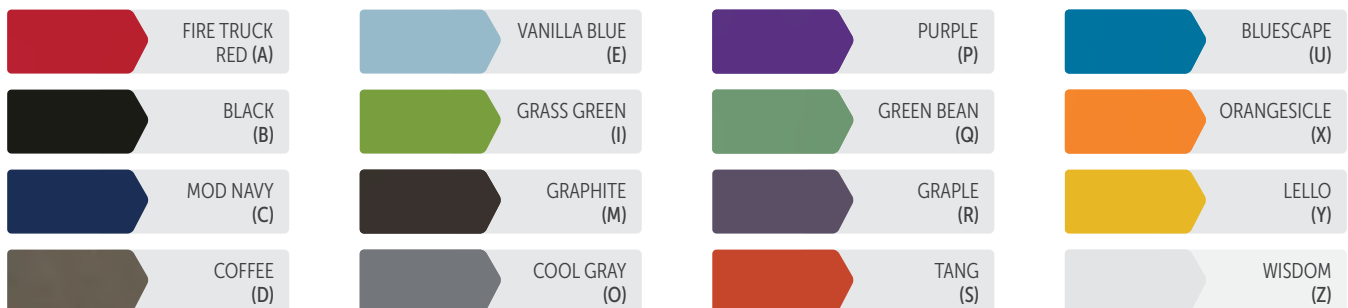

MODEL NUMBERS & PRODUCT SPECS

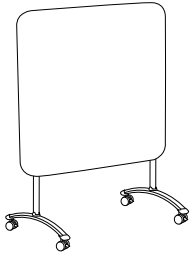

FLIP TOP RECTANGLE STUDENT DESK WITH FIXED HEIGHT LEGS

Model #	Work Surface	Width (in)	Depth (in)	Height (in)	Weight (lbs)	Dist. Between Legs (in)	Freight Class (Qty 1)
CFFF302730R	Rectangle	27	30	30	40	22.5	125
CFFF304830R	Rectangle	48	30	30	50	43.5	125
CFFF305430R	Rectangle	54	30	30	59	49.5	125
CFFF306030R	Rectangle	60	30	30	64	55.5	125

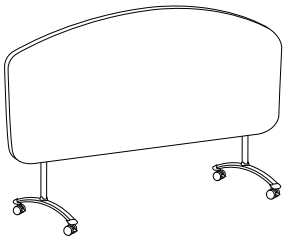

FLIP TOP D-SHAPE STUDENT DESK WITH FIXED HEIGHT LEGS

Model #	Work Surface	Width (in)	Depth (in)	Height (in)	Weight (lbs)	Dist. Between Legs (in)	Freight Class (Qty 1)
CFFF306030D	D-Shape	24	30	30	64	30.5	125

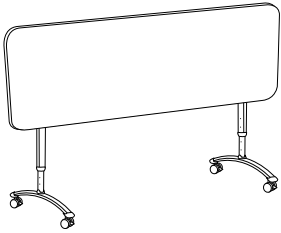

FLIP TOP RECTANGLE STUDENT DESK WITH ADJUSTABLE HEIGHT LEGS

Model #	Work Surface	Width (in)	Depth (in)	Height (in)	Weight (lbs)	Dist. Between Legs (in)	Freight Class (Qty 1)
CFFA2027R	Rectangle	27	20	25 - 36	30	22.5	125
CFFA2048R	Rectangle	48	20	25 - 36	40	43.5	125
CFFA2054R	Rectangle	54	20	25 - 36	45	49.5	125
CFFA2060R	Rectangle	60	20	25 - 36	50	55.5	125
CFFA2427R	Rectangle	27	24	25 - 36	35	22.5	125
CFFA2448R	Rectangle	48	24	25 - 36	45	43.5	125
CFFA2454R	Rectangle	54	24	25 - 36	50	49.5	125
CFFA2460R	Rectangle	60	24	25 - 36	60	55.5	125

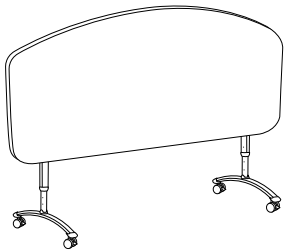

FLIP TOP D-SHAPE STUDENT DESK WITH ADJUSTABLE HEIGHT LEGS

Model #	Work Surface	Width (in)	Depth (in)	Height (in)	Weight (lbs)	Dist. Between Legs (in)	Freight Class (Qty 1)
CFFA2448D	D-Shape	48	24	25 - 36	55	30.5	125

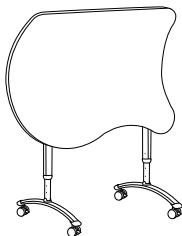

FLIP TOP KOI STUDENT DESK WITH ADJUSTABLE HEIGHT LEGS

Model #	Work Surface	Width (in)	Depth (in)	Height (in)	Weight (lbs)	Dist. Between Legs (in)	Freight Class (Qty 1)
CFFA2436K	KOI	36	24	25 - 36	46	31.5	125



A&D® ACTIVITY TABLES

Available in 7 different top shapes & multiple sizes, the A&D Activity Tables provide ideal solutions for flexible classroom configurations.



RECTANGLE
60" x 30"

TRAPEZOID
60" x 30"

PUZZLE
65" x 45"

FLOWER
60" x 60"

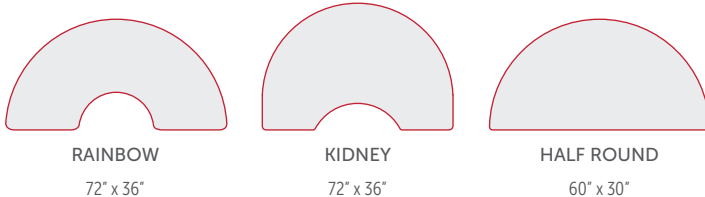

RAINBOW
72" x 36"

KIDNEY
72" x 36"

HALF ROUND
60" x 30"



Giraffe Ht.
24" - 38"
Standard Ht.
24" - 34"
Elementary Ht.
16" - 24"

HOW TO SPECIFY

A&D® Activity Tables create an ideal environment for small group activities. Bringing versatility to any space, this table is available as a rectangle, half round, trapazoid, flower, rainbow, kidney & puzzle shape. Available standard with glides or optional casters for additional mobility & greater flexibility in configurations. Push them together or mix & match to create the ideal set-up for collaboration.

FRAME

Set of four, single-post flattened-oval Paratube adjustable legs. Frame allows desk to adjust in height from 24"-34" on Standard Height, 16"-24" on Elementary Height, and 24"-38" on Giraffe Height. Legs adjust using patented polypropylene 8-point bezel insert system & reinforced set screw for ease of adjustment and increased stability.

SURFACE/EDGE

1 1/4" High Density Fiberboard core with High Pressure Laminate finish & machine applied edge-banding. Underneath surface has weather-resistant paper seal & 6 threaded metal inserts per leg (24) for added durability.

GLIDES/CASTERS

Threaded-steel extended post, steel outer housing, nylon-base, adjustable stability glides standard. Caster options include A&D® MOVE-IT & A&D® DUALIE which can be added to 4 legs, or 2 legs for wheelbarrow configuration. All casters have locking option for stability or mobility as needed.

CERTIFICATIONS

- ANSI/BIFMA X5.5 Safety & performance standards for desk products
- MAS certified green
- LEED for schools CHPS EQ 2.3.5 credit



Trapezoid



Half Round



Rectangle



Kidney



Rainbow



Flower



Puzzle

CONFIGURING A MODEL NUMBER

Refer to the Model Numbers & Product Specs section for a list of all family part model numbers in this product line. Use the chart below as a reference for how to properly specify this product.

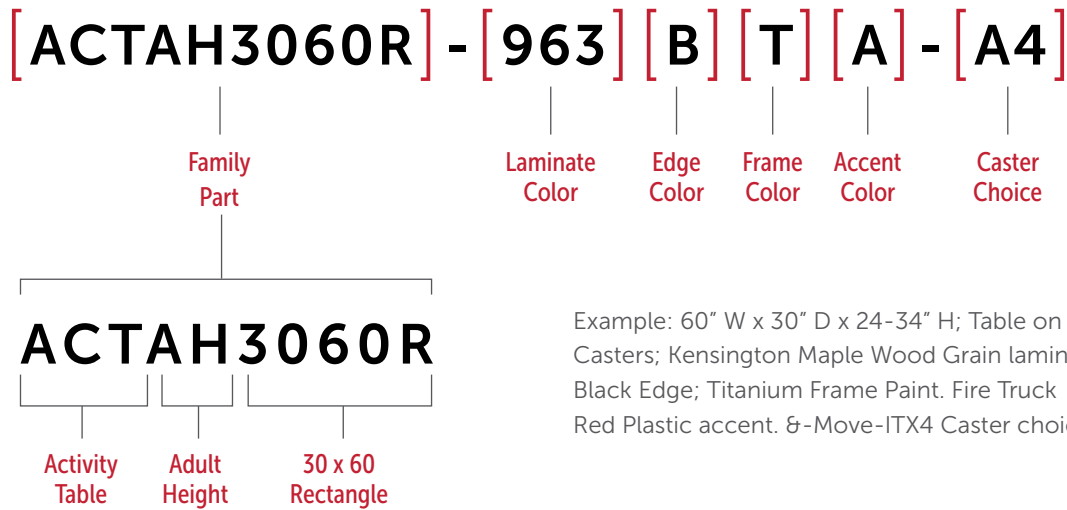

COLOR & FINISH OPTIONS

STEP 1 WORK SURFACE

Use the number next to the laminate name as the key code for **STEP 1**

[FAMILY PART] - [WORK SURFACE]

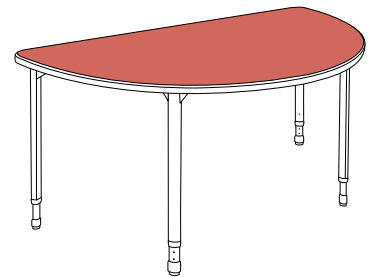

SOLID LAMINATE

PARAGON RED (910)	EARTH (185)	FROST (918)	CITADEL (303)
MARS (743)	STORM (770)	NEUTRAL WHITE (123)	NORTH SEA GRAY (535)
CLEMENTINE (852)	BLACK (900)	FASHION GRAY (366)	PLUM (736)
ISLAND (229)	COWBOY BLUE (976)	FOLKSTONE (902)	ORANGE GROVE (233)

WHITEBOARD LAMINATE



WOOD GRAIN LAMINATE

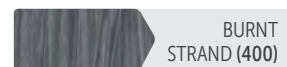
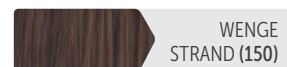

PATTERN LAMINATE



NEW COLORS

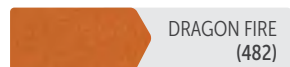

STEP 2 EDGE

Use the letter next to the color name as the key code for **STEP 2**

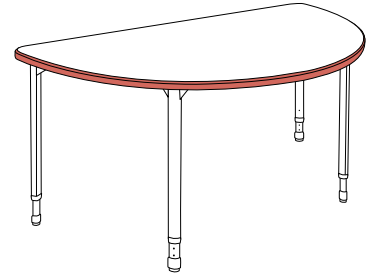

[FAMILY] - [WORK] [EDGE]
[PART] - [SURFACE] [COLOR]

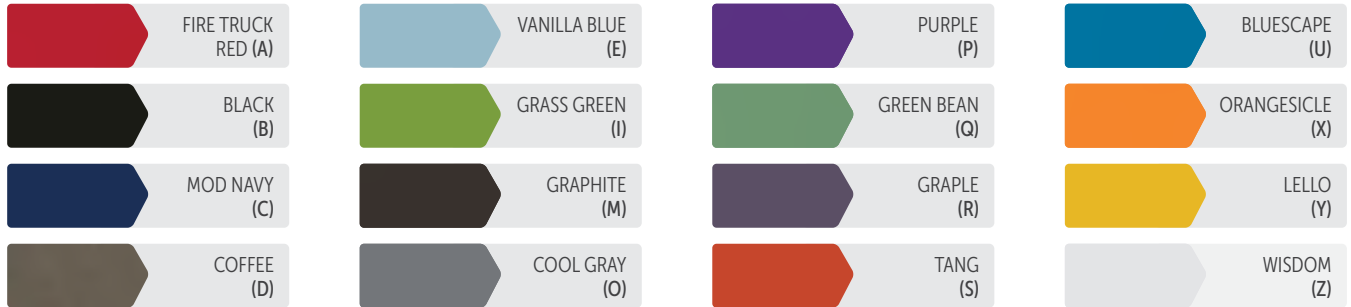

STEP 3 FRAME

Use the letter next to the color name as the key code for **STEP 3**

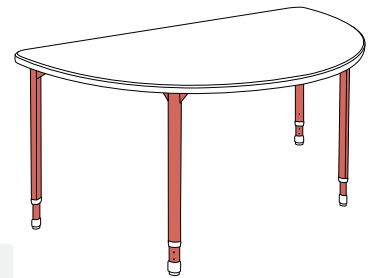

[FAMILY] - [WORK] [EDGE] [FRAME]
[PART] - [SURFACE] [COLOR] [COLOR]



STEP 4 PLASTIC ACCENTS

Use the letter next to the color name as the key code for **STEP 4**

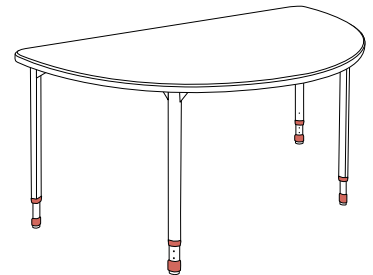

[FAMILY] - [WORK] [EDGE] [FRAME] [PLASTIC]
[PART] - [SURFACE] [COLOR] [COLOR] [ACCENT]

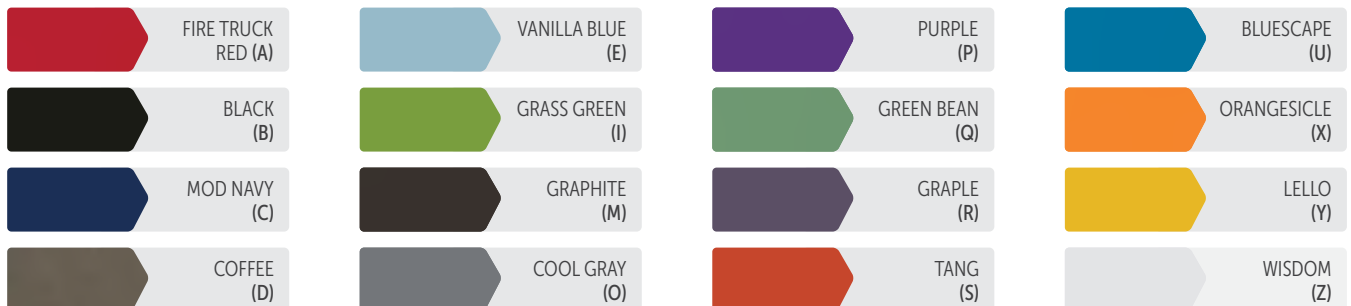

STEP 5 CASTER CHOICE

(OPTIONAL)

Choose your caster type. Refer to the Caster type key to locate the key code for your desired caster & quantity. In this example, we selected "no casters" (key code 00)

[FAMILY PART] - [WORK SURFACE] [EDGE COLOR] [FRAME COLOR] [PLASTIC ACCENT] [CASTER CHOICE]

Caster Type Key: The key codes for the caster choices consist of two characters. The first character indicates the type of caster while the second character indicates the number of casters desired.

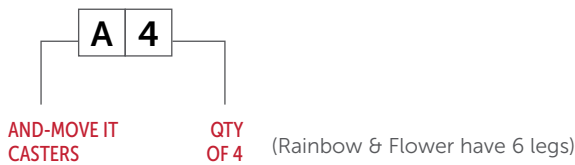

Caster Type Key

Caster	Key Code
AND-DUALIEX2	-D2
AND-DUALIEX4	-D4
AND-DUALIEX6	-D6
AND-MOVE-ITX2	-A2
AND-MOVE-ITX4	-A4
AND-MOVE-ITX6	-A6
MOVE-ITX2	-M2
MOVE-ITX4	-M4
MOVE-ITX6	-M6
NO CASTERS	-00

CASTER OPTIONS

A&D® MOVE-IT

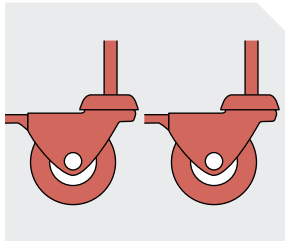

Adds 2" to overall height

A&D® DUALIE

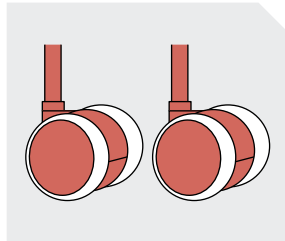

Adds 1.5" to overall height

MOVE-IT

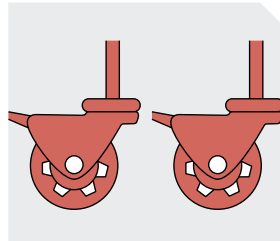

Adds 3" to overall height

MODEL NUMBERS & PRODUCT SPECS

A&D® RECTANGLE SURFACE ACTIVITY TABLE

Model #	Width (in)	Depth (in)	Overall Height (in)	Weight (lbs)	Freight Class (Qty 1)
ACTAH3060R	60	30	24 - 34	130	85
ACTEH3060R	60	30	16 - 24	130	85
ACTGH3060R	60	30	24 - 38	130	85

4 Legs



A&D® HALF ROUND SURFACE ACTIVITY TABLE

Model #	Width (in)	Depth (in)	Height (in)	Weight (lbs)	Freight Class (Qty 1)
ACTAH3060HR	60	30	24 - 34	130	85
ACTEH3060HR	60	30	16 - 24	130	85
ACTGH3060HR	60	30	24 - 38	130	85

4 Legs

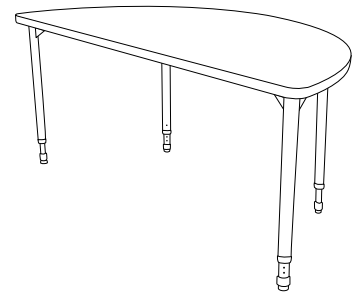

A&D® TRAPEZOID SURFACE ACTIVITY TABLE

Model #	Width (in)	Depth (in)	Height (in)	Weight (lbs)	Freight Class (Qty 1)
ACTAH3060TRAP	60	30	24 - 34	130	85
ACTEH3060TRAP	60	30	16 - 24	130	85
ACTGH3060TRAP	60	30	24 - 38	130	85

4 Legs

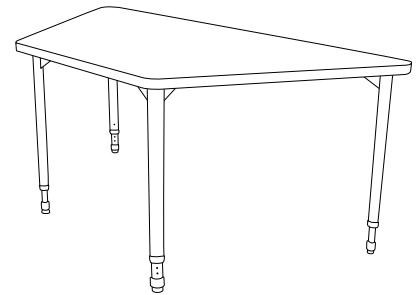

A&D® FLOWER SURFACE ACTIVITY TABLE

Model #	Width (in)	Depth (in)	Height (in)	Weight (lbs)	Freight Class (Qty 1)
ACTAH6060FLOW	60	60	24 - 34	145	85
ACTEH6060FLOW	60	60	16 - 24	145	85
ACTGH6060FLOW	60	60	24 - 38	145	85

6 Legs

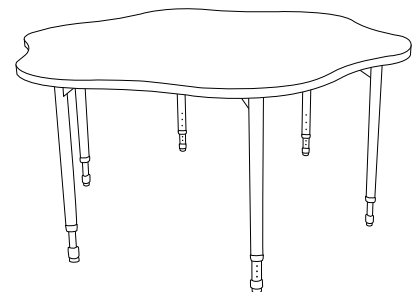

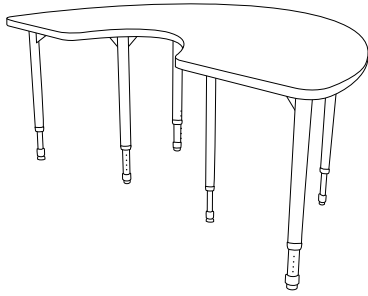

A&D® RAINBOW SURFACE ACTIVITY TABLE

Model #	Width (in)	Depth (in)	Height (in)	Weight (lbs)	Freight Class (Qty 1)
ACTAH3672RAIN	72	36	24 - 34	140	85
ACTEH3672RAIN	72	36	16 - 24	140	85
ACTGH3672RAIN	72	36	24 - 38	140	85

6 Legs

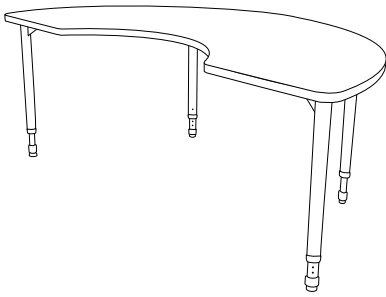

A&D® KIDNEY SURFACE ACTIVITY TABLE

Model #	Width (in)	Depth (in)	Height (in)	Weight (lbs)	Freight Class (Qty 1)
ACTAH3672KID	72	36	24 - 34	140	85
ACTEH3672KID	72	36	16 - 24	140	85
ACTGH3672KID	72	36	24 - 38	140	85

4 Legs

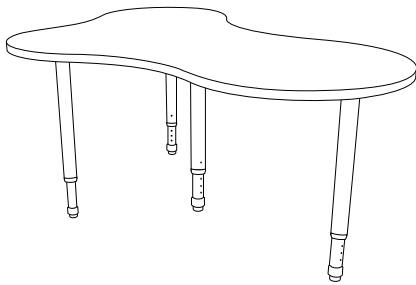

A&D® PUZZLE SURFACE ACTIVITY TABLE

Model #	Width (in)	Depth (in)	Height (in)	Weight (lbs)	Freight Class (Qty 1)
ACTAH4565PUZZ	65	45	24 - 34	140	85
ACTEH4565PUZZ	65	45	16 - 24	140	85
ACTGH4565PUZZ	65	45	24 - 38	140	85

4 Legs

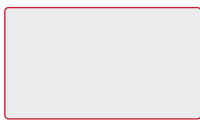

RECTANGLE
60" x 30"



TRAPEZOID
60" x 30"

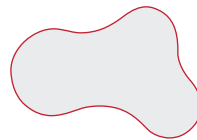

PUZZLE
65" x 45"

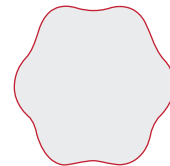

FLOWER
60" x 60"

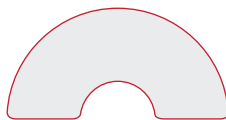

RAINBOW
72" x 36"

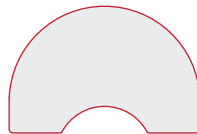

KIDNEY
72" x 36"

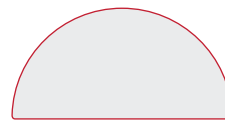

HALF ROUND
60" x 30"



MAKER® INVENT™ SERIES TABLES

Maker Invent Tables are ideal for makerspaces, STEM labs, or any environment where hands-on learning occurs. The Maker Invent was designed specifically for schools, and is built to withstand the rigors of daily makerspace activities. Maker Invent Tables are flexible, functional, durable, and look great too!

THE DIFFERENCE

There's an innate difference when you specify Paragon Furniture. We're dedicated to designing safe & eco-friendly furniture that lasts. Our products are tested to meet & exceed ANSI/BIFMA certifications. We are committed to complying with MAS Certified Green criteria & our products are assembled in the U.S.A.

BASE

The base is perforated metal powder coated metal constructed using 16-gauge steel secured to the leg assembly using hex bolts. Bases come with locking casters for easy mobility or glides for stationary applications.

STORAGE

The sides of the tables are constructed using 16-gauge steel & are equipped with 1/4" holes on 1" centers designed for pegboard hook accessories. There are 2 inner shelves that provide ample storage for makerspace equipment, tools, & other items that need to be stored.

POWER

Work surfaces provide side cutouts for power cords to be managed.

FEATURES

TOP SHAPE OPTIONS

Rectangle

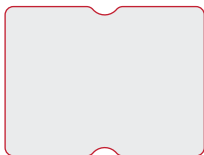

Clover

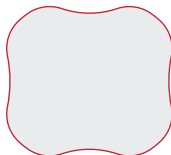

Butcher Block

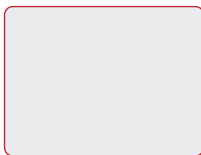

HEIGHT

Standing Height (39"), Sitting Height (30"),
Mid Height (36")

TOP MATERIAL OPTIONS

- 1-3/4" thick Maple Wood Butcher Block
(Butcher Block is coated with food-grade sealant)
- 1-1/4" thick High Pressure Laminate (HPL)
- 1-1/4" thick Chemical Resistant (HPL)
- 1-1/4" thick Phenolic
- 1-1/4" thick Chemical Resistant Phenolic



CONFIGURING A MODEL NUMBER

Refer to the Model Numbers & Product Specs section for a list of all family part model numbers in this product line. Use the chart below as a reference for how to properly specify this product.

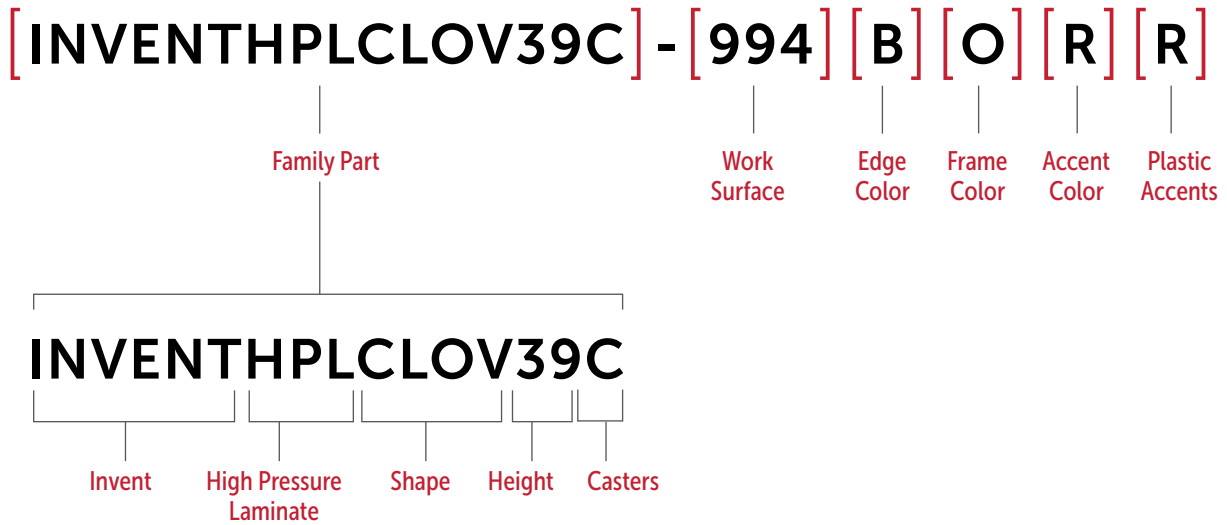

COLOR & FINISH OPTIONS

STEP 1 WORK SURFACE













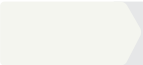

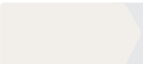

[**FAMILY PART**] - [**WORK SURFACE**]

Use the number next to the laminate name as the key code for **STEP 1**

Chemical Resistant is only available in colors marked **CR**, Phenolic is only available in colors marked **P**, and Phenolic Chemical Resistant is only available in colors marked **PCR**.



◻ SOLID LAMINATE

 PARAGON RED (910) CR P PCR	 EARTH (185) P	 FROST (918)	 CITADEL (303)
 MARS (743) P	 STORM (770) P	 NEUTRAL WHITE (123) P	 NORTH SEA GRAY (535) CR P PCR
 CLEMENTINE (852) P	 BLACK (900) CR P PCR	 FASHION GRAY (366) CR P PCR	 PLUM (736) P
 ISLAND (229) CR P PCR	 COWBOY BLUE (976) CR P PCR	 FOLKSTONE (902) P	 ORANGE GROVE (233) CR P PCR

WHITEBOARD LAMINATE



WOOD GRAIN LAMINATE

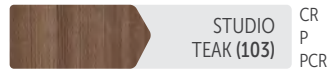
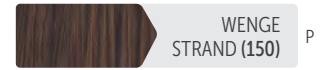

PATTERN LAMINATE

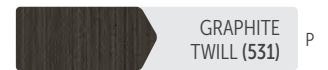

NEW COLORS

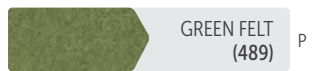
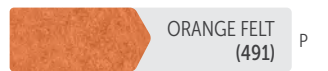
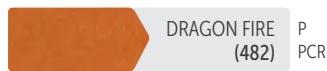
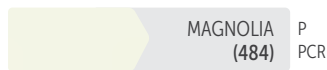

STEP 2 EDGE

Butcher Block, Phenolic, & Phenolic Chemical Resistant tops do not include specifiable edge banding.
 Choose your edge color. Use the letter next to the color name as the key code for **STEP 2**



[FAMILY] - [WORK SURFACE] [EDGE COLOR]

For laminate & color resistant work surfaces only

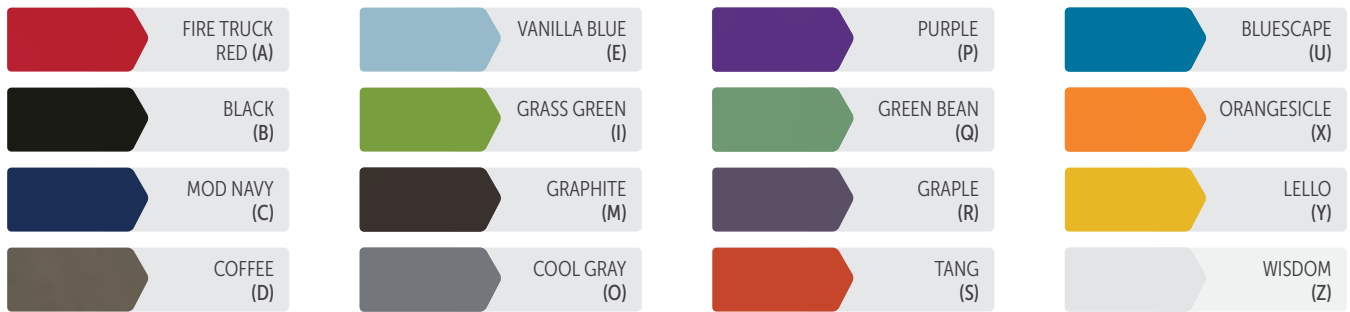

STEP 3 FRAME

Choose your frame color. Refer to the Frame Color Key to locate the key code for **STEP 3**



[FAMILY] - [WORK SURFACE] [EDGE COLOR] [FRAME COLOR]



















STEP 4 ACCENT PAINT COLOR

Use the letter next to the color name as the key code for **STEP 4**

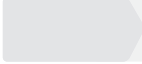

[FAMILY PART] - [WORK SURFACE] [EDGE COLOR] [FRAME COLOR] [ACCENT COLOR]

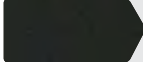





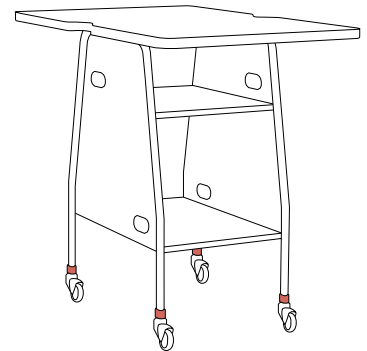







 FIRE TRUCK RED (A)	 VANILLA BLUE (E)	 PURPLE (P)	 BLUESCAPE (U)
 BLACK (B)	 GRASS GREEN (I)	 GREEN BEAN (Q)	 ORANGESICLE (X)
 MOD NAVY (C)	 GRAPHITE (M)	 GRAPLE (R)	 LELLO (Y)
 COFFEE (D)	 COOL GRAY (O)	 TANG (S)	 WISDOM (Z)
 TITANIUM (T)	 FLANNEL (F)		

STEP 5 PLASTIC ACCENTS

Use the letter next to the color name as the key code for **STEP 5**

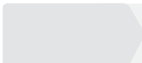

[FAMILY PART] - [WORK SURFACE] [EDGE COLOR] [FRAME COLOR] [ACCENT COLOR] [PLASTIC ACCENT]

 FIRE TRUCK RED (A)	 VANILLA BLUE (E)	 PURPLE (P)	 BLUESCAPE (U)
 BLACK (B)	 GRASS GREEN (I)	 GREEN BEAN (Q)	 ORANGESICLE (X)
 MOD NAVY (C)	 GRAPHITE (M)	 GRAPLE (R)	 LELLO (Y)
 COFFEE (D)	 COOL GRAY (O)	 TANG (S)	 WISDOM (Z)

MODEL NUMBERS & PRODUCT SPECS

MAKER® INVENT™ TABLE WITH BUTCHER BLOCK RECTANGLE WORK SURFACE

Model #	Work Surface	Width (in)	Depth (in)	Height (in)	Weight (lbs)	Seat	Glides/Casters	Freight Class (Qty 1)
INVENTBB483629	Rectangle	48	36	29	125	4	Glides	85
INVENTBB483629C	Rectangle	48	36	29	130	4	Casters	85
INVENTBB483636	Rectangle	48	36	36	125	4	Glides	85
INVENTBB483636C	Rectangle	48	36	36	130	4	Casters	85
INVENTBB483639	Rectangle	48	36	39	135	4	Glides	85
INVENTBB483639C	Rectangle	48	36	39	135	4	Casters	85

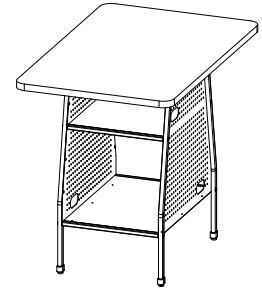

MAKER® INVENT™ TABLE WITH HIGH PRESSURE LAMINATE RECTANGLE WORK SURFACE

Model #	Work Surface	Width (in)	Depth (in)	Height (in)	Weight (lbs)	Seat	Glides/Casters	Freight Class (Qty 1)
INVENTHPL463029	Rectangle	46	30	29	105	2	Glides	85
INVENTHPL463029C	Rectangle	46	30	29	105	2	Casters	85
INVENTHPL463036	Rectangle	46	30	36	105	2	Glides	85
INVENTHPL463036C	Rectangle	46	30	36	105	2	Casters	85
INVENTHPL463039	Rectangle	46	30	39	105	2	Glides	85
INVENTHPL463039C	Rectangle	46	30	39	110	2	Casters	85
INVENTHPL463629	Rectangle	46	36	29	115	4	Glides	85
INVENTHPL463629C	Rectangle	46	36	29	115	4	Casters	85
INVENTHPL463636	Rectangle	46	36	36	115	4	Glides	85
INVENTHPL463636C	Rectangle	46	36	36	115	4	Casters	85
INVENTHPL463639	Rectangle	46	36	39	115	4	Glides	85
INVENTHPL463639C	Rectangle	46	36	39	120	4	Casters	85



MAKER® INVENT™ TABLE WITH HIGH PRESSURE LAMINATE CLOVER WORK SURFACE

Model #	Work Surface	Width (in)	Depth (in)	Height (in)	Weight (lbs)	Seat	Glides/Casters	Freight Class (Qty 1)
INVENTHPLCLOV29	Clover	44	39	29	110	4	Glides	85
INVENTHPLCLOV29C	Clover	44	39	29	115	4	Casters	85
INVENTHPLCLOV36	Clover	44	39	36	110	4	Glides	85
INVENTHPLCLOV36C	Clover	44	39	36	115	4	Casters	85
INVENTHPLCLOV39	Clover	44	39	39	115	4	Glides	85
INVENTHPLCLOV39C	Clover	44	39	39	115	4	Casters	85



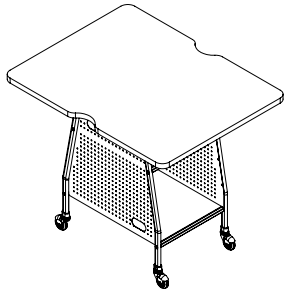

MAKER® INVENT™ TABLE WITH PHENOLIC RECTANGLE WORK SURFACE

Model #	Work Surface	Width (in)	Depth (in)	Height (in)	Weight (lbs)	Seat	Glides/Casters	Freight Class (Qty.1)
INVENTPH463029	Rectangle	46	30	29	125	2	Glides	85
INVENTPH463029C	Rectangle	46	30	29	130	2	Casters	85
INVENTPH463036	Rectangle	46	30	36	125	2	Glides	85
INVENTPH463036C	Rectangle	46	30	36	130	2	Casters	85
INVENTPH463039	Rectangle	46	30	39	135	2	Glides	85
INVENTPH463039C	Rectangle	46	30	39	130	2	Casters	85
INVENTPH463629	Rectangle	46	36	29	140	4	Glides	85
INVENTPH463629C	Rectangle	46	36	29	140	4	Casters	85
INVENTPH463636	Rectangle	46	36	36	140	4	Glides	85
INVENTPH463636C	Rectangle	46	36	36	145	4	Casters	85
INVENTPH463639	Rectangle	46	36	39	140	4	Glides	85
INVENTPH463639C	Rectangle	46	36	39	145	4	Casters	85



MAKER® INVENT™ TABLE WITH PHENOLIC CLOVER WORK SURFACE

Model #	Work Surface	Width (in)	Depth (in)	Height (in)	Weight (lbs)	Seat	Glides/Casters	Freight Class (Qty.1)
INVENTPHCLOV29	Clover	44	39	29	135	4	Glides	85
INVENTPHCLOV29C	Clover	44	39	29	140	4	Casters	85
INVENTPHCLOV36	Clover	44	39	36	135	4	Glides	85
INVENTPHCLOV36C	Clover	44	39	36	140	4	Casters	85
INVENTPHCLOV39	Clover	44	39	39	140	4	Glides	85
INVENTPHCLOV39C	Clover	44	39	39	145	4	Casters	85

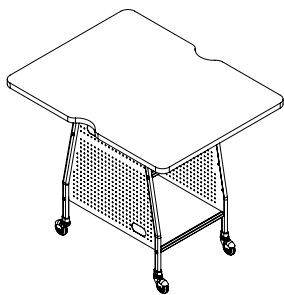

MAKER® INVENT™ TABLE WITH CHEMICAL RESISTANT RECTANGLE WORK SURFACE

Model #	Work Surface	Width (in)	Depth (in)	Height (in)	Weight (lbs)	Seat	Glides/Casters	Freight Class (Qty.1)
INVENTCR463029	Rectangle	46	30	29	105	2	Glides	85
INVENTCR463029C	Rectangle	46	30	29	105	2	Casters	85
INVENTCR463036	Rectangle	46	30	36	105	2	Glides	85
INVENTCR463036C	Rectangle	46	30	36	105	2	Casters	85
INVENTCR463039	Rectangle	46	30	39	105	2	Glides	85
INVENTCR463039C	Rectangle	46	30	39	110	2	Casters	85
INVENTCR463629	Rectangle	46	36	29	115	4	Glides	85
INVENTCR463629C	Rectangle	46	36	29	115	4	Casters	85
INVENTCR463636	Rectangle	46	36	36	115	4	Glides	85
INVENTCR463636C	Rectangle	46	36	36	115	4	Casters	85
INVENTCR463639	Rectangle	46	36	39	125	4	Glides	85
INVENTCR463639C	Rectangle	46	36	39	125	4	Casters	85

MAKER® INVENT™ TABLE WITH CHEMICAL RESISTANT CLOVER WORK SURFACE

Model #	Work Surface	Width (in)	Depth (in)	Height (in)	Weight (lbs)	Seats	Glides/Casters	Freight Class (Qty 1)
INVENTCRCLOV29	Clover	44	39	29	110	4	Glides	85
INVENTCRCLOV29C	Clover	44	39	29	115	4	Casters	85
INVENTCRCLOV36	Clover	44	39	36	110	4	Glides	85
INVENTCRCLOV36C	Clover	44	39	36	115	4	Casters	85
INVENTCRCLOV39	Clover	44	39	39	115	4	Glides	85
INVENTCRCLOV39C	Clover	44	39	39	115	4	Casters	85

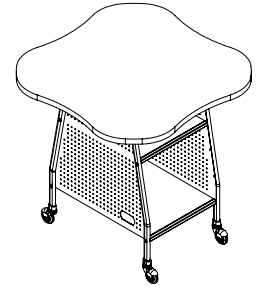

MAKER® INVENT™ TABLE WITH PHENOLIC CHEMICAL RESISTANT RECTANGLE WORK SURFACE

Model #	Work Surface	Width (in)	Depth (in)	Height (in)	Weight (lbs)	Seat	Glides/Casters	Freight Class (Qty 1)
INVENTPHC463029	Rectangle	46	30	29	130	2	Glides	85
INVENTPHC463029C	Rectangle	46	30	29	140	2	Casters	85
INVENTPHC463036	Rectangle	46	30	36	130	2	Glides	85
INVENTPHC463036C	Rectangle	46	30	36	140	2	Casters	85
INVENTPHC463039	Rectangle	46	30	39	130	2	Glides	85
INVENTPHC463039C	Rectangle	46	30	39	130	2	Casters	85
INVENTPHC463629	Rectangle	46	36	29	140	4	Glides	85
INVENTPHC463629C	Rectangle	46	36	29	140	4	Casters	85
INVENTPHC463636	Rectangle	46	36	36	140	4	Glides	85
INVENTPHC463636C	Rectangle	46	36	36	140	4	Casters	85
INVENTPHC463639	Rectangle	46	36	39	150	4	Glides	85
INVENTPHC463639C	Rectangle	46	36	39	160	4	Casters	85

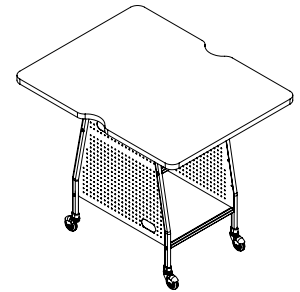

MAKER® INVENT™ TABLE WITH PHENOLIC CHEMICAL RESISTANT CLOVER WORK SURFACE

Model #	Work Surface	Width (in)	Depth (in)	Height (in)	Weight (lbs)	Seats	Glides/Casters	Freight Class (Qty 1)
INVENTPHCCLOV29	Clover	44	39	29	135	4	Glides	85
INVENTPHCCLOV29C	Clover	44	39	29	140	4	Casters	85
INVENTPHCCLOV36	Clover	44	39	36	135	4	Glides	85
INVENTPHCCLOV36C	Clover	44	39	36	140	4	Casters	85
INVENTPHCCLOV39	Clover	44	39	39	140	4	Glides	85
INVENTPHCCLOV39C	Clover	44	39	39	145	4	Casters	85

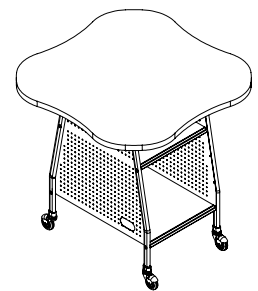



ALL-WELDED TABLES

Paragon's All-Welded Tables are ideal for various learning environments, including maker spaces. The design & construction of the fully welded frame provides added strength & durability for heavy-duty use. All-Welded Tables are flexible, functional, durable, & look great too!

FEATURES

TOP MATERIAL OPTIONS

- 1-¼" thick High Pressure Laminate (HPL)
w/ rounded corners
- 1-¼" thick Chemical Resistant HPL
w/ rounded corners
- 1-¾" thick Maple Wood Butcher Block
w/ semi-rounded corners
(Butcher Block is coated with food-grade sealant)
- 1" thick Epoxy
w/ ¼" beveled edge & square corners

ALL TERRAIN LEG FRAME

Height adjustable, 16-gauge 1 x 2" tubular frame welded to 14-gauge flattened oval tubular legs

HEIGHT

Set of four, single-post flattened-oval Paratube adjustable legs. Legs adjust using patented polypropylene 8-point bezel insert system & reinforced set screw for ease of adjustment & increased stability.



CONFIGURING A MODEL NUMBER

Refer to the Model Numbers & Product Specs section for a list of all family part model numbers in this product line. Use the chart below as a reference for how to properly specify this product.

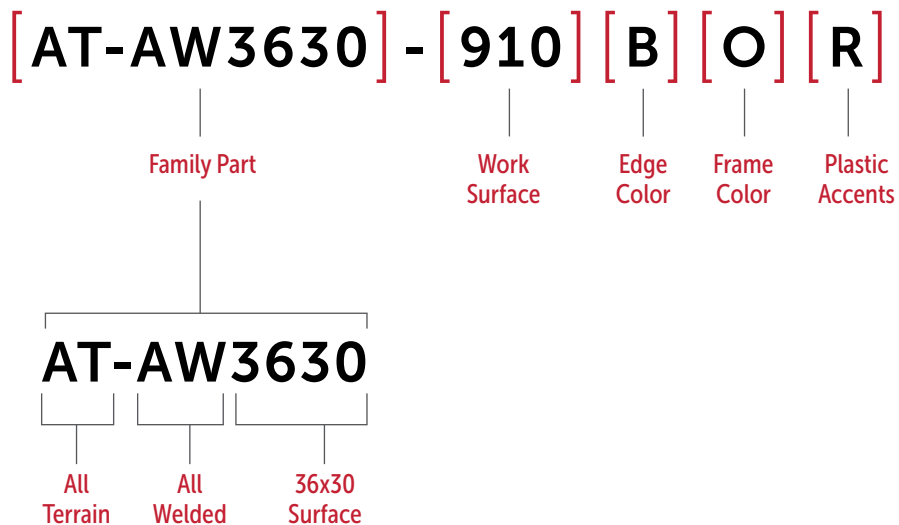

COLOR & FINISH OPTIONS





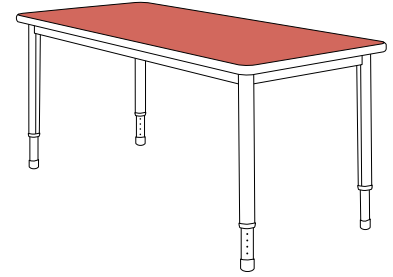







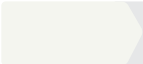

**STEP 1
LAMINATE**

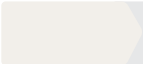
Use the number next to the laminate name as the key code for **STEP 1**
For HPL & Chemical Resistant tops only.
Chemical Resistant tops are only available in laminates marked with CR next to color box.
Epoxy tops are only available in Black.

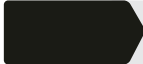
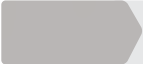

[FAMILY PART] - [WORK SURFACE]

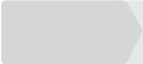
SOLID LAMINATE

 PARAGON RED (910) CR	 EARTH (185)	 FROST (918)	 CITADEL (303)
 MARS (743)	 STORM (770)	 NEUTRAL WHITE (123)	 NORTH SEA GRAY (535) CR
 CLEMENTINE (852)	 BLACK (900) CR	 FASHION GRAY (366) CR	 PLUM (736)
 ISLAND (229) CR	 COWBOY BLUE (976) CR	 FOLKSTONE (902)	 ORANGE GROVE (233) CR















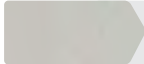

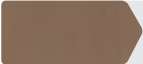
WHITEBOARD LAMINATE

 MARKERBOARD WHITE (988) CR

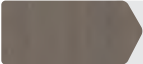
WOOD GRAIN LAMINATE

 HIGH RISE (857) CR	 RIVER CHERRY (566) CR	 XANADU (110) CR	 WENGE STRAND (150)
 KENSINGTON MAPLE (963)	 STUDIO TEAK (103) CR	 WHEAT STRAND (179)	 BURNT STRAND (400)

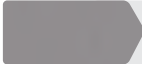
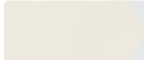
PATTERN LAMINATE

 WHITE NEBULA (215) CR	 CARBON EV (890)	 CLASSIC LINEN (155) CR	 NAVY LEGACY (985) CR
 CRISP LINEN (122) CR	 CITADEL WARP (511)	 EARTHEN WARP (119)	 GRAPHITE TWILL (531)
 WASHI CRYSTAL (440) CR	 GRAPHITE NEBULA (994)	 EARTHEN TWILL (161)	 GRAY NEBULA (102)
 WASHI PEWTER (441) CR	 CLOUD NEBULA (315) CR	 SARUM TWILL (242)	 PRESSED LINEN (858) CR
 NEUTRAL WEFT (112)	 TAILORED LINEN (859) CR	 NEUTRAL TWILL (306)	

NEW COLORS



Butcher Block & Epoxy tops do not include specifiable edge banding.

STEP 2
EDGE

Use the letter next to the color name as the key code for **STEP 2**

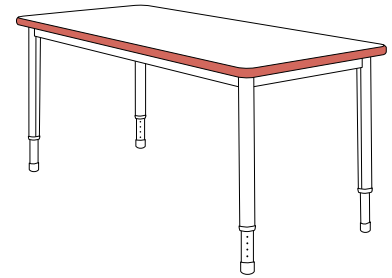

[FAMILY] - [WORK SURFACE] [EDGE COLOR]

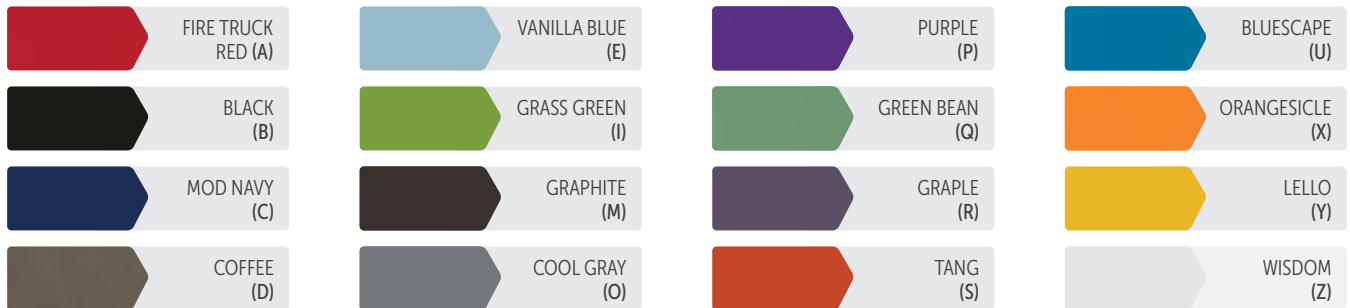

STEP 3 FRAME

Use the letter next to the color name as the key code for **STEP 3**

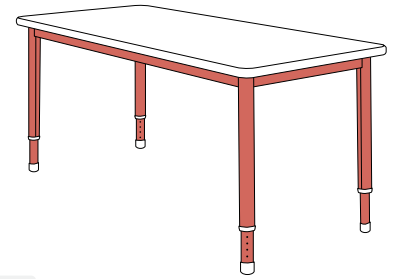

[FAMILY] - [WORK SURFACE] [EDGE COLOR] [FRAME COLOR]



STEP 4 PLASTIC ACCENTS

Use the letter next to the color name as the key code for **STEP 4**

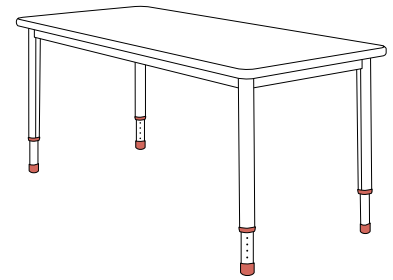

[FAMILY] - [WORK SURFACE] [EDGE COLOR] [FRAME COLOR] [PLASTIC ACCENT]





MODEL NUMBERS & PRODUCT SPECS

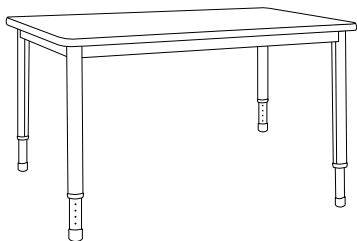

ALL WELDED TABLE: HIGH-PRESSURE LAMINATE TOP

Model #	Width (in)	Depth (in)	Overall Height (in)	Weight (lbs)	Dist. Between Legs (in)	Freight Class (Qty 1)
AT-AW3624-HPL	36	24	24.5-35.5	65	22	300
AT-AW4824-HPL	48	24	24.5-35.5	75	40	250
AT-AW5424-HPL	54	24	24.5-35.5	80	47	300
AT-AW6024-HPL	60	24	24.5-35.5	90	52	300
AT-AW7224-HPL	72	24	24.5-35.5	100	64	300
AT-AW3630-HPL	36	30	24.5-35.5	75	22	250
AT-AW4830-HPL	48	30	24.5-35.5	85	40	250
AT-AW5430-HPL	54	30	24.5-35.5	95	47	300
AT-AW6030-HPL	60	30	24.5-35.5	100	52	250
AT-AW7230-HPL	72	30	24.5-35.5	115	64	250

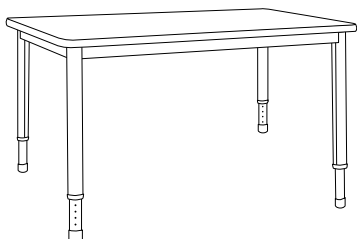

ALL WELDED TABLE: CHEMICAL RESISTANT TOP

Model #	Width (in)	Depth (in)	Overall Height (in)	Weight (lbs)	Dist. Between Legs (in)	Freight Class (Qty 1)
AT-AW3624-CR	36	24	24.5-35.5	65	22	300
AT-AW4824-CR	48	24	24.5-35.5	75	40	250
AT-AW5424-CR	54	24	24.5-35.5	80	47	300
AT-AW6024-CR	60	24	24.5-35.5	90	52	300
AT-AW7224-CR	72	24	24.5-35.5	100	64	300
AT-AW3630-CR	36	30	24.5-35.5	75	22	250
AT-AW4830-CR	48	30	24.5-35.5	85	40	250
AT-AW5430-CR	54	30	24.5-35.5	95	47	300
AT-AW6030-CR	60	30	24.5-35.5	100	52	250
AT-AW7230-CR	72	30	24.5-35.5	115	64	250

ALL WELDED TABLE: EPOXY TOP

Model #	Width (in)	Depth (in)	Overall Height (in)	Weight (lbs)	Dist. Between Legs (in)	Freight Class (Qty 1)
AT-AW3624-EP	36	24	24.5-35.5	105	22	250
AT-AW4824-EP	48	24	24.5-35.5	130	40	250
AT-AW5424-EP	54	24	24.5-35.5	145	47	250
AT-AW6024-EP	60	24	24.5-35.5	160	52	250
AT-AW7224-EP	72	24	24.5-35.5	185	64	250
AT-AW3630-EP	36	30	24.5-35.5	125	22	250
AT-AW4830-EP	48	30	24.5-35.5	155	40	250
AT-AW5430-EP	54	30	24.5-35.5	175	47	250
AT-AW6030-EP	60	30	24.5-35.5	190	52	250
AT-AW7230-EP	72	30	24.5-35.5	220	64	250

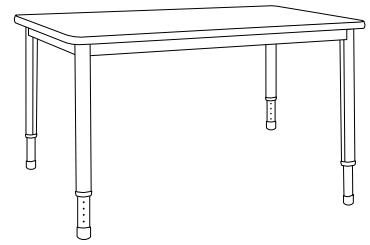

ALL WELDED TABLE: BUTCHER BLOCK TOP

Model #	Width (in)	Depth (in)	Overall Height (in)	Weight (lbs)	Dist. Between Legs (in)	Freight Class (Qty 1)
AT-AW3624-BB	36	24	24.5-35.5	105	22	250
AT-AW4824-BB	48	24	24.5-35.5	130	40	250
AT-AW5424-BB	54	24	24.5-35.5	145	47	250
AT-AW6024-BB	60	24	24.5-35.5	160	52	250
AT-AW7224-BB	72	24	24.5-35.5	185	64	250
AT-AW4830-BB	48	30	24.5-35.5	155	40	250
AT-AW6030-BB	60	30	24.5-35.5	190	52	250
AT-AW7230-BB	72	30	24.5-35.5	220	64	250

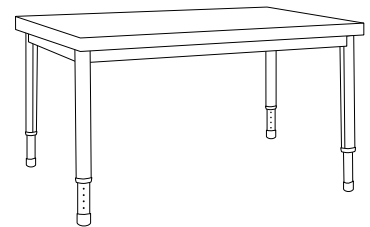

ACCESSORIES

Model #	Width (in)	Depth (in)	Overall Height (in)	Weight (lbs)	Freight Class (Qty 1)
MOVE-ITx2	N/A	N/A	4	5	85
MOVE-ITx4	N/A	N/A	4	5	85
IT-AT LEG WIRE	3	1.5	18	5	85
PD-FLIP-USB	4.5"R	4.5"R	4	5	85

(PD-FLIP-USB cannot be used on Epoxy or Butcher Block tops)

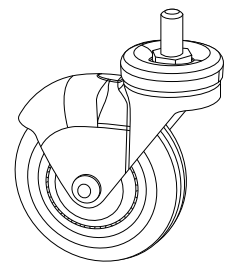



CHARGE BAR TABLES

Chargebar Tables create an ideal touchdown place to power up your devices & get some work done. The tables are built on an all-welded steel frame with a high-density HPL top. Chargebars are available in standing height or sitting height & come with Paragon's PD-Flip pop-up power, three outlet, two USB port surge protector.

FEATURES

○ SURFACE/EDGE

1 1/4" HPL with machine applied durable edge band.

○ FRAME

16-gauge 1x2" tubular frame welded to 14-gauge flattened oval tubular legs.

○ PD-FLIP

Pop-up power, 3 outlet, 2 USB port surge protector.

○ HEIGHT OPTIONS

Available in Standing Height of 42" as well as standard Sitting Height of 30".

○ COLOR OPTIONS

Five frame paint options with your choice of standard laminate colors for your top surface & multiple accents to choose from.



PD-Flip



CONFIGURING A MODEL NUMBER

Refer to the Model Numbers & Product Specs section for a list of all family part model numbers in this product line. Use the chart below as a reference for how to properly specify this product.

[**AT-AW-CHARGE BAR-722430**] - [**910**] [**B**] [**O**] [**R**]

Family Part

Work
Surface

Edge
Color

Frame
Color

Accent
Color

AT-AW-CHARGE BAR-722430

All-Terrain All-Welded

Chargebar

Table Dimensions

COLOR & FINISH OPTIONS

STEP 1 LAMINATE

Use the number next to the laminate name as the key code for **STEP 1**

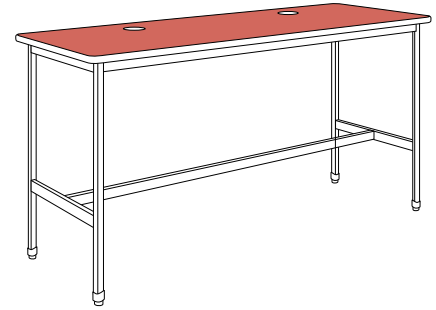

[FAMILY] - [WORK]
[PART] - [SURFACE]

SOLID LAMINATE

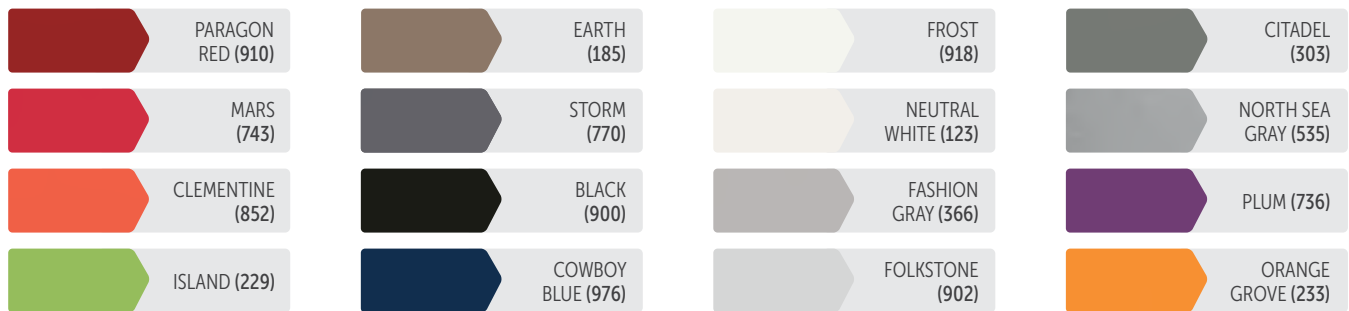

WHITEBOARD LAMINATE



WOOD GRAIN LAMINATE

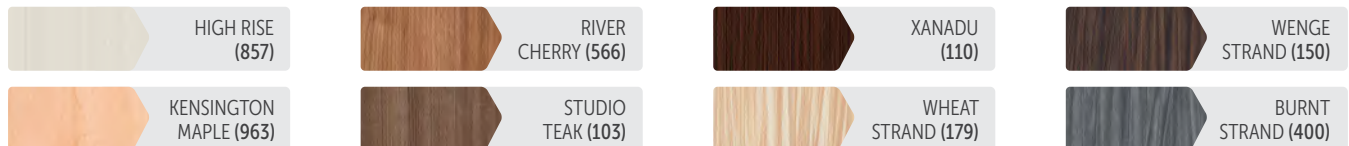

PATTERN LAMINATE





NEW COLORS



STEP 2
EDGE

Use the letter next to the color name as the key code for **STEP 2**

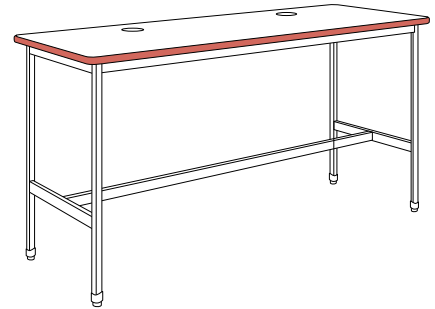

[FAMILY] - [WORK SURFACE] [EDGE COLOR]

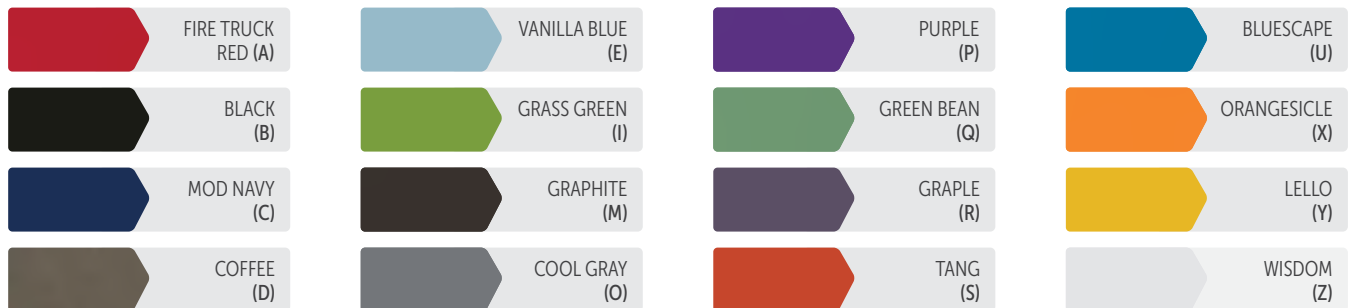

STEP 3 FRAME

Use the letter next to the color name as the key code for **STEP 3**

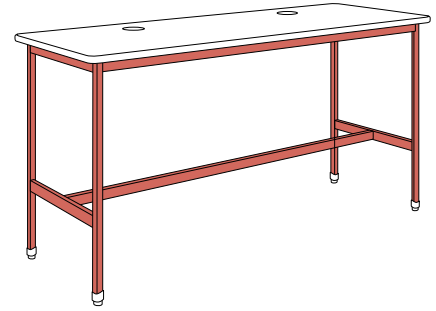

[FAMILY] - [WORK SURFACE] [EDGE COLOR] [FRAME COLOR]



BLACK
(B)



TITANIUM
(T)



WISDOM
(Z)



FLANNEL
(F)



COOL GRAY
(O)

STEP 4 PLASTIC ACCENTS

Use the letter next to the color name as the key code for **STEP 4**

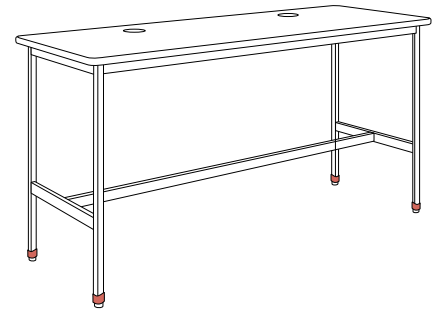

[FAMILY] - [WORK SURFACE] [EDGE COLOR] [FRAME COLOR] [PLASTIC ACCENT]



FIRE TRUCK
RED (A)



VANILLA BLUE
(E)



PURPLE
(P)



BLUESCAPE
(U)



BLACK
(B)



GRASS GREEN
(I)



GREEN BEAN
(Q)



ORANGESICLE
(X)



MOD NAVY
(C)



GRAPHITE
(M)



GRAPLE
(R)



LELLO
(Y)



COFFEE
(D)



COOL GRAY
(O)



TANG
(S)



WISDOM
(Z)

MODEL NUMBERS & PRODUCT SPECS

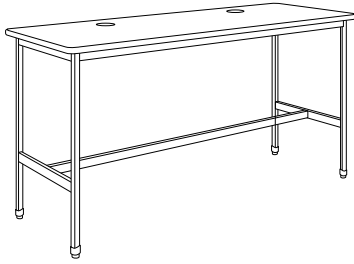

CHARGE BAR TABLES

Model #	Width (in)	Depth (in)	Height (in)	Weight (lbs)	Dist. Between Legs (in)	Freight Class (Qty 1)
AT-AW-CHARGE BAR-722430	72	24	30	150	65	150
AT-AW-CHARGE BAR-722442	72	24	42	160	65	150
AT-AW-CHARGE BAR-842430	84	24	30	190	77	150
AT-AW-CHARGE BAR-842442	84	24	42	200	77	150
AT-AW-CHARGE BAR-962430	96	24	30	230	89	150
AT-AW-CHARGE BAR-962442	96	24	42	240	89	150
AT-AW-CHARGE BAR-723030	72	30	30	170	65	150
AT-AW-CHARGE BAR-723042	72	30	42	180	65	150
AT-AW-CHARGE BAR-843030	84	30	30	210	77	150
AT-AW-CHARGE BAR-843042	84	30	42	220	77	150
AT-AW-CHARGE BAR-963030	96	30	30	250	89	150
AT-AW-CHARGE BAR-963042	96	30	42	260	89	150

POWER PLACEMENT

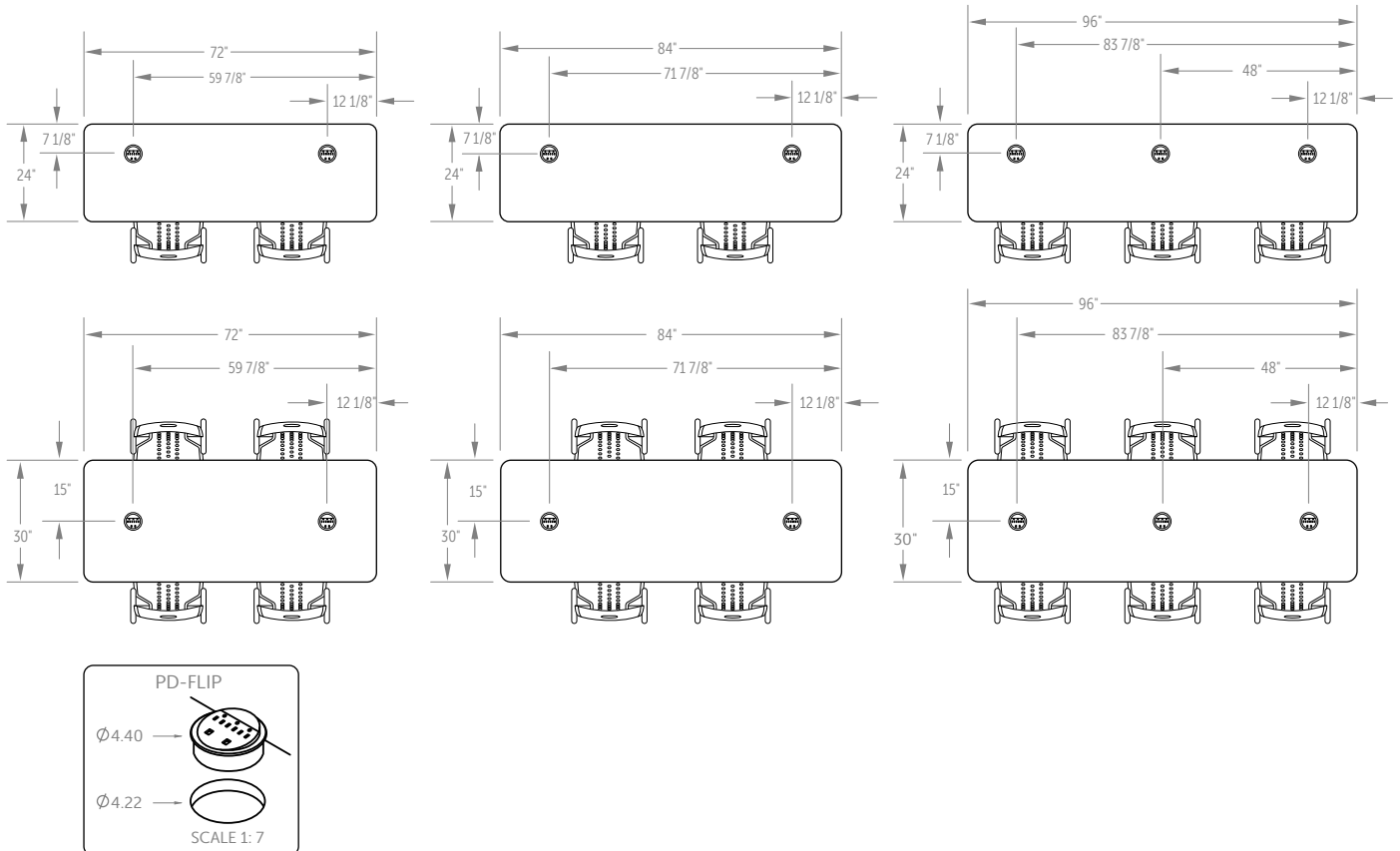



TRAIN-IT TABLE

The Train-IT Table provides maximum user comfort, an attractive design & sturdy construction. Ideal for desktop computers, this eco friendly computer training table features a J-channel cable manager to keep cords neat & organized.

HOW TO SPECIFY

Training table with perforated J-channel wire management trough & 1 1/4" High Pressure Laminate surface. Legs are single post flattened-oval steel that adjust in height in one-inch increments using an 8 contact-point bezel sleeve for extra support.

FEATURES

○ SURFACE/EDGE

1 1/4" HPL with machine applied durable edge band.

○ HEIGHT

Patented height adjustment bezel sleeve provides all units a height range from 24.5" to 35.5".

○ FRAME

Standard single post leg 14-gauge steel tube & leg lower is 16-gauge steel with perforated 1/4" holes every inch to allow for height adjustment bezel sleeve that contacts leg insert at 8 contact points. Molded plastic end cap.

○ COLOR OPTIONS

Five frame paint options with your choice of standard laminate colors for your top surface & multiple accents to choose from.

○ CABLE MANAGEMENT

Computer training table with perforated J-channel wire manager as standard.

○ CASTERS

Deluxe skater casters; Available in sets of 2 locking casters (MOVE-ITx2) or sets of 4 casters, 2 locking & 2 non-locking (MOVE-ITx4).



CONFIGURING A MODEL NUMBER

Refer to the Model Numbers & Product Specs section for a list of all family part model numbers in this product line. Use the chart below as a reference for how to properly specify this product.

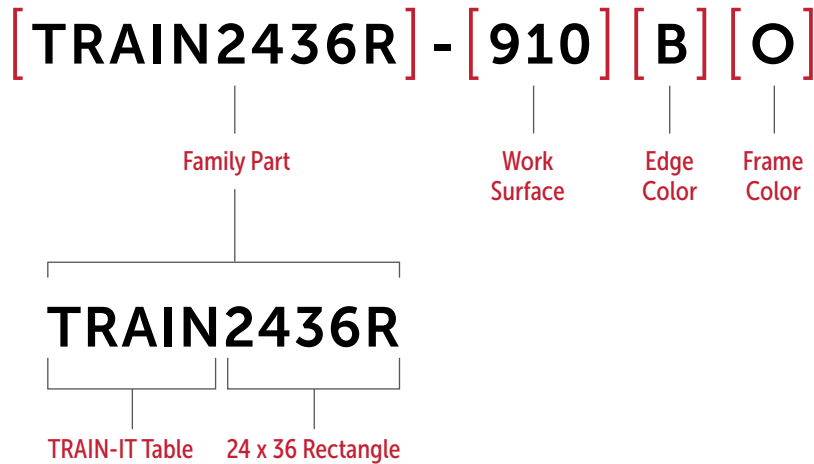

COLOR & FINISH OPTIONS





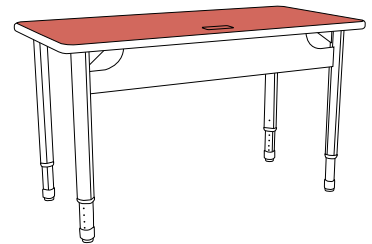







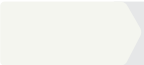

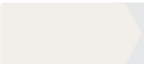

STEP 1 WORK SURFACE

Use the number next to the laminate name as the key code for **STEP 1**



[**FAMILY PART**] - [**WORK SURFACE**]

SOLID LAMINATE

 PARAGON RED (910)	 EARTH (185)	 FROST (918)	 CITADEL (303)
 MARS (743)	 STORM (770)	 NEUTRAL WHITE (123)	 NORTH SEA GRAY (535)
 CLEMENTINE (852)	 BLACK (900)	 FASHION GRAY (366)	 PLUM (736)
 ISLAND (229)	 COWBOY BLUE (976)	 FOLKSTONE (902)	 ORANGE GROVE (233)

WHITEBOARD LAMINATE



WOOD GRAIN LAMINATE

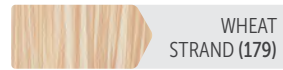
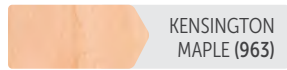

PATTERN LAMINATE

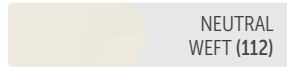

NEW COLORS

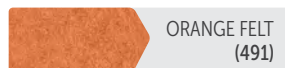
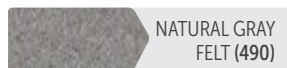
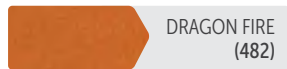

STEP 2 EDGE

Use the letter next to the color name as the key code for **STEP 2**

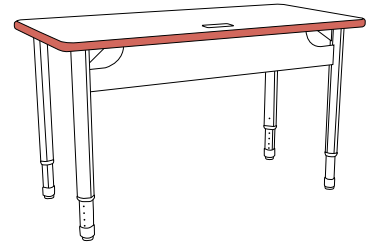

[FAMILY PART] - [WORK SURFACE] [EDGE COLOR]

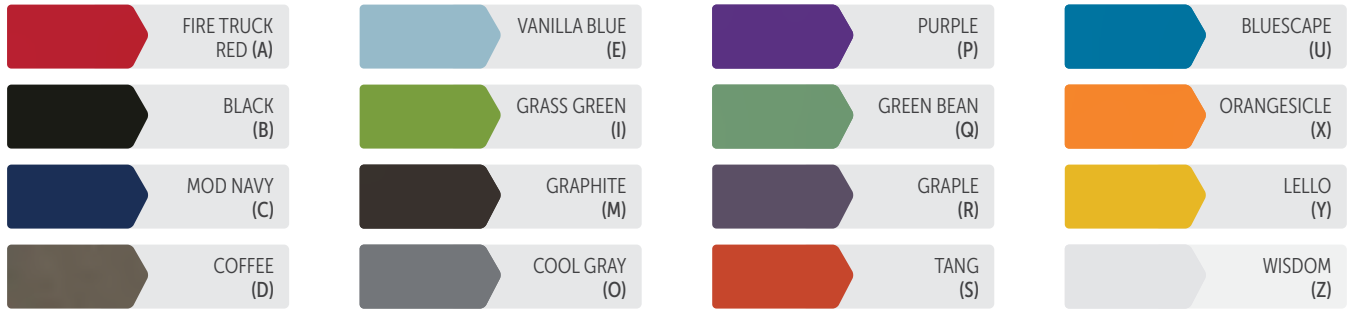

STEP 3 FRAME

Use the letter next to the color name as the key code for **STEP 3**

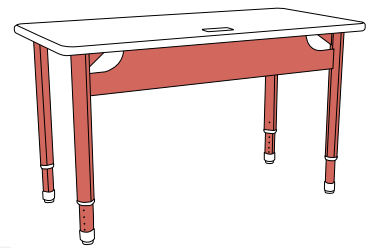

[FAMILY PART] - [WORK SURFACE] [EDGE COLOR] [FRAME COLOR]



STEP 4 PLASTIC ACCENTS

Use the letter next to the color name as the key code for **STEP 4**

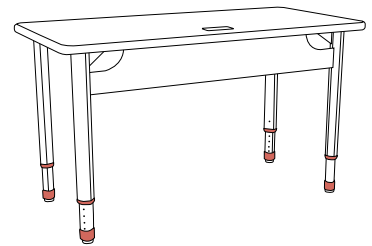

[FAMILY PART] - [WORK SURFACE] [EDGE COLOR] [FRAME COLOR] [PLASTIC ACCENT]

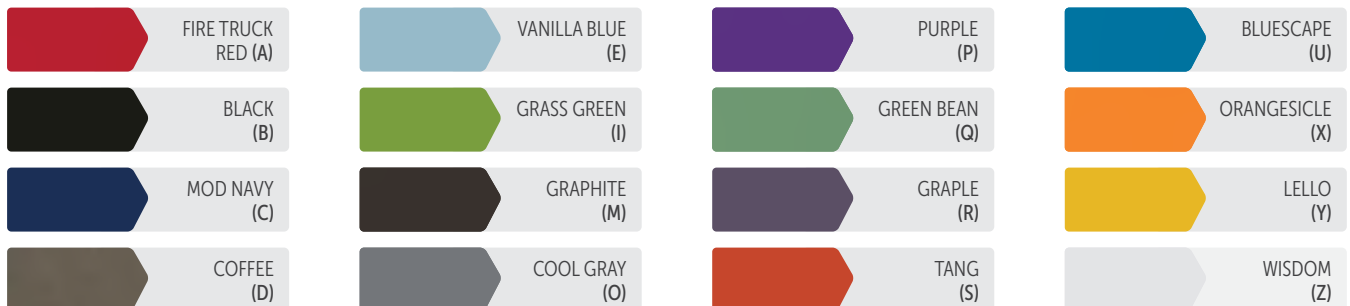

MODEL NUMBERS & PRODUCT SPECS

TRAIN-IT TABLE

Model #	Width (in)	Depth (in)	Height (in)	Weight (lbs)	Freight Class (Qty 1)
TRAIN2436R	36	24	24.5 - 35.5	50	85
TRAIN2448R	48	24	24.5 - 35.5	90	85
TRAIN2460R	60	24	24.5 - 35.5	100	85
TRAIN2472R	72	24	24.5 - 35.5	110	85
TRAIN3036R	36	30	24.5 - 35.5	90	85
TRAIN3048R	48	30	24.5 - 35.5	105	85
TRAIN3060R	60	30	24.5 - 35.5	125	85
TRAIN3072R	72	30	24.5 - 35.5	145	85

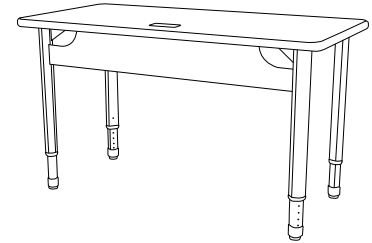

ACCESSORIES

Part #	Width (in)	Depth (in)	Height (in)	Weight (lbs)	Freight Class (Qty 1)
MOVE-ITx2	N/A	N/A	4	5	85
MOVE-ITx4	N/A	N/A	4	5	85
IT-AT LEG WIRE	3	1.5	18	5	85
PD-FLIP-USB	4.5 R	4.5 R	4	5	85

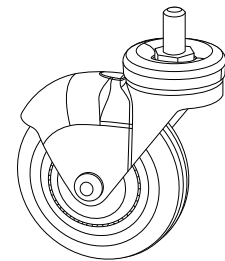

FOR TRAIN-ITS SHORTER THAN 60" (TABLES WITH ONE GROMMET)

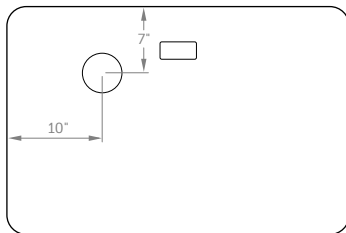

PDF1L = 1PD FLIP ON LEFT

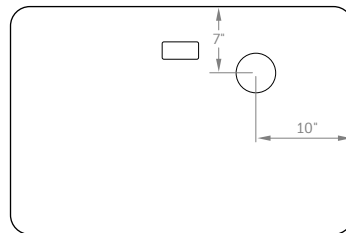

PDF1R = 1PD FLIP ON RIGHT

FOR TRAIN-ITS 60" OR LONGER (TABLES WITH ONE GROMMET)

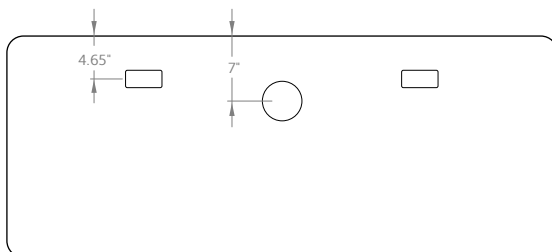

1PD FLIP IN CENTER

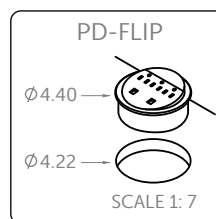



COMPUTE-IT COMPUTER TABLE

The table offers a simple solution for desktop and laptop computers. The perforated wire management tray opens for easy access & keeps cables neat & organized.

FEATURES

○ SURFACE/EDGE

1 1/4" HPL with machine applied durable edge band.

○ SHAPES

Rectangle & Scalloped.

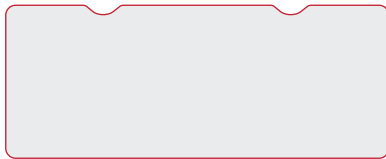

Rectangle



Scalloped

○ HEIGHT

Legs adjust from 23.5" - 34.5" using patented polypropylene 8 point bezel insert system & reinforced set screw for ease of adjustment & increased stability.

○ FRAME

Paratube flattened oval steel frame with polypropylene accents.

○ COLOR OPTIONS

Five frame paint options with your choice of standard laminate colors for your top surface & multiple accents to choose from.

○ CABLE MANAGEMENT

Enclosed 8-gauge perforated steel wire manager that pivots for wire access.

○ OPTIONS

Available with casters, table-top power or CPU holder.



CONFIGURING A MODEL NUMBER

Refer to the Model Numbers & Product Specs section for a list of all family part model numbers in this product line. Use the chart below as a reference for how to properly specify this product.

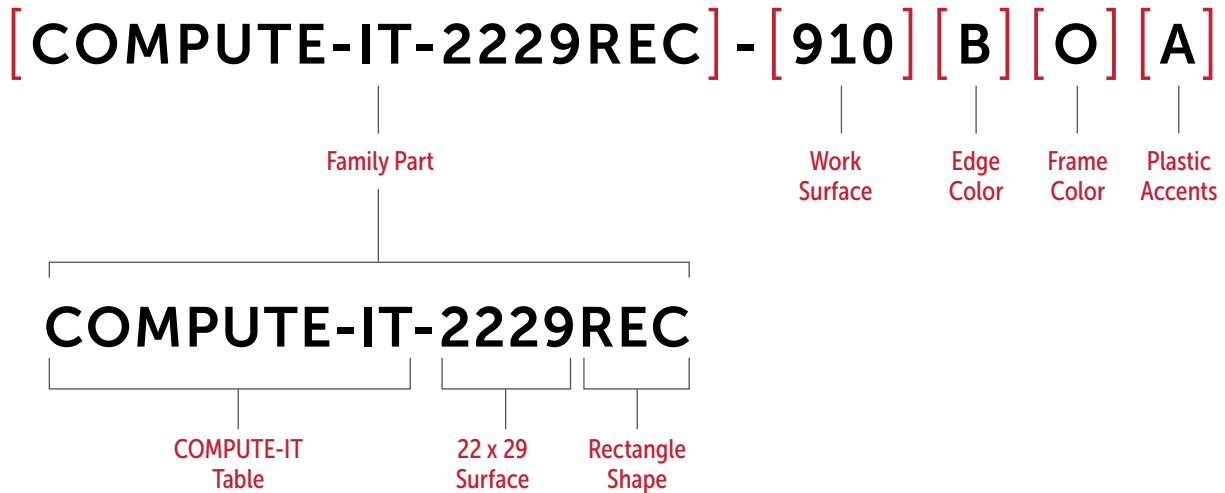

COLOR & FINISH OPTIONS





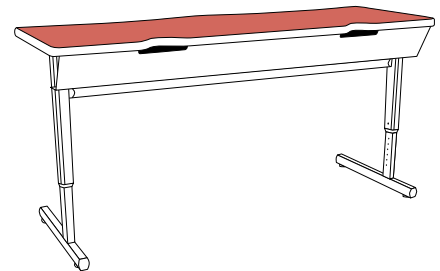







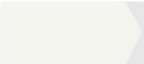



STEP 1 WORK SURFACE

Use the number next to the laminate name as the key code for **STEP 1**



[**FAMILY PART**] - [**WORK SURFACE**]

SOLID LAMINATE

 PARAGON RED (910)	 EARTH (185)	 FROST (918)	 CITADEL (303)
 MARS (743)	 STORM (770)	 NEUTRAL WHITE (123)	 NORTH SEA GRAY (535)
 CLEMENTINE (852)	 BLACK (900)	 FASHION GRAY (366)	 PLUM (736)
 ISLAND (229)	 COWBOY BLUE (976)	 FOLKSTONE (902)	 ORANGE GROVE (233)

WHITEBOARD LAMINATE



WOOD GRAIN LAMINATE

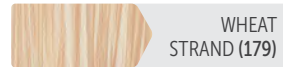
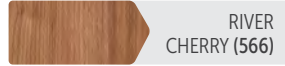

PATTERN LAMINATE

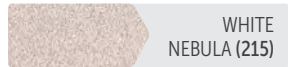

NEW COLORS

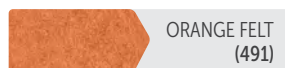
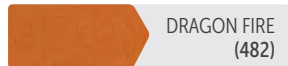





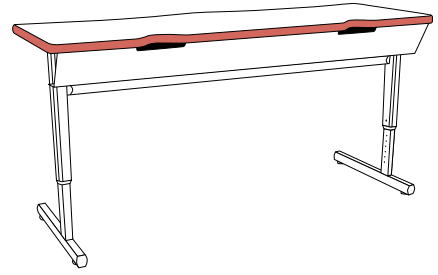







STEP 2 EDGE

Use the letter next to the color name as the key code for **STEP 2**

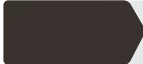

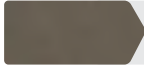
[FAMILY PART] - [WORK SURFACE] [EDGE COLOR]

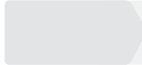
 FIRE TRUCK RED (A)	 VANILLA BLUE (E)	 PURPLE (P)	 BLUESCAPE (U)
 BLACK (B)	 GRASS GREEN (I)	 GREEN BEAN (Q)	 ORANGESICLE (X)
 MOD NAVY (C)	 GRAPHITE (M)	 GRAPLE (R)	 LELLO (Y)
 COFFEE (D)	 COOL GRAY (O)	 TANG (S)	 WISDOM (Z)

STEP 3 FRAME

Use the letter next to the color name as the key code for **STEP 3**

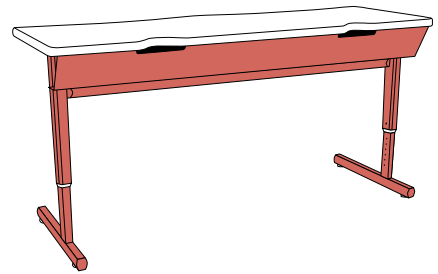

[FAMILY PART] - [WORK SURFACE] [EDGE COLOR] [FRAME COLOR]







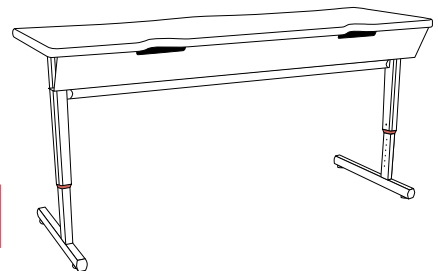







 BLACK (B)	 TITANIUM (T)	
 FLANNEL (F)	 COOL GRAY (O)	 WISDOM (Z)

STEP 4 PLASTIC ACCENTS

Use the letter next to the color name as the key code for **STEP 4**

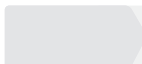

[FAMILY PART] - [WORK SURFACE] [EDGE COLOR] [FRAME COLOR] [PLASTIC ACCENT]

 FIRE TRUCK RED (A)	 VANILLA BLUE (E)	 PURPLE (P)	 BLUESCAPE (U)
 BLACK (B)	 GRASS GREEN (I)	 GREEN BEAN (Q)	 ORANGESICLE (X)
 MOD NAVY (C)	 GRAPHITE (M)	 GRAPLE (R)	 LELLO (Y)
 COFFEE (D)	 COOL GRAY (O)	 TANG (S)	 WISDOM (Z)

MODEL NUMBERS & PRODUCT SPECS

COMPUTE-IT RECTANGLE TABLES

Model #	Width (in)	Depth (in)	Height (in)	Weight (lbs)	Freight Class (Qty 1)
COMPUTE-IT-2229REC	29	22	23.5 - 34.5	50	85
COMPUTE-IT-22260REC	60	22	23.5 - 34.5	100	85
COMPUTE-IT-22272REC	72	22	23.5 - 34.5	120	85
COMPUTE-IT-2429REC	29	24	23.5 - 34.5	50	85
COMPUTE-IT-24260REC	60	24	23.5 - 34.5	100	85
COMPUTE-IT-24272REC	72	24	23.5 - 34.5	120	85

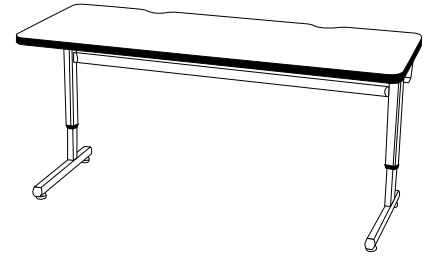

COMPUTE-IT TABLES WITH SCALLOPED EDGE

Model #	Width (in)	Depth (in)	Height (in)	Weight (lbs)	Freight Class (Qty 1)
COMPUTE-IT-2229S	29	22	23.5 - 34.5	50	85
COMPUTE-IT-22260S	60	22	23.5 - 34.5	100	85
COMPUTE-IT-22272S	72	22	23.5 - 34.5	120	85
COMPUTE-IT-2429S	29	24	23.5 - 34.5	50	85
COMPUTE-IT-24260S	60	24	23.5 - 34.5	100	85
COMPUTE-IT-24272S	72	24	23.5 - 34.5	120	85



ACCESSORIES

Part #	Width (in)	Depth (in)	Height (in)	Weight (lbs)	Freight Class (Qty 1)
MOVE-ITX2	N/A	N/A	4	5	85
MOVE-ITX4	N/A	N/A	4	5	85
IT-AT-LEG-WIRE	3	1.5	18	5	85
PD-FLIP-USB	4.5 R	4.5 R	N/A	5	85
IT-CPU	12	5	18	10	85

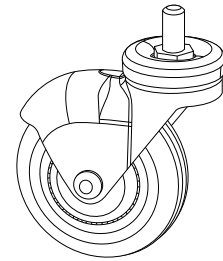

PD-FLIP PLACEMENT OPTIONS

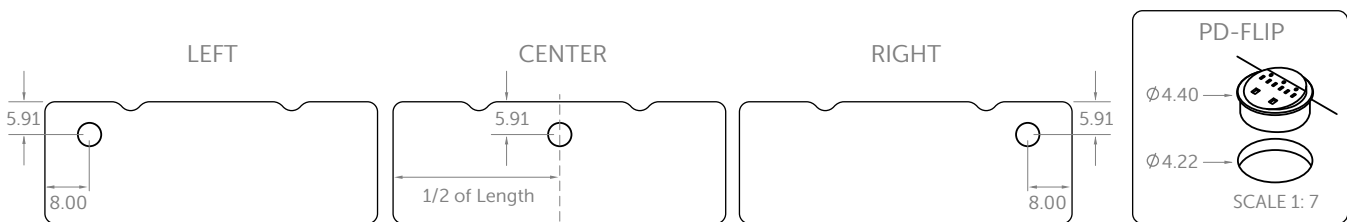



READ-IT TABLES

Read-IT flexible learning tables are designed to work in multiple applications & for a variety of users. Available with a tombstone, round or rectangular top. Tables are height adjustable from 24.5" - 35.5" for adults & children.

FEATURES

TOP SHAPE OPTIONS



Rectangular



Rectangle Tombstone

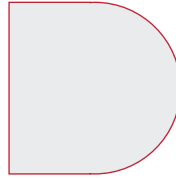

Bullet

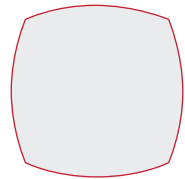

Square Tombstone



Square

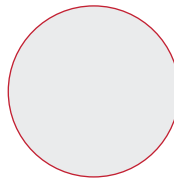

Round

SURFACE/EDGE

1 1/4" HPL with machine applied durable edge band.

HEIGHT

Patent-pending height adjustment bezel sleeve provides all units a height range from 24.5" to 35.5".

FRAME

Set of four, single-post flattened-oval Paratube adjustable legs. Frame allows table to adjust in height from 24.5" - 35.5". Legs adjust using patented polypropylene 8-point bezel insert system & reinforced set screw for ease of adjustment & increased stability.

COLOR OPTIONS

Five frame paint options with your choice of standard laminate colors for your top surface & multiple accents to choose from.

OPTIONAL CASTERS

Deluxe skater casters; Available in sets of 2 locking casters (MOVE-ITx2) or sets of 4 casters, 2 locking & 2 non-locking (MOVE-ITx4).



CONFIGURING A MODEL NUMBER

Refer to the Model Numbers & Product Specs section for a list of all family part model numbers in this product line. Use the chart below as a reference for how to properly specify this product.

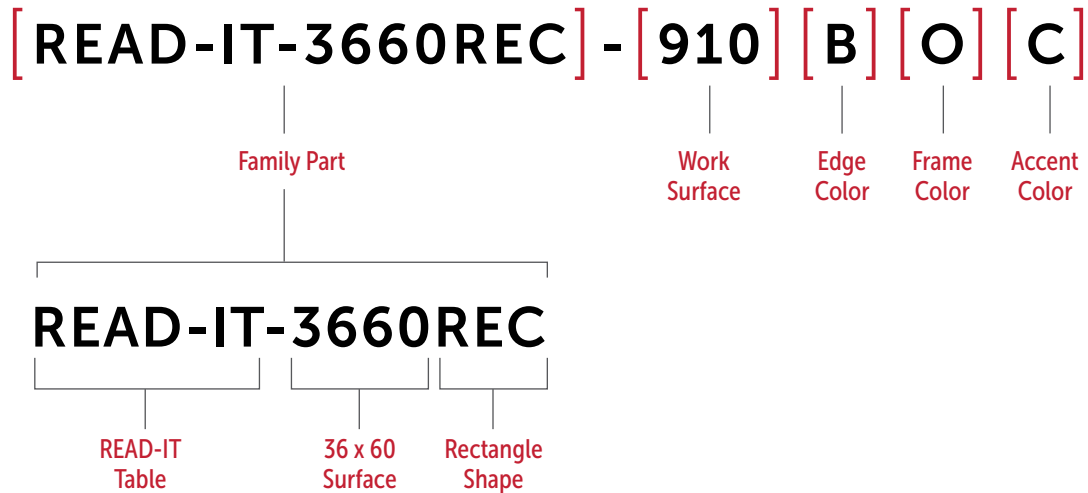

COLOR & FINISH OPTIONS





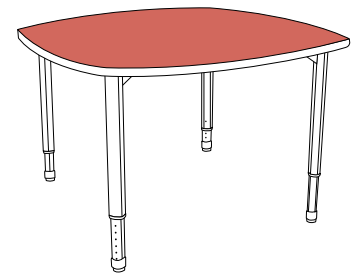









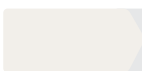

STEP 1 WORK SURFACE

Use the number next to the laminate name as the key code for **STEP 1**



[**FAMILY PART**] - [**WORK SURFACE**]

◻ SOLID LAMINATE

 PARAGON RED (910)	 EARTH (185)	 FROST (918)	 CITADEL (303)
 MARS (743)	 STORM (770)	 NEUTRAL WHITE (123)	 NORTH SEA GRAY (535)
 CLEMENTINE (852)	 BLACK (900)	 FASHION GRAY (366)	 PLUM (736)
 ISLAND (229)	 COWBOY BLUE (976)	 FOLKSTONE (902)	 ORANGE GROVE (233)

WHITEBOARD LAMINATE

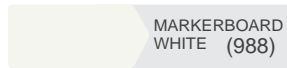

WOOD GRAIN LAMINATE

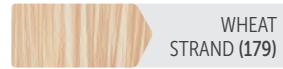
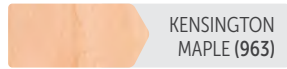
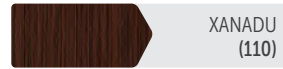

PATTERN LAMINATE

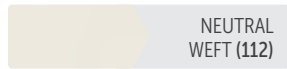

NEW COLORS

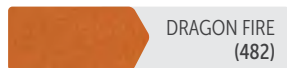
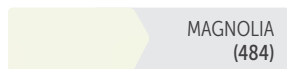





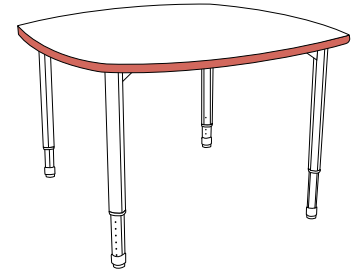







STEP 2 EDGE

Use the letter next to the color name as the key code for **STEP 2**

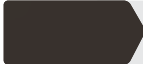

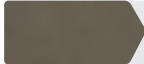
[FAMILY PART] - [WORK SURFACE] [EDGE COLOR]

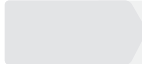
 FIRE TRUCK RED (A)	 VANILLA BLUE (E)	 PURPLE (P)	 BLUESCAPE (U)
 BLACK (B)	 GRASS GREEN (I)	 GREEN BEAN (Q)	 ORANGESICLE (X)
 MOD NAVY (C)	 GRAPHITE (M)	 GRAPLE (R)	 LELLO (Y)
 COFFEE (D)	 COOL GRAY (O)	 TANG (S)	 WISDOM (Z)

STEP 3 FRAME

Use the letter next to the color name as the key code for **STEP 3**

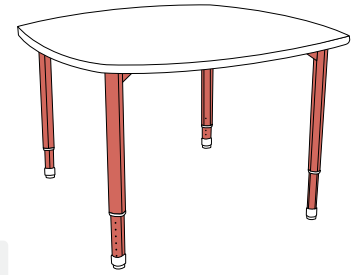

[FAMILY PART] - [WORK SURFACE] [EDGE COLOR] [FRAME COLOR]







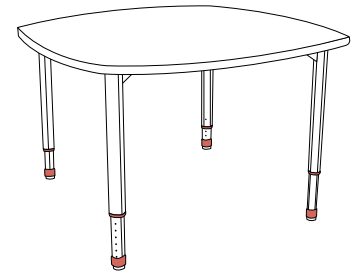







 BLACK (B)	 TITANIUM (T)	 WISDOM (Z)
 FLANNEL (F)	 COOL GRAY (O)	

STEP 4 PLASTIC ACCENTS

Use the letter next to the color name as the key code for **STEP 4**

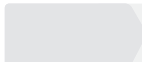

[FAMILY PART] - [WORK SURFACE] [EDGE COLOR] [FRAME COLOR] [PLASTIC ACCENT]

 FIRE TRUCK RED (A)	 VANILLA BLUE (E)	 PURPLE (P)	 BLUESCAPE (U)
 BLACK (B)	 GRASS GREEN (I)	 GREEN BEAN (Q)	 ORANGESICLE (X)
 MOD NAVY (C)	 GRAPHITE (M)	 GRAPLE (R)	 LELLO (Y)
 COFFEE (D)	 COOL GRAY (O)	 TANG (S)	 WISDOM (Z)

MODEL NUMBERS & PRODUCT SPECS

READ-IT TABLE RECTANGULAR TOP

Model #	Width (in)	Depth (in)	Height (in)	Weight (lbs)	Freight Class (Qty 1)
READ-IT-3060REC	60	30	24.5 - 35.5	130	85
READ-IT-3660REC	60	36	24.5 - 35.5	140	85
READ-IT-3672REC	72	36	24.5 - 35.5	150	85
READ-IT-4860REC	60	48	24.5 - 35.5	150	85

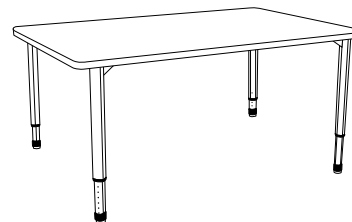

READ-IT TABLE SQUARE TOP

Model #	Width (in)	Depth (in)	Height (in)	Weight (lbs)	Freight Class (Qty 1)
READ-IT-4242S	42	42	24.5 - 35.5	150	85
READ-IT-4848S	48	48	24.5 - 35.5	150	85

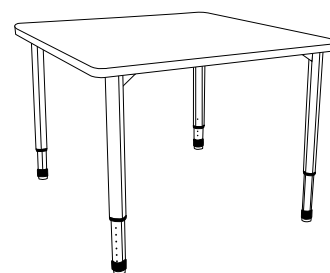

READ-IT TABLE TOMBSTONE TOP

Model #	Width (in)	Depth (in)	Height (in)	Weight (lbs)	Freight Class (Qty 1)
READ-IT-3060T	60	30	24.5 - 35.5	130	85
READ-IT-3660T	60	36	24.5 - 35.5	140	85
READ-IT-3672T	72	36	24.5 - 35.5	150	85
READ-IT-4242T	42	42	24.5 - 35.5	135	85
READ-IT-4848T	48	48	24.5 - 35.5	150	85
READ-IT-4860T	60	48	24.5 - 35.5	150	85

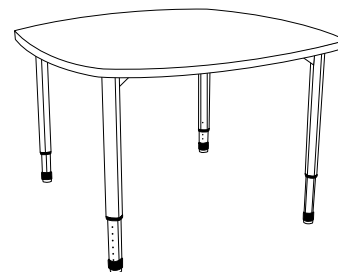

READ-IT TABLE ROUND TOP

Model #	Width (in)	Depth (in)	Height (in)	Weight (lbs)	Freight Class (Qty 1)
READ-IT-42R	42	42	24.5 - 35.5	135	85
READ-IT-48R	48	48	24.5 - 35.5	150	85
READ-IT-60R	60	60	24.5 - 35.5	195	85

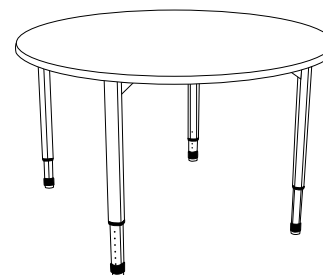

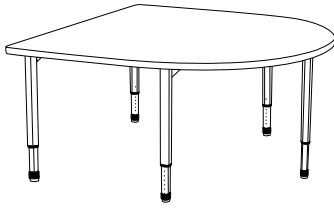

READ-IT TABLE BULLET TOP

Model #	Width (in)	Depth (in)	Height (in)	Weight (lbs)	Freight Class (Qty 1)
READ-IT-60BULLET	60	60	24.5 - 35.5	195	85

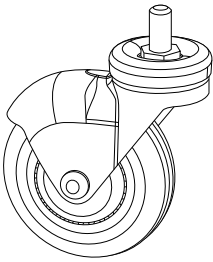

ACCESSORIES

Part #	Width (in)	Depth (in)	Height (in)	Weight (lbs)	Freight Class (Qty 1)
MOVE-ITX2	N/A	N/A	4	5	85
MOVE-ITX4	N/A	N/A	4	5	85
IT-AT-LEG-WIRE	3	1.5	18	5	85
PD-FLIP-USB	4.5 R	4.5 R	N/A	5	85



TEACH-IT TEACHER DESK & RETURN-IT

Paragon TEACH-IT Teacher Desks with RETURN-IT are designed & manufactured specifically for educational environments. They are flexible, functional, durable, & look great too!

FEATURES

○ SURFACE/EDGE

1 1/4" HPL with machine applied durable edge band.

○ HEIGHT

Height adjustable with fail safe 8 contact point bezel & set screws.

○ SHAPES



RECTANGLE TEACH-IT



TOMBSTONE TEACH-IT



RETURN-IT

○ COLOR OPTIONS

Five frame paint options with your choice of standard laminate colors for your top surface & a multiple accents to choose from.

○ TEACH-IT FRAME

Single post leg 14-gauge steel tube & leg lower is 16-gauge steel with perforated 1/4" holes every inch to allow for patented height adjustment bezel sleeve that contacts leg insert at 8 contact points. Molded plastic end cap. Perforated 16-gauge steel J-channel modesty panel/wire manager runs the length of the Teach-IT Desk.

○ RETURN-IT

Nests to either side of the tombstone top TEACH-IT Desk & can be attached with included ganging mechanism. Constructed of the same materials as the TEACH-IT Desk.



TEACH-IT Desk



TEACH-IT Desk with RETURN-IT

CONFIGURING A MODEL NUMBER

Refer to the Model Numbers & Product Specs section for a list of all family part model numbers in this product line. Use the chart below as a reference for how to properly specify this product.

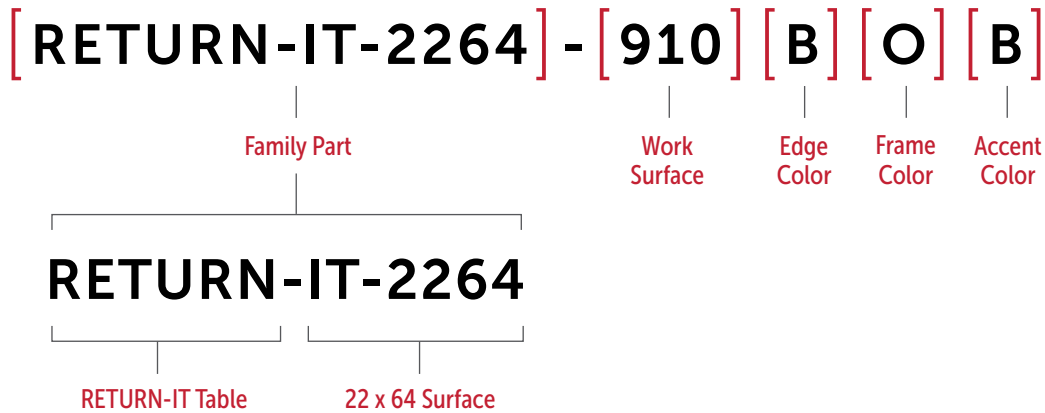
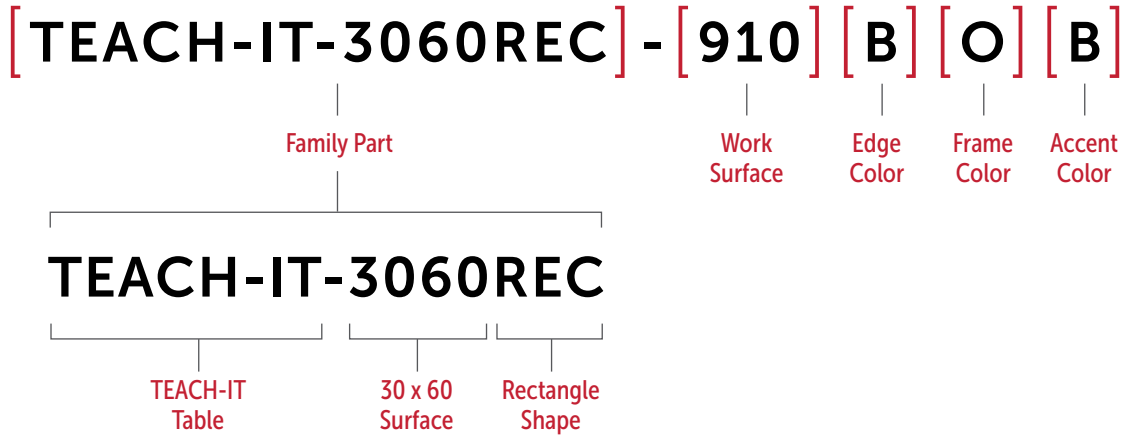

COLOR & FINISH OPTIONS

STEP 1 WORK SURFACE

Use the number next to the laminate name as the key code for **STEP 1**

[FAMILY PART] - [WORK SURFACE]

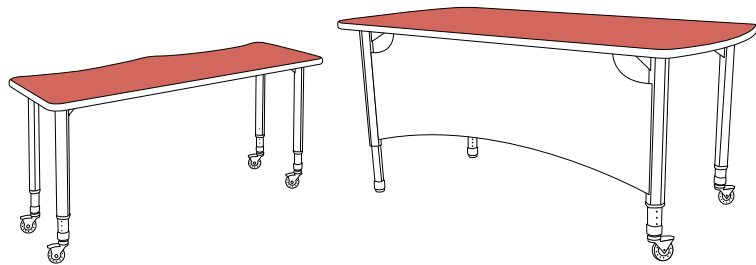

SOLID LAMINATE

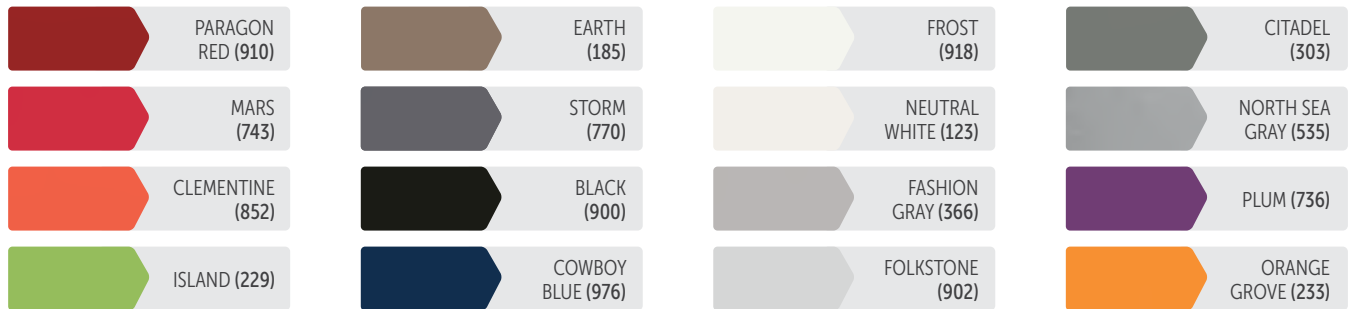

WHITEBOARD LAMINATE



WOOD GRAIN LAMINATE

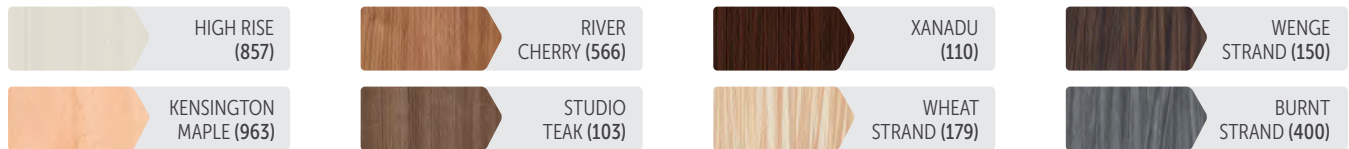

PATTERN LAMINATE



NEW COLORS



STEP 2
EDGE

Use the letter next to the color name as the key code for **STEP 2**

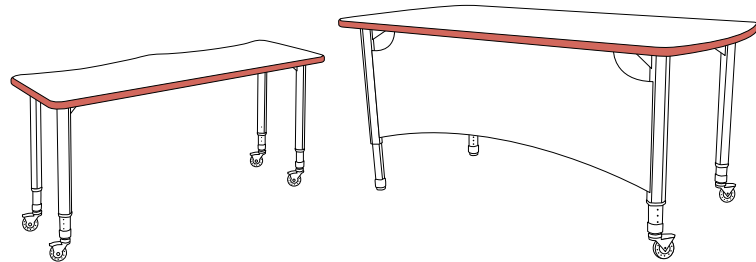

[FAMILY] - [WORK SURFACE] [EDGE COLOR]

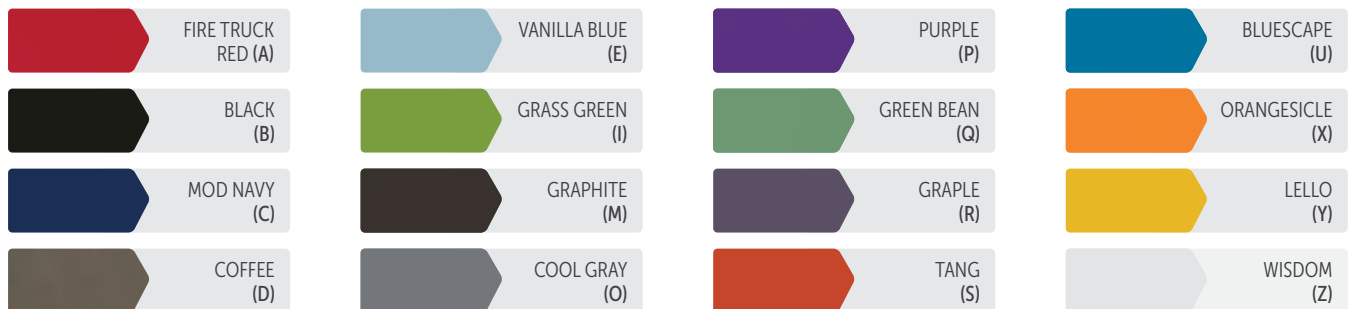

STEP 3 FRAME

Use the letter next to the color name as the key code for **STEP 3**

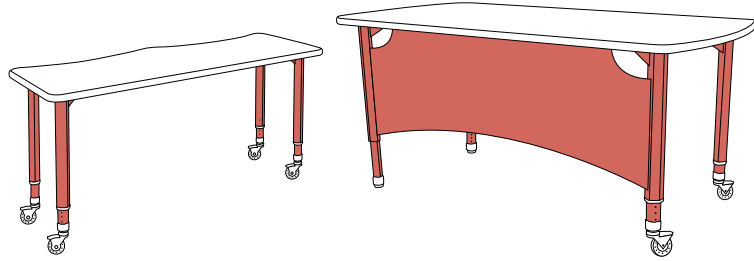

[FAMILY] - [WORK] [EDGE] [FRAME]
[PART] - [SURFACE] [COLOR] [COLOR]

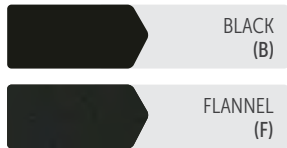

STEP 4 PLASTIC ACCENTS

Use the letter next to the color name as the key code for **STEP 4**

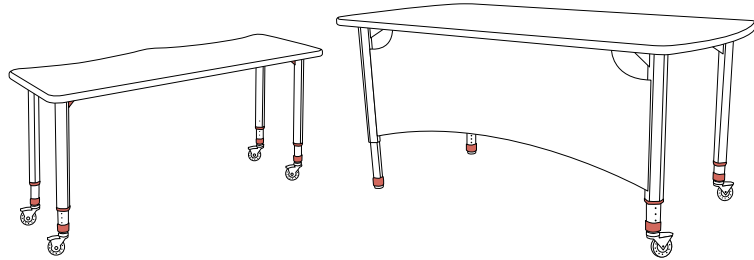

[FAMILY] - [WORK] [EDGE] [FRAME] [PLASTIC]
[PART] - [SURFACE] [COLOR] [COLOR] [ACCENT]

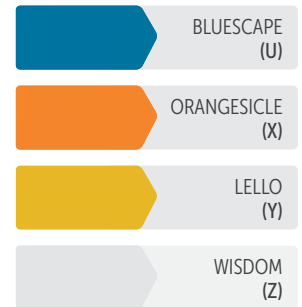
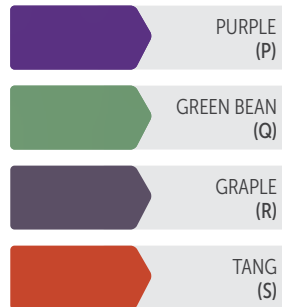
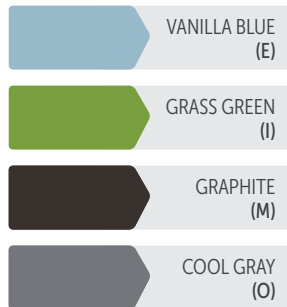

MODEL NUMBERS & PRODUCT SPECS

TEACH-IT TEACHER DESK

Model #	Width (in)	Depth (in)	Height (in)	Weight (lbs)	Freight Class (Qty 1)
TEACH-IT-3048REC	48	30	24.5 - 34.5	130	85
TEACH-IT-3048T	48	30	24.5 - 34.5	130	85
TEACH-IT-3060REC	60	30	24.5 - 34.5	145	85
TEACH-IT-3060T	60	30	24.5 - 34.5	145	85
TEACH-IT-3072REC	72	30	24.5 - 34.5	160	85
TEACH-IT-3072T	72	30	24.5 - 34.5	160	85

REC= Rectangle, T = Tombstone

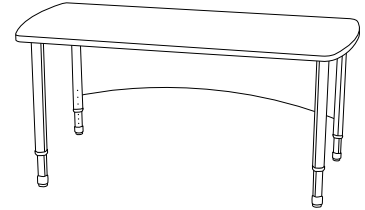

RETURN-IT RETURN FOR TOMBSTONE TOP TEACH-IT

Model #	Width (in)	Depth (in)	Height (in)	Weight (lbs)	Freight Class (Qty 1)
RETURN-IT-2264	64	22	28.5 - 39.5	130	85

*Comes standard with four casters

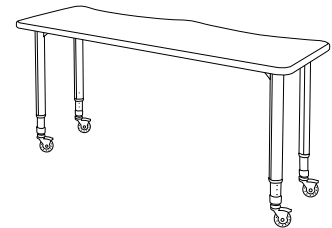

ACCESSORIES

Part #	Width (in)	Depth (in)	Height (in)	Weight (lbs)	Freight Class (Qty 1)
MOVE-ITX2	N/A	N/A	4	5	85
MOVE-ITX4	N/A	N/A	4	5	85
IT-AT-LEG-WIRE	3	1.5	18	5	85
PD-FLIP-USB	4.5 R	4.5 R	N/A	5	85
IT-MOD (MODESTY PANEL)	20.5	N/A	18	10	85
PEN-P	21	16	2	5	85

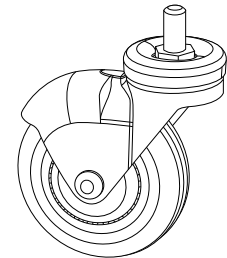

MODEL NUMBERS & PRODUCT SPECS

PD-FLIP PLACEMENT OPTIONS

TEACH-IT-3072

TEACH-IT-3060

TEACH-IT-3048

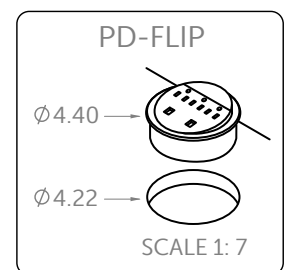
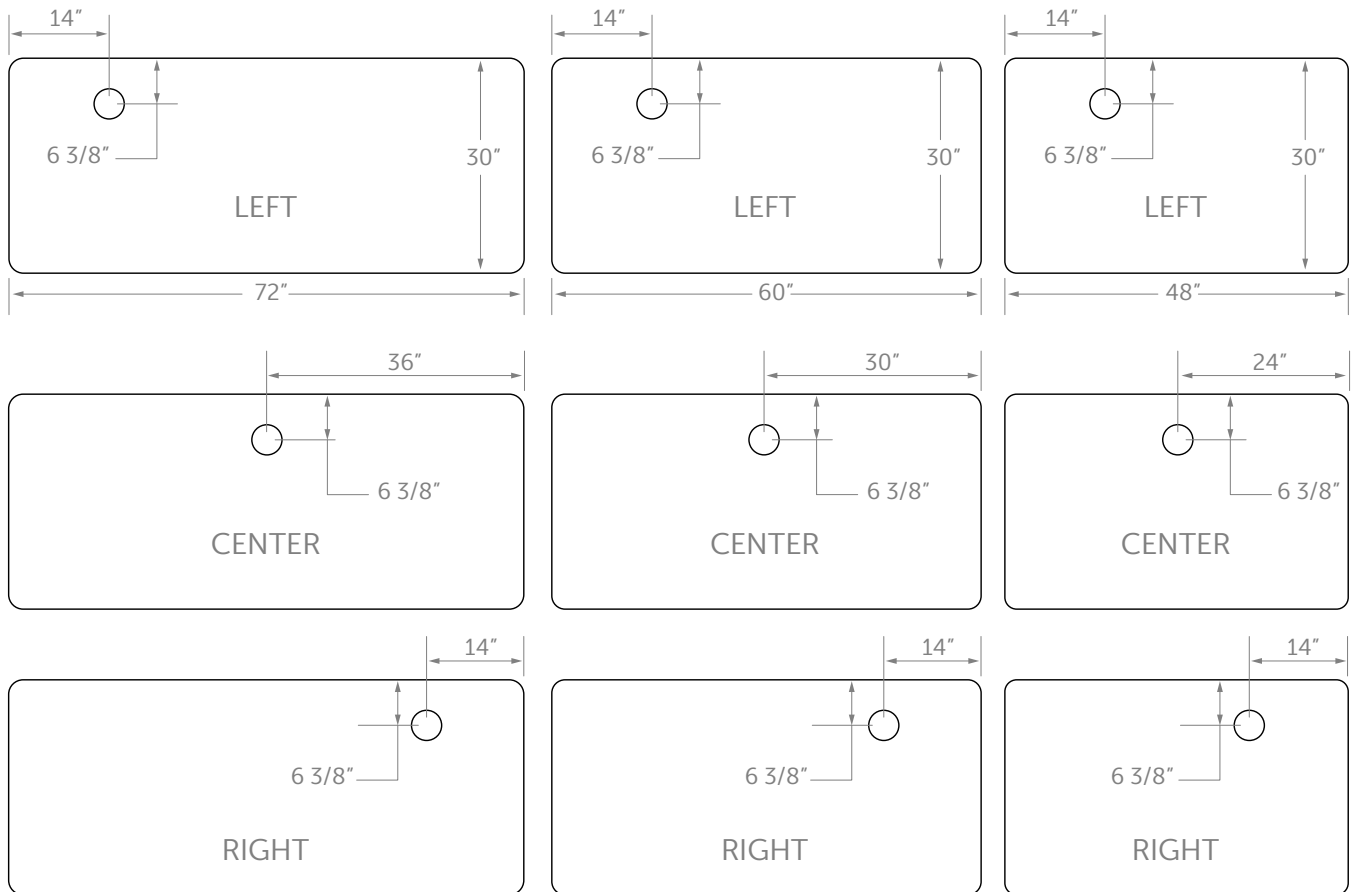



A&D CROSSFIT TEACHER LECTERN & DESK

The A&D® Crossfit Teacher Lectern offered with a right or left desk & an optional tablet tilt kickstand is perfect anywhere in the room. This desk features mobility, a locking door & adjustable shelves in the lectern with a right or left attached desk. The optional kickstand easily adjusts from a lectern to a projector stand.

THE DIFFERENCE

There's an innate difference when you specify Paragon Furniture. We're dedicated to designing safe & eco-friendly furniture that lasts. Our products are tested to meet & exceed ANSI/BIFMA certifications, we are committed to complying with MAS certified green criteria & our products are assembled in the U.S.A.



FEATURES

◊ SURFACE/EDGE

3/4" HPL with machine applied durable.

◊ FRAME

Sides are 3/4" thermally fused melamine with 3mm PVC edgeband. Desk modesty panel as well as the front & back of the lectern are made from 16-gauge perforated metal for a lighter weight & cohesive design in the A&D® line. The legs of the desk are our flattened oval adjustable single-post leg.

◊ CASTERS

Dualie casters are standard.



CONFIGURING A MODEL NUMBER

CONFIGURE TEACHER PODIUM

Refer to the Model Numbers & Product Specs section for a list of all family part model numbers in this product line. Use the chart below as a reference for how to properly specify this product.

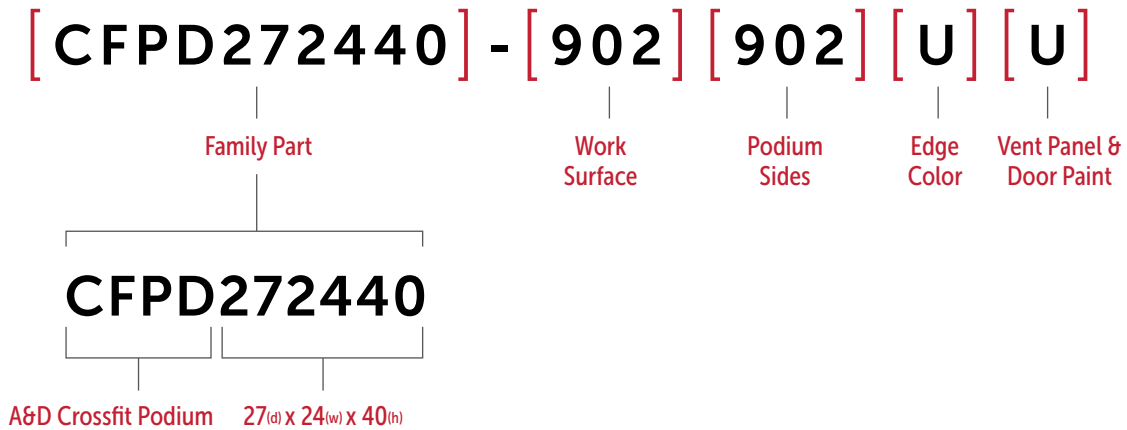

COLOR & FINISH OPTIONS

TEACHER PODIUM

STEP 1 WORK SURFACE

Use the number next to the laminate name as the key code for **STEP 1**

[FAMILY PART] - [WORK SURFACE]

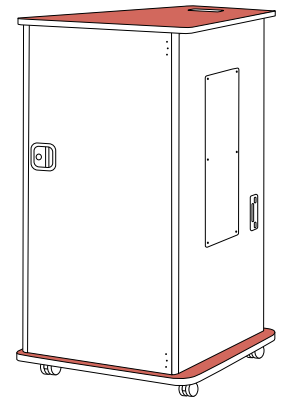

SOLID LAMINATE

PARAGON RED (910)	EARTH (185)	FROST (918)	CITADEL (303)
MARS (743)	STORM (770)	NEUTRAL WHITE (123)	NORTH SEA GRAY (535)
CLEMENTINE (852)	BLACK (900)	FASHION GRAY (366)	PLUM (736)
ISLAND (229)	COWBOY BLUE (976)	FOLKSTONE (902)	ORANGE GROVE (233)

WHITEBOARD LAMINATE



WOOD GRAIN LAMINATE

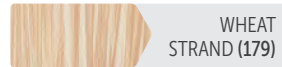
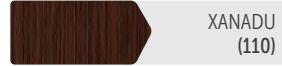

PATTERN LAMINATE

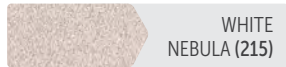

NEW COLORS

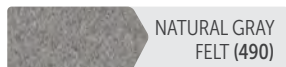
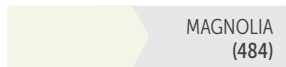

STEP 2 PODIUM SIDES

Use the letter next to the color name as the key code for **STEP 2**

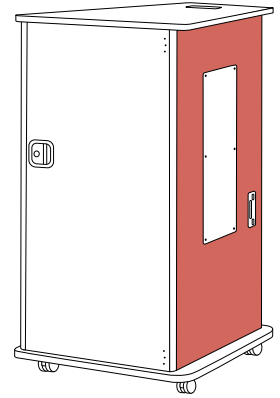

[FAMILY PART] - [WORK SURFACE] [PODIUM COLOR]



BLACK
(900)



FROST
(918)



FOLKSTONE
(902)



KENSINGTON
MAPLE (963)



STUDIO
TEAK (103)



RIVER
CHERRY (566)



XANADU
(110)

STEP 3 EDGE

Use the letter next to the color name as the key code for **STEP 3**

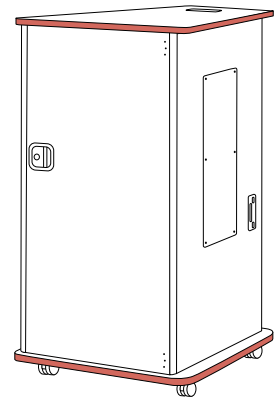

[FAMILY PART] - [WORK SURFACE] [PODIUM SIDES] [EDGE COLOR]



FIRE TRUCK
RED (A)



VANILLA BLUE
(E)



PURPLE
(P)



BLUESCAPE
(U)



BLACK
(B)



GRASS GREEN
(I)



GREEN BEAN
(Q)



ORANGESICLE
(X)



MOD NAVY
(C)



GRAPHITE
(M)



GRAPLE
(R)



LELLO
(Y)



COFFEE
(D)



COOL GRAY
(O)



TANG
(S)



WISDOM
(Z)

STEP 4 VENT PANEL & DOOR

Use the letter next to the color name as the key code for **STEP 4**

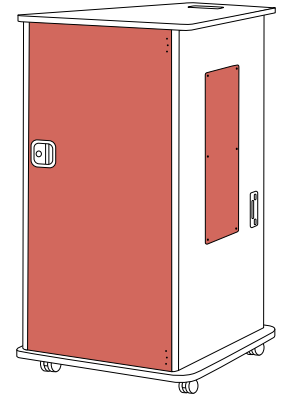

[FAMILY PART] - [WORK SURFACE] [PODIUM SIDES] [EDGE COLOR] [VENT PANEL & DOOR COLOR]

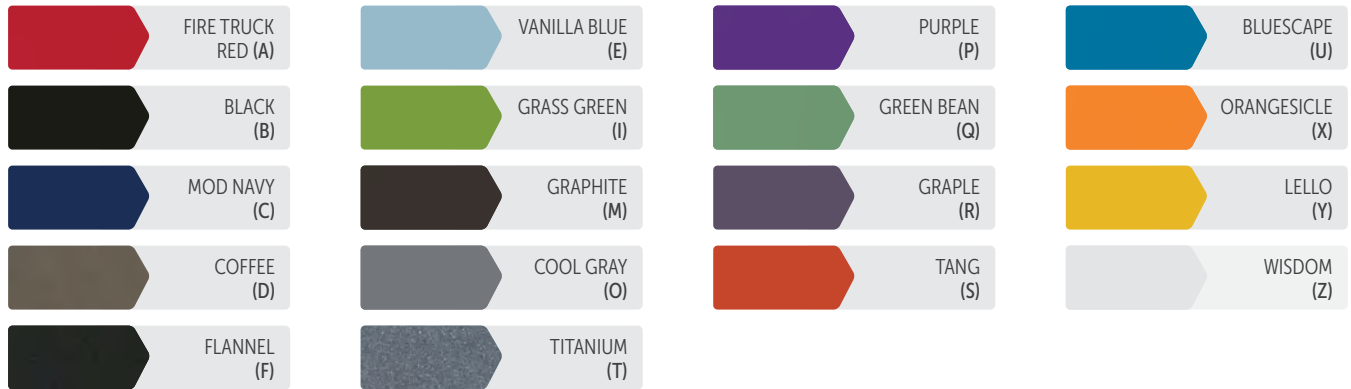

Vent Panel & Door are finished in the same color. Select one color from the palette above to represent those 2 items. Select one color from the palette below to finish kickstand. Black & Graphite paints are a textured paints.

STEP 5 KICKSTAND (OPTIONAL)

Use the letter next to the color name as the key code for **STEP 5**

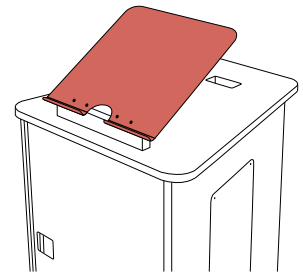

[FAMILY PART] - [WORK SURFACE] [PODIUM SIDES] [EDGE COLOR] [VENT PANEL & DOOR COLOR] [KICKSTAND]

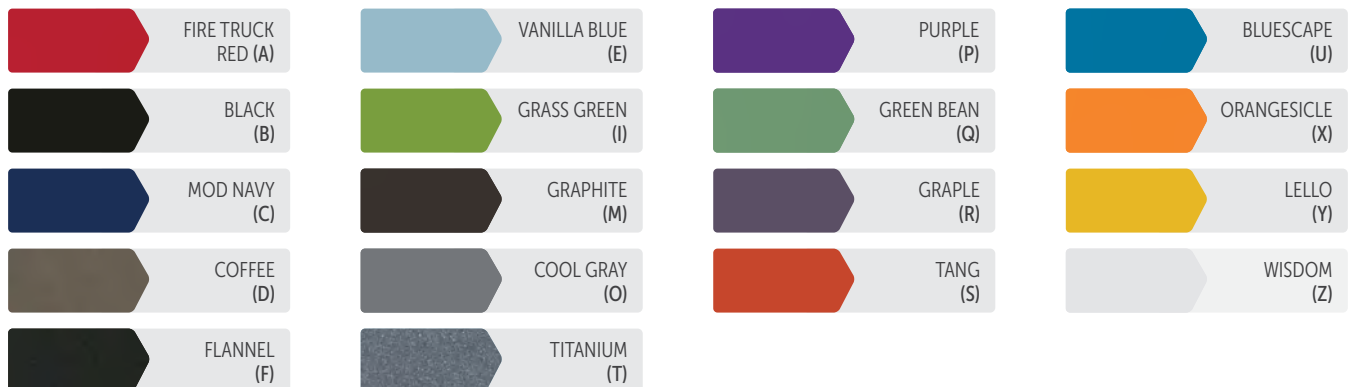

CONFIGURING A MODEL NUMBER

CONFIGURE TEACHER DESK

Refer to the Model Numbers & Product Specs section for a list of all family part model numbers in this product line. Use the chart below as a reference for how to properly specify this product.

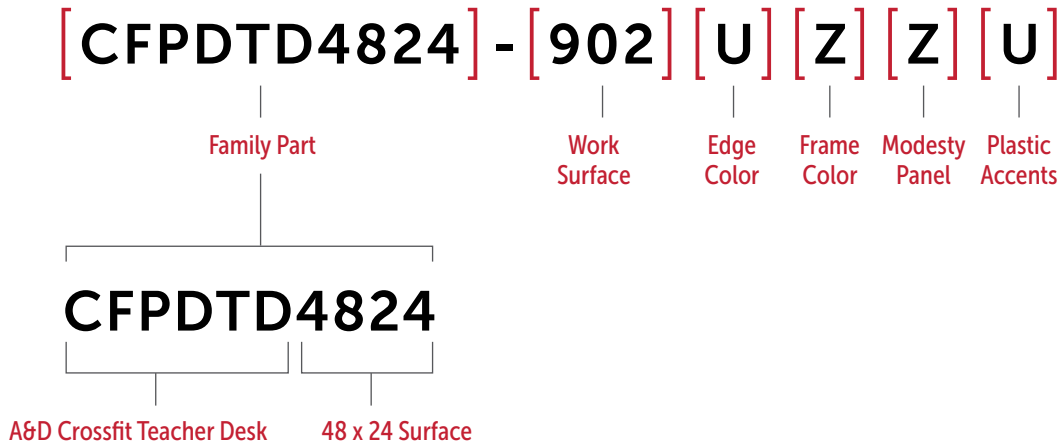

COLOR & FINISH OPTIONS

TEACHER DESK

STEP 1 WORK SURFACE

Use the number next to the laminate name as the key code for **STEP 1**

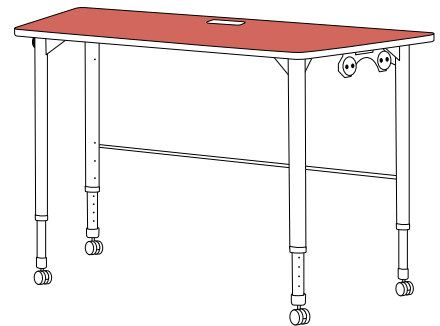

[FAMILY PART] - [WORK SURFACE]

SOLID LAMINATE

PARAGON RED (910)	EARTH (185)	FROST (918)	CITADEL (303)
MARS (743)	STORM (770)	NEUTRAL WHITE (123)	NORTH SEA GRAY (535)
CLEMENTINE (852)	BLACK (900)	FASHION GRAY (366)	PLUM (736)
ISLAND (229)	COWBOY BLUE (976)	FOLKSTONE (902)	ORANGE GROVE (233)

WHITEBOARD LAMINATE



WOOD GRAIN LAMINATE

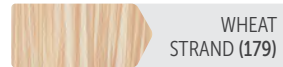
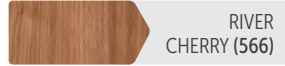

PATTERN LAMINATE

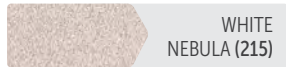

NEW COLORS

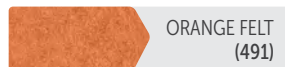
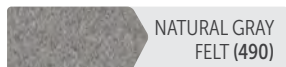





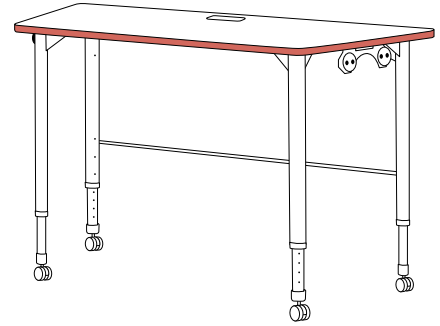









STEP 2 EDGE

Use the letter next to the color name as the key code for **STEP 2**

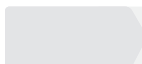

[FAMILY PART] - [WORK SURFACE] [EDGE COLOR]

 FIRE TRUCK RED (A)	 VANILLA BLUE (E)	 PURPLE (P)	 BLUESCAPE (U)
 BLACK (B)	 GRASS GREEN (I)	 GREEN BEAN (Q)	 ORANGESICLE (X)
 MOD NAVY (C)	 GRAPHITE (M)	 GRAPPLE (R)	 LELLO (Y)
 COFFEE (D)	 COOL GRAY (O)	 TANG (S)	 WISDOM (Z)

STEP 3 FRAME

Use the letter next to the color name as the key code for **STEP 3**

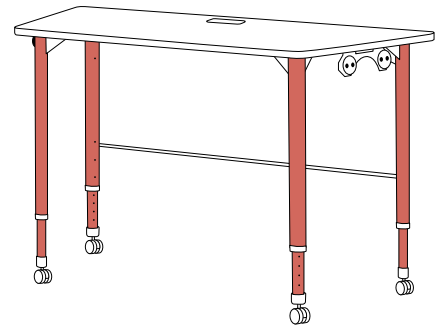

[FAMILY PART] - [WORK SURFACE] [EDGE COLOR] [FRAME COLOR]

 BLACK (B)	 TITANIUM (T)	 WISDOM (Z)
 FLANNEL (F)	 COOL GRAY (O)	

STEP 4 MODESTY PANEL

Use the letter next to the color name as the key code for **STEP 4**

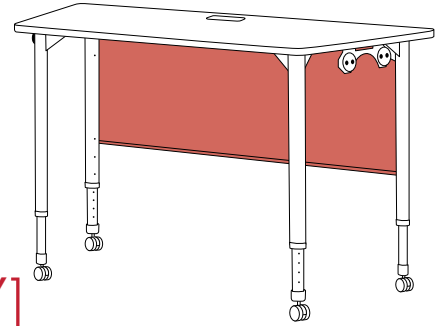

[FAMILY PART] - [WORK SURFACE] [EDGE COLOR] [FRAME COLOR] [**MODESTY PANEL**]

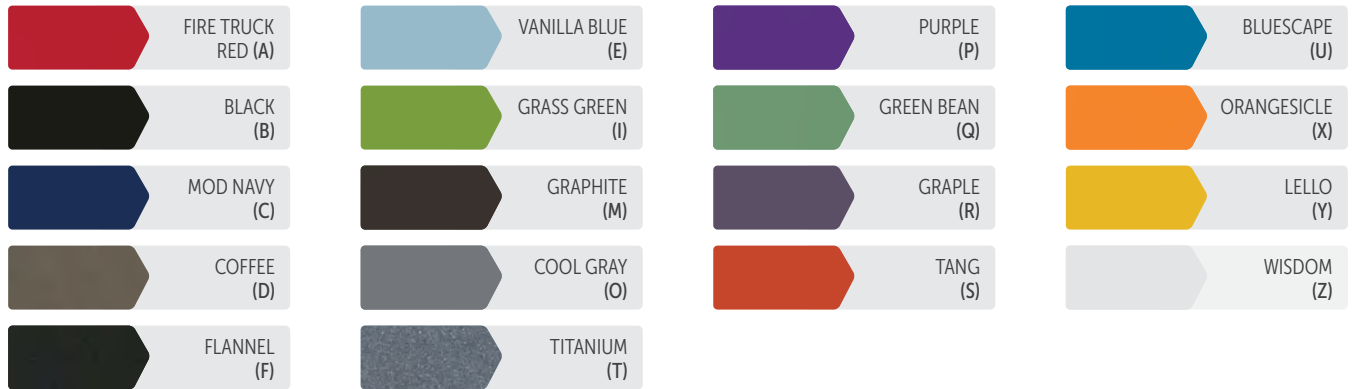

STEP 5 PLASTIC ACCENTS

Use the letter next to the color name as the key code for **STEP 5**

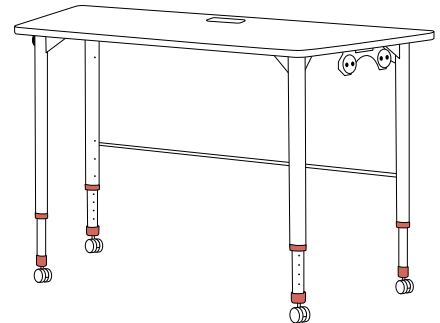

[FAMILY PART] - [WORK SURFACE] [EDGE COLOR] [FRAME COLOR] [MODESTY PANEL] [**PLASTIC ACCENT**]

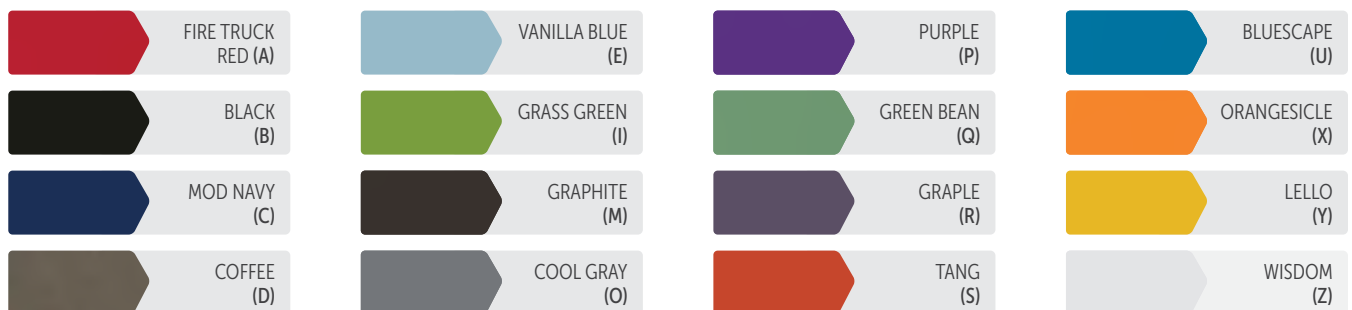

MODEL NUMBERS & PRODUCT SPECS

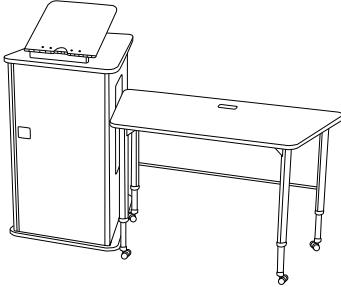

A&D® CROSSFIT AMBIDEXTROUS DESK & PODIUM

Model #	Width (in)	Depth (in)	Height (in)	Weight (lbs)	Freight Class (Qty 1)
CFPD272440 (Podium without Kickstand)	24	27	40	60	125
CFPD272440K (Podium with Kickstand)	24	30	40	60	125
CFPDTD4824 (Desk)	48	24	24 - 34	50	85

A&D® CROSSFIT TEACHER LECTERN ACCESSORIES

Model #	Width (in)	Depth (in)	Height (in)	Weight (lbs)	Freight Class (Qty 1)
PEN-P	21	16	2	5	85
PD-FLIP-USB	4.5 R	4.5 R	N/A	5	85

PD-FLIP PLACEMENT OPTIONS

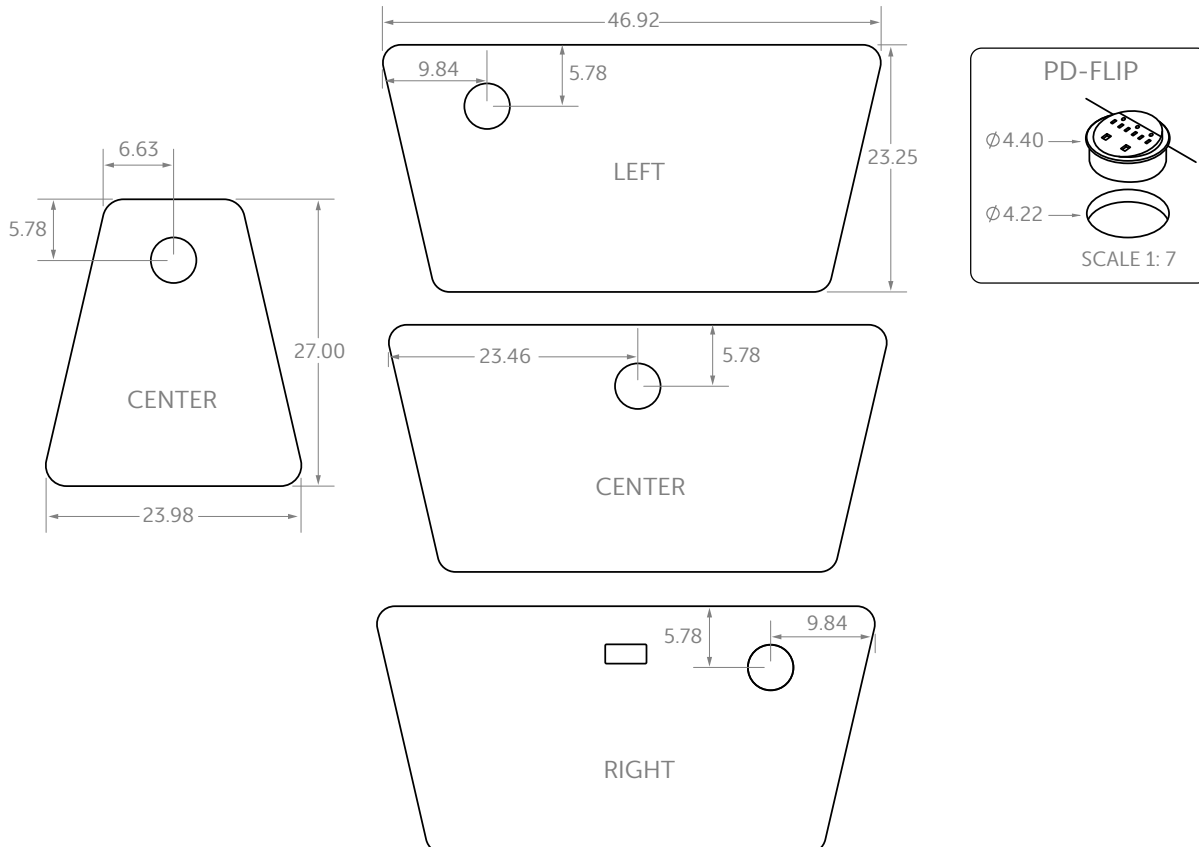







CHAIRS & SEATING



EMOJI™ SEATING

EMOJI™ seating helps create a delightful experience for children & a refined, performance driven experience for adults. Each piece is designed to support us in how we move & find comfort at various ages as well as how we evolve from seeking playfulness to focus. Four sizes cover all ages & hold characteristics specific to the physical & skeletal needs of each.

FEATURES

◻ SHELL & FRAME

Seats are constructed using a semi gas-assisted process resulting in a lightweight, one-piece, plastic shell. Attached to the plastic shell is a welded steel, powder-coated, 1" round tube frame. 4 leg chair frames are 14-gauge, 0.074 thick steel. Cantilever chair frames are 12-gauge, 0.120 thick steel.

◻ RUBBER BUMPERS

The underside of the shell is designed with rubber bumpers to protect chairs & surfaces from being scratched when stacked.

◻ TWO BASE OPTIONS

Available in two base options: 4 leg & cantilever.

◻ STACKING

Chairs stack up to five to allow for easy, compact storage.

◻ COLORS

Available in 16 plastic & 5 frame paint colors.

◻ GLIDES OR CASTERS

4 leg seating is offered in glides or casters. Glide bottom material should be selected based on flooring type.

◻ A CHAIR FOR EVERY AGE

At every age, EMOJI™ Seating is designed to support us. The support structure of the adult chair more closely mimics the grown-up spine & pelvis.

◻ CHAIR WEIGHT CAPACITY

Our Chairs are tested to meet Business and Institutional Furniture Manufacturers Association (BIFMA) standards the industry benchmark for furniture safety, durability, and structural performance. This testing helps ensure the chairs perform as intended in demanding environments such as classrooms and other educational settings when used appropriately.

SENSORY ERGONOMICS

The human perception of comfort is affected by every aspect of our environment. EMOJI™ features & details were designed to generate a sensory response.

◻ TEXTURE

We see with our hands. This means that what we touch & feel has a major effect on how we respond to things. Cold, rough, & sharp textures are all interpreted as uninviting conditions. EMOJI™ has textured zones to hold you firmly in your seat while you're sitting down & to keep rough areas away from where you touch. The human brain also responds exceptionally well when presented with a single, obvious place or method to grab, hold, or move something. The EMOJI™ handle is a critical gesture of empathy to the human brain.

◻ COLOR CONNECTION

Color can be used scientifically in architecture to promote certain types of behaviors or emotions in an environment. The human eye & brain can interpret color & generate

an emotional or physical response based on the color itself. Bright primary colors, neons, & bright multicolored patterns will generate excitement, increase awareness of overall surroundings, & heighten the mind's production of chemicals that increase energy & activity. Muted colors & monochromatic environments have the opposite effect. They trigger the release of chemicals in the brain that will promote relaxation & calm.

◻ SOUND

Sound is an unlikely, but major source of disruption. Additionally, ambient noise is constantly requiring the ears & brain to interpret sound, which leads to fatigue by the end of the day. EMOJI™ uses rubber bumpers & quiet casters to minimize distraction.

CHAIR SIZE GUIDE

Seat Height	12"	14"	16"	18"
Pre-K	X			
Kindergarten	X	X		
1 st Grade		X		
2 nd Grade			X	
3 rd Grade			X	
4 th Grade			X	
5 th Grade				X
6 th - 12 th Grade				X



CONFIGURING A MODEL NUMBER

Refer to the Model Numbers & Product Specs section for a list of all family part model numbers in this product line. Use the chart below as a reference for how to properly specify this product.

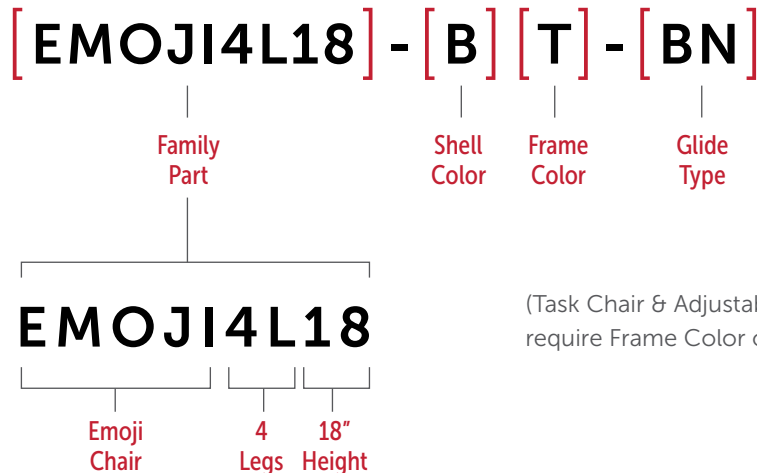







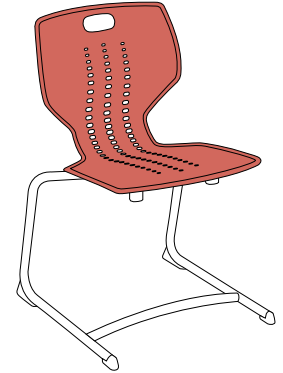







COLOR & FINISH OPTIONS

STEP 1 SHELL COLOR

Use the letter next to the Family part as the key code for **STEP 1**

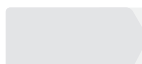

[FAMILY PART] - [SHELL COLOR]

 FIRE TRUCK RED (A)	 VANILLA BLUE (E)	 PURPLE (P)	 BLUESCAPE (U)
 BLACK (B)	 GRASS GREEN (I)	 GREEN BEAN (Q)	 ORANGESICLE (X)
 MOD NAVY (C)	 GRAPHITE (M)	 GRAPLE (R)	 LELLO (Y)
 COFFEE (D)	 COOL GRAY (O)	 TANG (S)	 WISDOM (Z)

STEP 2 FRAME

Choose your frame color. Refer to the letter next to the color name for **STEP 2**

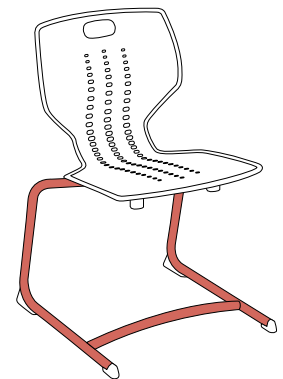

[FAMILY PART] - [SHELL COLOR] [FRAME COLOR]

 BLACK (B)	 TITANIUM (T)	 WISDOM (Z)
 FLANNEL (F)	 COOL GRAY (O)	

CYCLE™ SERIES COLOR & FINISH OPTIONS



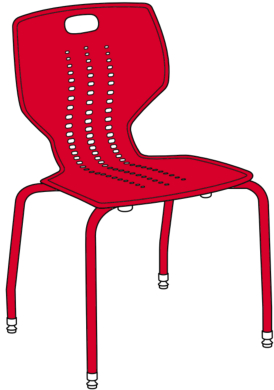

Select one of the color combinations for **STEP 1**

STEP 1 SHELL & FRAME COLOR













[FAMILY PART] - [SHELL & FRAME COLOR]

SHELL COLOR

 PEBBLE (CP)	 AMBER (CA)	 CLAY (CC)	 FERN (CF)	 LAKE (CL)
+	+	+	+	+

FRAME COLOR

 PEBBLE (CP)	 AMBER (CA)	 CLAY (CC)	 FERN (CF)	 LAKE (CL)
OR	OR	OR	OR	OR
 ONYX (CO)	 ONYX (CO)	 ONYX (CO)	 ONYX (CO)	 ONYX (CO)

STEP 3 GLIDE

Chairs come standard with nylon glides. For metal glides, add BM to the end of the model number. For felt glides, add BF to the end of the model number. If not specified, chair will have nylon glides.

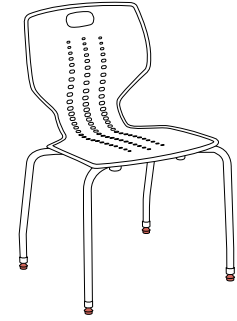

[FAMILY] - [SHELL] [FRAME] - [GLIDE]
[PART] [COLOR] [COLOR] [TYPE]

	Carpet Floor	Hardwood Floor	Bamboo Floor	Rubber Floor	Concrete Floor	Tile Floor	VCT Floor	Laminate Floor
Nylon Glide	X			X	X	X	X	X
Metal Glide (BM)	X							
Felt Glide (BF)		X	X			X	X	X

MODEL NUMBERS & PRODUCT SPECS

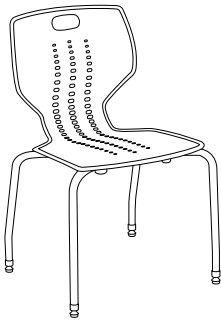

EMOJI™ 4-LEG CHAIR

Model #	Seat Height (in)	Width (in)	Depth (in)	Weight Capacity (lbs)	Overall Height (in)	Weight (lbs)	Freight Class (Qty 1)
EMOJI4L12	12.7	14.9	13.7	175	22.6	10	200
EMOJI4L14	14.5	17.6	15.9	175	26.9	10	200
EMOJI4L16	16.5	17.7	16.3	230	28.9	10	200
EMOJI4L18	18.4	20.4	19.5	300	33.3	15	200

*Add **BM** for Metal glides or **BF** for Felt glides. No price increase. Ex: EMOJI4L12BM / EMOJI4L12BF

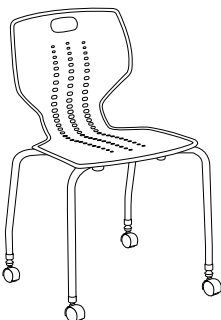

EMOJI™ 4-LEG CHAIR WITH CASTERS

Model #	Seat Height (in)	Width (in)	Depth (in)	Weight Capacity (lbs)	Overall Height (in)	Weight (lbs)	Freight Class (Qty 1)
EMOJI4L12C	12.8	15.4	13.7	175	22.7	10	200
EMOJI4L14C	14.6	18.1	15.9	175	27	10	200
EMOJI4L16C	16.6	18.2	16.3	230	29	10	200
EMOJI4L18C	18.3	20.9	19.5	300	33.2	15	200

EMOJI™ CANTILEVER CHAIR

Model #	Seat Height (in)	Width (in)	Depth (in)	Weight Capacity (lbs)	Overall Height (in)	Weight (lbs)	Freight Class (Qty 1)
EMOJICA14	14.3	18.1	17.9	175	25.8	10	200
EMOJICA16	16.7	18.1	17.9	230	28.2	15	200
EMOJICA18	18.3	20.4	21.4	300	31.4	20	200

*Add **BM** for Metal glides or **BF** for Felt glides. No price increase. Ex: EMOJICA12**BM** / EMOJICA12**BF**

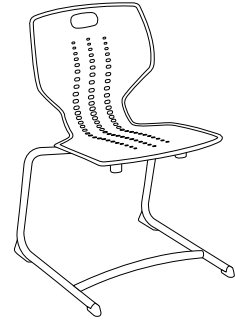

EMOJI™ 4-LEG STOOL

Model #	Seat Height (in)	Width (in)	Depth (in)	Weight Capacity (lbs)	Overall Height (in)	Weight (lbs)	Freight Class (Qty 1)
EMOJI4LST25	25.8	18.2	19.5	300	39.8	20	200
EMOJI4LST30	30.7	18.2	21.2	300	45.6	20	200

*Add **BM** for Metal glides or **BF** for Felt glides. No price increase. Ex: EMOJI4LST**BM** / EMOJI4LST**BF**

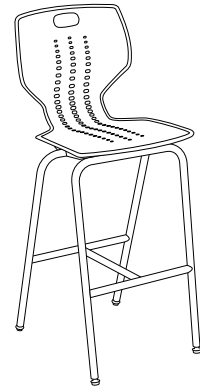

EMOJI™ TASK CHAIR

Model #	Seat Height (in)	Width (in)	Depth (in)	Weight Capacity (lbs)	Overall Height (in)	Weight (lbs)	Freight Class (Qty 1)
EMOJICHRA	17.5 - 23.5	23.9	23.6	300	32.4 - 38.4	20	200

*Available with black frame only

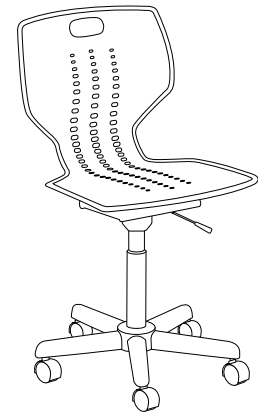

EMOJI™ LAB STOOL

Model #	Seat Height (in)	Width (in)	Depth (in)	Weight Capacity (lbs)	Overall Height (in)	Weight (lbs)	Freight Class (Qty 1)
EMOJISTLA	23 - 33	23.9	23.6	300	37.9 - 47.9	20	200

*Available with black frame only

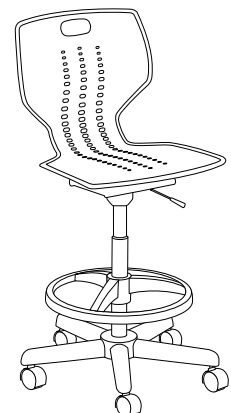



READY[®] CHAIRS & STOOLS

Available in 6 different base styles, & multiple sizes. Ready Chairs are ideal for classrooms, maker spaces, libraries & for students & teachers alike.

HOW TO SPECIFY

FRAME

Constructed with 1" diameter 11-gauge tubular steel, supported by 14-gauge steel brackets. 360° contact points between underside steel frame & shell with steel rivets for advanced durability. Frame finished with electrostatically charged powder coating.

SHELL

Gas-assist injection-molded polypropylene one-piece shell with deep chamfered edge & flexible back. Chair back allows for 18° of pressure flex, is smooth without ribs, & has single opening contoured handle cut-out. Chair seat includes ComfortSlope™ chamfered edge & allows for convenient 4-way sit. Available in 16 colors.

GLIDES

4 leg chairs, stools, & cantilever chairs all come standard with steel-encased nylon-base glides for safe & easy movement. These style chairs can also be specified with felt or metal base glides depending on flooring material.

CERTIFICATIONS

- ANSI/BIFMA X6.1 Safety & performance standards for educational seating.
- MAS certified green.
- LEED for schools CHPS EQ 2.3.5 credit.



CHAIR SIZE GUIDE

Seat Height	14"	16"	18"
1 st Grade	X		
2 nd Grade	X	X	
3 rd Grade		X	
4 th Grade		X	
5 th Grade			X
6 th - 12 th Grade			X



Cantilever



Caster



Cafe Stool



Lab Stool



Task

CONFIGURING A MODEL NUMBER

Refer to the Model Numbers & Product Specs section for a list of all family part model numbers in this product line. Use the chart below as a reference for how to properly specify this product.

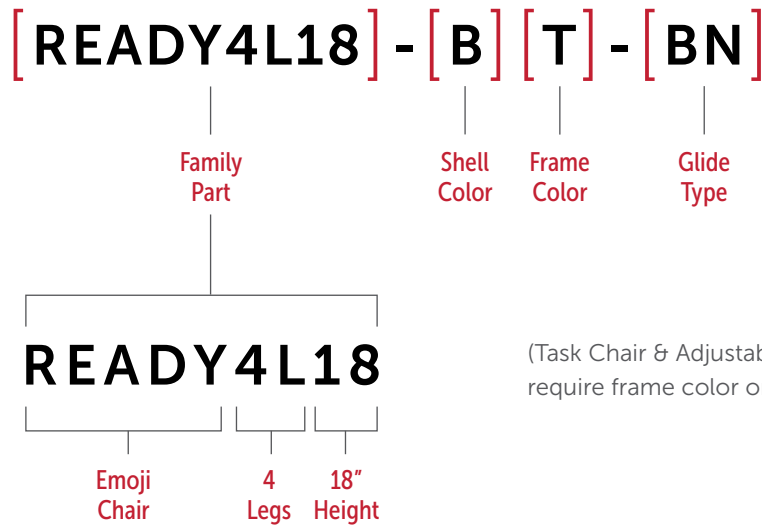

(Task Chair & Adjustable Lab Stool do not require frame color or glide type)

COLOR & FINISH OPTIONS

STEP 1 SHELL COLOR

Use the letter next to the Family part as the key code for **STEP 1**

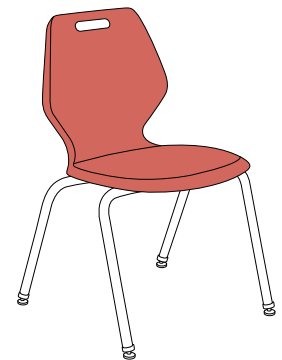

[**FAMILY PART**] - [**SHELL COLOR**]

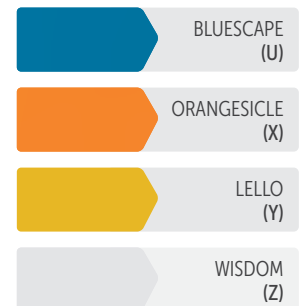
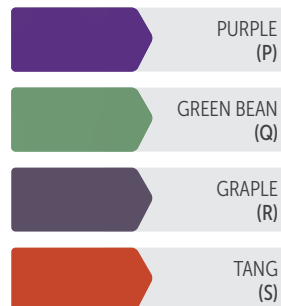
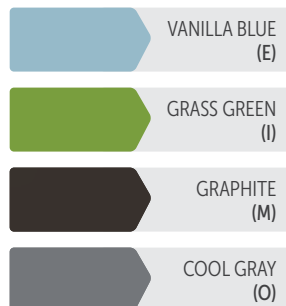
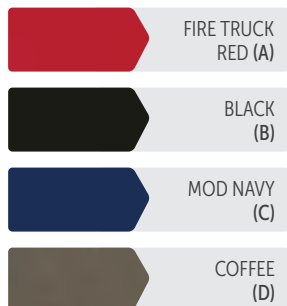

STEP 2 FRAME

Choose your frame color. Refer to the letter next to the color name for **STEP 2**



[FAMILY PART] - [SHELL COLOR] [FRAME COLOR]



BLACK
(B)



TITANIUM
(T)



WISDOM
(Z)



FLANNEL
(F)



COOL GRAY
(O)

CYCLE™ SERIES COLOR & FINISH OPTIONS

Select one of the color combinations for **STEP 1**

STEP 1 SHELL & FRAME COLOR

[FAMILY PART] - [SHELL & FRAME COLOR]

SHELL COLOR



+

+

+

+

+

FRAME COLOR



OR

OR

OR

OR

OR



ONYX
(CO)



ONYX
(CO)



ONYX
(CO)



ONYX
(CO)



ONYX
(CO)

STEP 3 GLIDE

Chairs come standard with nylon glides. For metal glides, add BM to the end of the model number. For felt glides, add BF to the end of the model number. If not specified, chair will have nylon glides.

[FAMILY] - [SHELL] [FRAME] - [GLIDE]
[PART] - [COLOR] [COLOR] - [TYPE]

	Carpet Floor	Hardwood Floor	Bamboo Floor	Rubber Floor	Concrete Floor	Tile Floor	VCT Floor	Laminate Floor
Nylon Glide	X			X	X	X	X	
Metal Glide (BM)	X							
Felt Glide (BF)		X	X			X	X	X

CHAIR WEIGHT CAPACITY

Our Chairs are tested to meet Business and Institutional Furniture Manufacturers Association (BIFMA) standards the industry benchmark for furniture safety, durability, and structural performance. This testing helps ensure the chairs perform as intended in demanding environments such as classrooms and other educational settings when used appropriately.

MODEL NUMBERS & PRODUCT SPECS

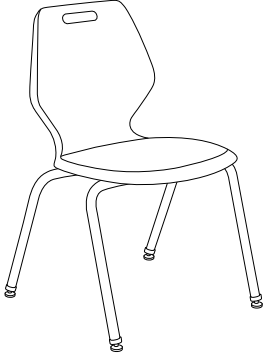

READY® 4-LEG CHAIR

Model #	Seat Height (in)	Width (in)	Depth (in)	Weight Capacity (lbs)	Overall Height (in)	Weight (lbs)	Freight Class (Qty 1)
READY4L14	14.2	18.1	16.4	175	25.6	10	200
READY4L16	16.2	18.1	18	230	27.6	10	200
READY4L18	18.1	20.7	19.4	330	31.7	15	200

*Add **BM** for Metal glides or **BF** for Felt glides. No price increase. Ex: READY4L14**BM** / READY4L14**BF**

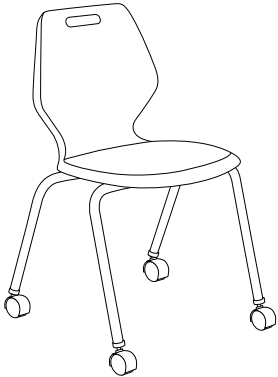

READY® 4-LEG WITH CASTERS

Model #	Seat Height (in)	Width (in)	Depth (in)	Weight Capacity (lbs)	Overall Height (in)	Weight (lbs)	Freight Class (Qty 1)
READY4L14C	14.3	18.3	15.9	175	25.7	10	200
READY4L16C	16.1	18.3	17.1	230	27.5	10	200
READY4L18C	18	20.9	18.5	300	31.6	15	200

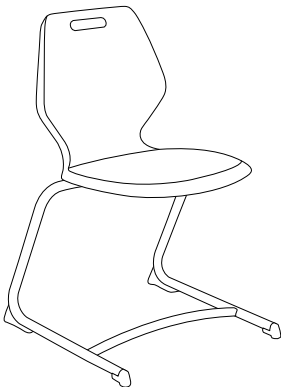

READY® CANTILEVER CHAIR

Model #	Seat Height (in)	Width (in)	Depth (in)	Weight Capacity (lbs)	Overall Height (in)	Weight (lbs)	Freight Class (Qty 1)
READYCA14	14	17.9	14.6	175	25.4	10	200
READYCA16	16	17.9	14.6	230	27.4	15	200
READYCA18	18	20.4	18.4	300	31.6	20	200

*Add **BM** for Metal glides or **BF** for Felt glides. No price increase. Ex: READYCA14**BM** / READYCA14**BF**

READY® 4-LEG STOOL

Model #	Seat Height (in)	Width (in)	Depth (in)	Weight Capacity (lbs)	Overall Height (in)	Weight (lbs)	Freight Class (Qty 1)
READY4LST25	25	18.2	19.1	300	38.6	20	200
READY4LST30	30.4	18.2	20.9	300	44	20	200

*Add **BM** for Metal glides or **BF** for Felt glides. No price increase. Ex: READY4LST25BM / READY4LST25BF

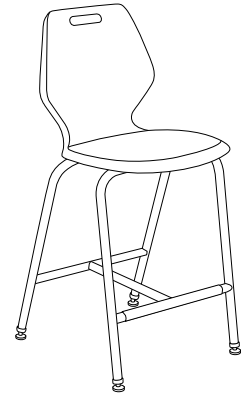

READY® TASK CHAIR

Model #	Seat Height (in)	Width (in)	Depth (in)	Weight Capacity (lbs)	Overall Height (in)	Weight (lbs)	Freight Class (Qty 1)
READYCHRA	17 - 23	24	24	300	30.6 - 36.6	20	200

*Available with black frame only

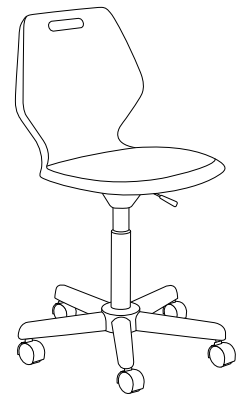

READY® LAB STOOL

Model #	Seat Height (in)	Width (in)	Depth (in)	Weight Capacity (lbs)	Overall Height (in)	Weight (lbs)	Freight Class (Qty 1)
READYSTLA	22.5 - 32.5	24	24	300	36.2 - 46.2	20	200

*Available with black frame only

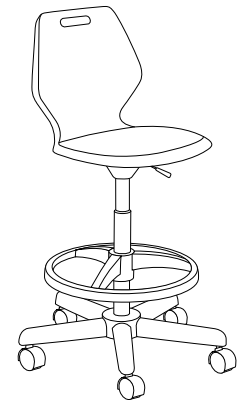



OINGO ADJUSTABLE PIVOT STOOL

Oingo is a pneumatic height adjustable stool that can pivot, tilt, swivel & bounce - all while keeping the base flat on the floor. The high-density foam seat can be upholstered in numerous colors that you'll find on the next pages.

FEATURES

MOVEMENT

The OINGO stool is height adjustable with the push of a button & can pivot, tilt, swivel, & bounce while the base stays solid & flat on the floor.

SIZES

OINGO is available in 2 adjustable height options.

- **OINGO 30:**
Adjusts from 22.5" – 30" H
- **OINGO 21:**
Adjusts from 16.5" – 20.5" H

HIGH-DENSITY FOAM SEAT

The seat cushion is constructed of high-density 75lb ILD foam that is designed to be comfortable but durable enough to withstand rigorous use.

TEXTILE OPTIONS

The OINGO seat can be upholstered in numerous graded-in textiles, as well as COM (Customer's Own Material). All Oingo seats come standard with neutral color stitching.

SOLID BASE

The base has 8 contact points that touch the ground, keeping it firm & flat while the rest of the stool pivots & moves freely.

ANSI/BIFMA CERTIFIED

OINGO has been put through extensive safety & durability testing & is certified to ANSI/BIFMA standards.



CONFIGURING A MODEL NUMBER

Choose your family part. In this example, we used part **OINGO30**. The structure of this new part number can be broken up with parenthesis like this:

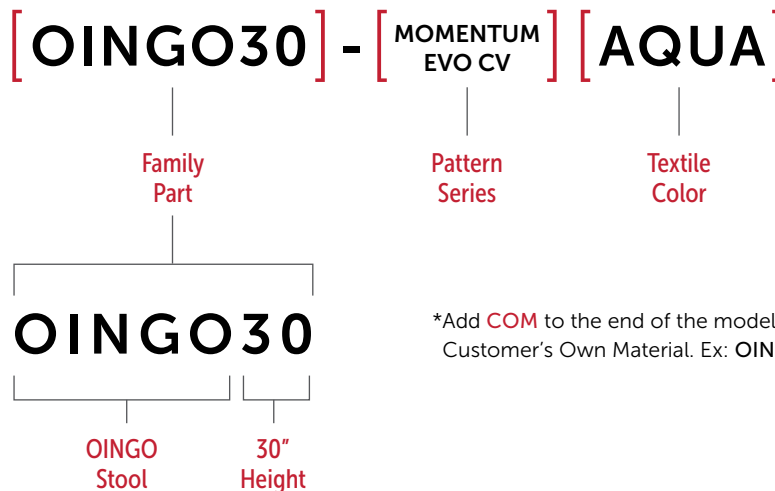

*Add **COM** to the end of the model number if specifying Customer's Own Material. Ex: **OINGO30-COM**

COLOR & FINISH OPTIONS

STEP 1
PATTERN SERIES
TEXTILE COLOR



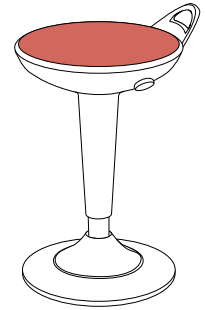





Use the name of the textile color as the key code for **STEP 1**









[**FAMILY PART**] - [**PATTERN SERIES**] - [**TEXTILE COLOR**]

(Please provide pattern & color name)

MAYER QUATTRO PATTERN SERIES

 CHALK	 MALLARD	 LEAF	 MIDNIGHT BLUE
 SKYWAY BLUE	 LAGUNA	 VIOLET	 HIBISCUS

CF STINSON LARA PATTERN SERIES

 TAMALE	 HEARTH	 VELVET	 EVENING
 MIDBLUE	 SALSA	 STONE	

MOMENTUM EVO CV PATTERN SERIES

 AQUA	 ZEST	 BLUET	 RAM
 CYAN	 TANGELO	 BLUESTAR	 JETTY
 BREEZE	 SCARLET	 SKYLAR	 CHAMBRAY
 KELLY	 CAROB	 PERI	 ONYX
 MIST	 PEWTER	 REGAL	

MOMENTUM TRIBECA CV PATTERN SERIES



MOMENTUM VANGUARD CV PATTERN SERIES



SPRADLING EDGELINE PATTERN SERIES

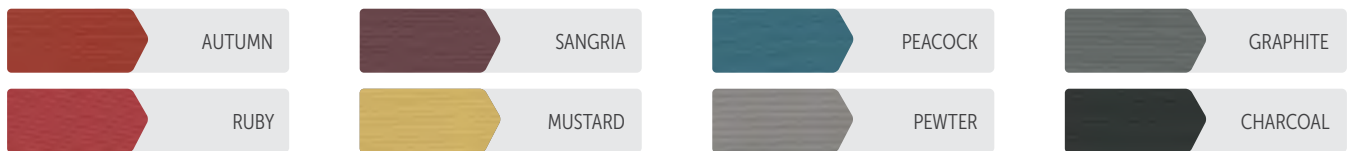

SPRADLING SILVERTEX PATTERN SERIES

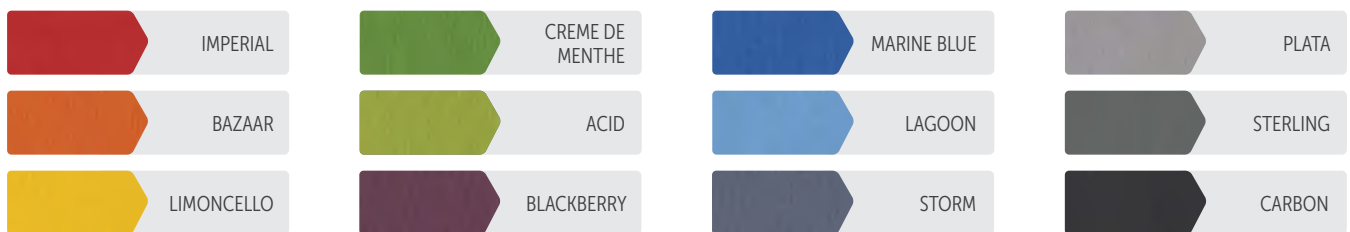

GRADED-IN PROGRAM

Soft seating is also available in hundreds of additional textiles through our graded-in program.

Scan the QR code or visit paragoninc.com/textiles for details.

If you have a custom fabric you'd like to use, we also offer a COM option. Contact us for additional information.



MODEL NUMBERS & PRODUCT SPECS

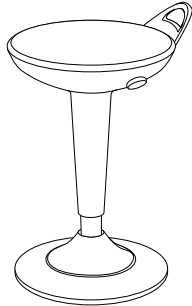

OINGO 30" ADJUSTABLE PIVOT STOOL

Model #	Width (in)	Depth (in)	Height (in)	Weight Capacity (lbs)	Weight (lbs)	Freight Class (Qty.1)
OINGO30	15.5	17	22.5 - 30	300	17	85



OINGO 21" ADJUSTABLE PIVOT STOOL

Model #	Width (in)	Depth (in)	Height (in)	Weight Capacity (lbs)	Weight (lbs)	Freight Class (Qty.1)
OINGO21	15.5	17	16.5 - 20.5	300	16	85



BLENDER® FOAM SOFT SEATING

Entice students to come in and take a seat with our BLENDER® Foam Soft Seating. Designed to blend in with our library & classroom offerings, the designs are highly configurable in groups or as stand alone pieces. Choose your desired seating shapes & then select from our wide variety of fabrics to create the ideal look for your space.

COLOR & FINISH OPTIONS

STEP 1 PATTERN SERIES TOP COLOR

Use the name of the textile color as the key code for **STEP 1**

[FAMILY PART] - [PATTERN SERIES] - [TOP COLOR]

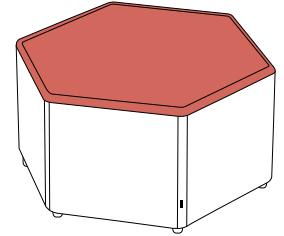

(All blenders come standard with Red double stitching)

STEP 2 PATTERN SERIES SIDES COLOR

Use the name of the textile color as the key code for **STEP 2**

[FAMILY PART] - [PATTERN SERIES] - [TOP COLOR] - [PATTERN SERIES] - [SIDES COLOR]

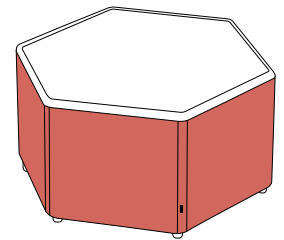

○ MAYER QUATTRO PATTERN SERIES

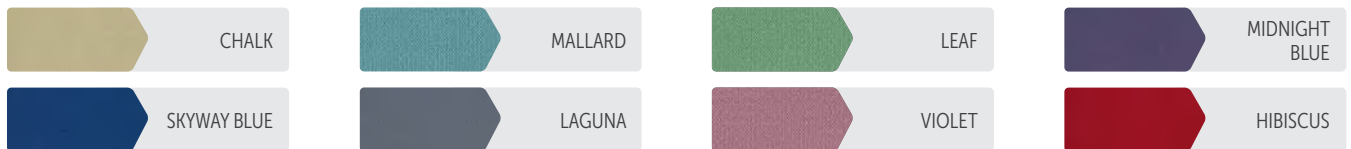

○ CF STINSON LARA PATTERN SERIES

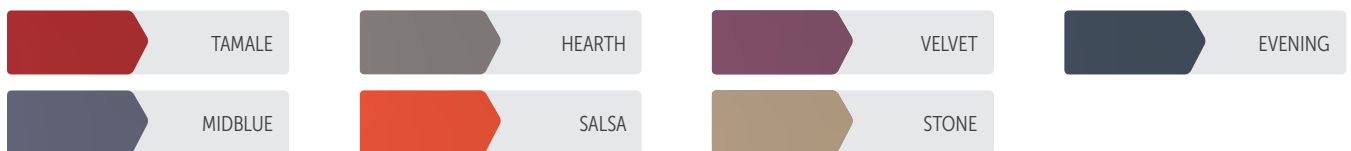

○ MOMENTUM EVO CV PATTERN SERIES



MOMENTUM TRIBECA CV PATTERN SERIES

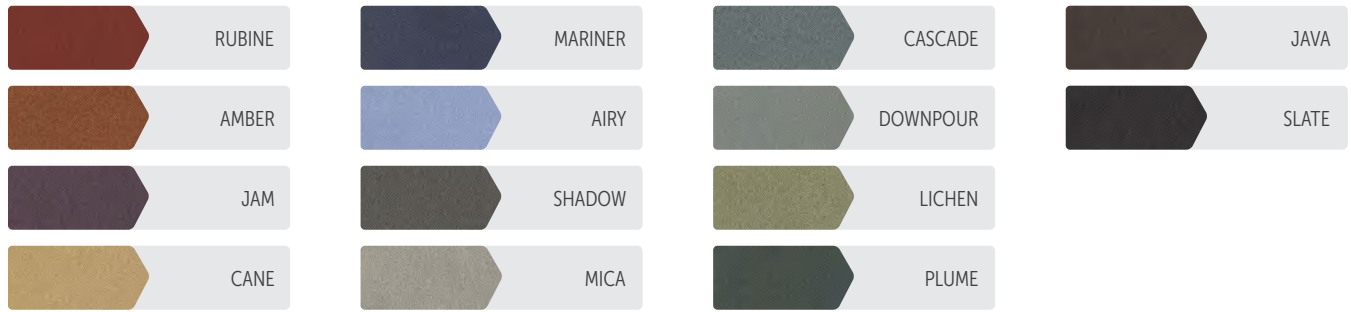

MOMENTUM VANGUARD CV PATTERN SERIES

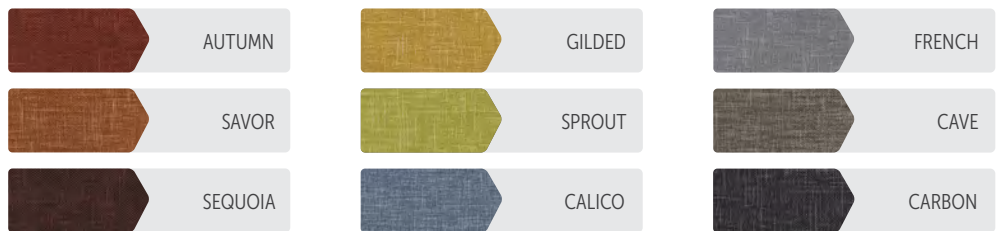

SPRADLING EDGELINE PATTERN SERIES

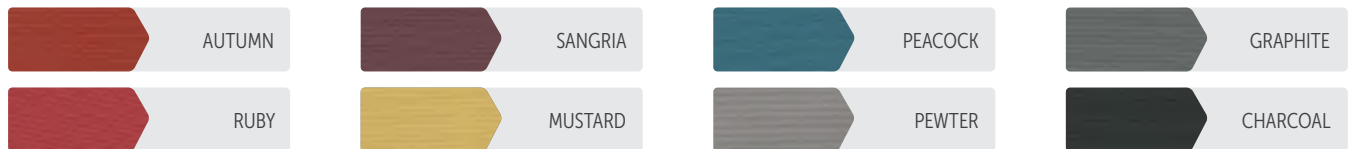

SPRADLING SILVERTEX PATTERN SERIES



GRADED-IN PROGRAM

Soft seating is also available in hundreds of additional textiles through our graded-in program.

Scan the QR code or visit paragoninc.com/textiles for details.

If you have a custom fabric you'd like to use, we also offer a COM option. Contact us for additional information.



MODEL NUMBERS & PRODUCT SPECS

BLENDER® HEXAGON

Model #	Width (in)	Depth (in)	Height (in)	Weight (lbs)	Freight Class (Qty 1)
BLENDHEX1912F	19	16.5	12	15	300
BLENDHEX1915F	19	16.5	15	15	300
BLENDHEX1918F	19	16.5	18	15	300
BLENDHEX2712F	27	23.5	12	25	250
BLENDHEX2715F	27	23.5	15	25	250
BLENDHEX2718F	27	23.5	18	25	250
BLENDHEX3612F	36	32	12	35	250
BLENDHEX3615F	36	32	15	35	250
BLENDHEX3618F	36	32	18	35	250

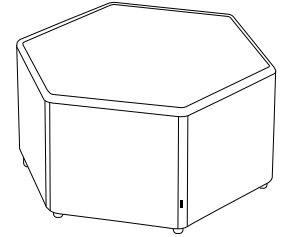

BLENDER® PENTAGON

Model #	Width (in)	Depth (in)	Height (in)	Weight (lbs)	Freight Class (Qty 1)
BLENDPENT2412F	24	16	12	15	250
BLENDPENT2415F	24	16	15	15	250
BLENDPENT2418F	24	16	18	15	250

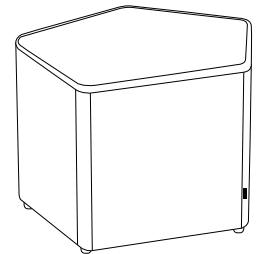

BLENDER® TRAPEZOID

Model #	Width (in)	Depth (in)	Height (in)	Weight (lbs)	Freight Class (Qty 1)
BLENDTRAP3612F	36	16	12	35	250
BLENDTRAP3615F	36	16	15	35	250
BLENDTRAP3618F	36	16	18	35	250

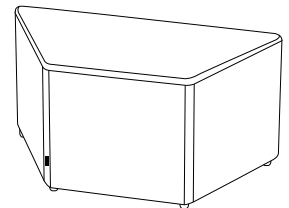

BLENDER® KOI

Model #	Width (in)	Depth (in)	Height (in)	Weight (lbs)	Freight Class (Qty 1)
BLENDKOI3012F	30	20	12	35	250
BLENDKOI3015F	30	20	15	35	250
BLENDKOI3018F	30	20	18	35	250

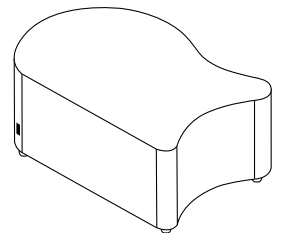





MOTIV®
SEATING &
TABLES



MOTIV® SOFT SEATING

Motiv is an awesome line of soft seating designed & manufactured specifically for schools. Built on solid wood frames with dense foam cushioning & durable textiles, this soft seating can survive the rigors of everyday school use while still looking great. With a multitude of sizes, styles, & colors to choose from, Motiv is the perfect solution for flexible & comfortable learning spaces.



COLOR & FINISH OPTIONS

STEP 1 PATTERN SERIES TOP COLOR

Use the name of the textile color as the key code for **STEP 1**

Color placement varies depending on the model. Go to paragoninc.com/motiv-school-soft-seating for fabric placement charts.

All 18" models are available with Titanium color legs only.

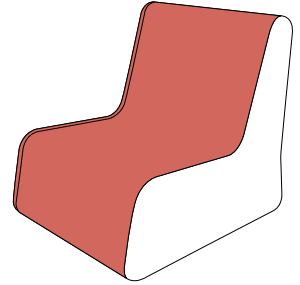

[FAMILY PART] - [PATTERN SERIES] - [TOP COLOR]

STEP 2 PATTERN SERIES SIDES COLOR

Use the name of the textile color as the key code for **STEP 2**

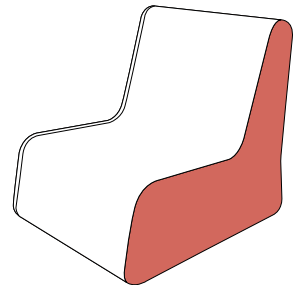

[FAMILY PART] - [PATTERN SERIES] - [TOP COLOR] - [PATTERN SERIES] - [SIDES COLOR]

○ MAYER QUATTRO PATTERN SERIES

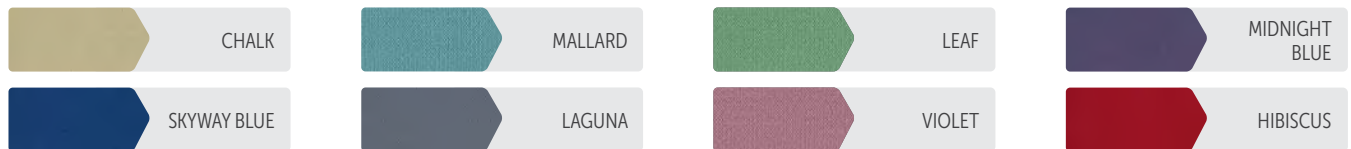

○ CF STINSON LARA PATTERN SERIES

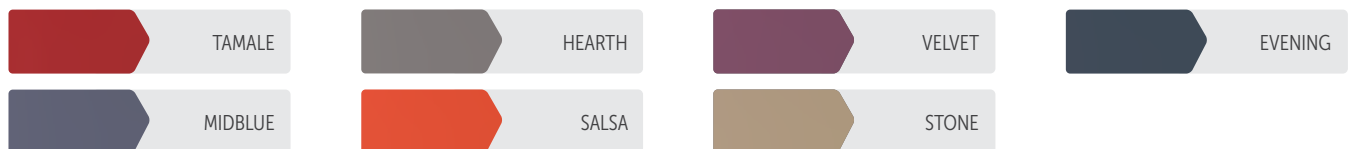

MOMENTUM EVO CV PATTERN SERIES



MOMENTUM TRIBECA CV PATTERN SERIES



MOMENTUM VANGUARD CV PATTERN SERIES



SPRADLING EDGELINE PATTERN SERIES

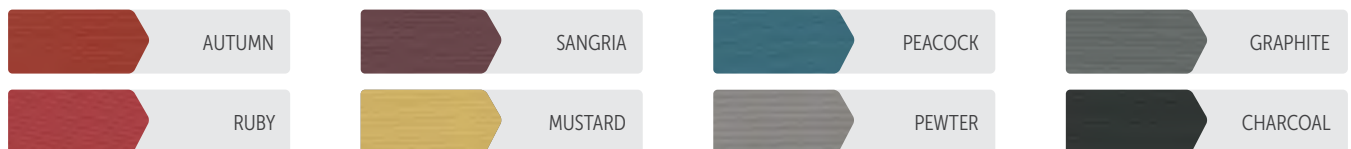

SPRADLING SILVERTEX PATTERN SERIES

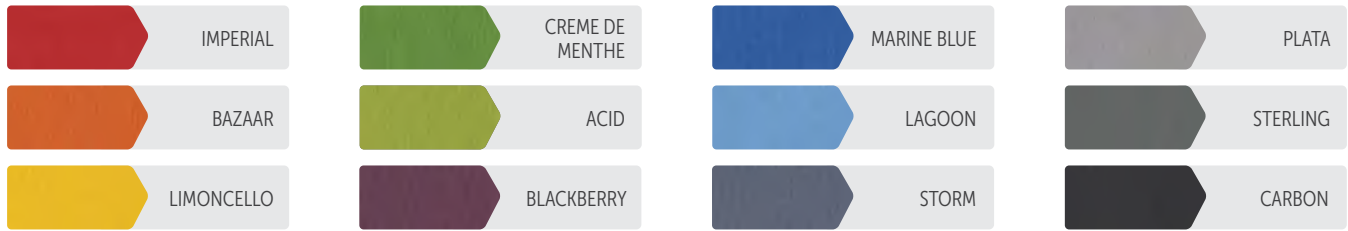

GRADED-IN PROGRAM

Soft seating is also available in hundreds of additional textiles through our graded-in program.

Scan the QR code or visit paragoninc.com/textiles for details.

If you have a custom fabric you'd like to use, we also offer a COM option. Contact us for additional information.



LAMINATE WOOD SURFACES

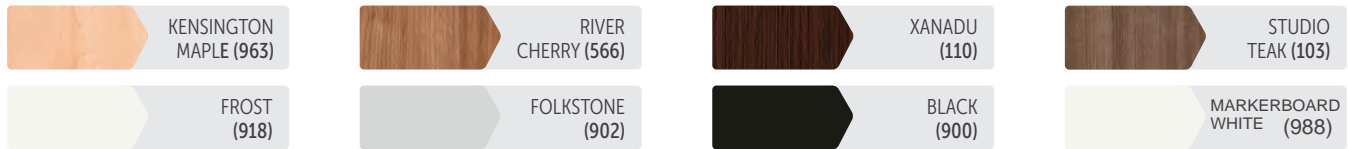

EDGE COLORS FOR LAMINATE SURFACES

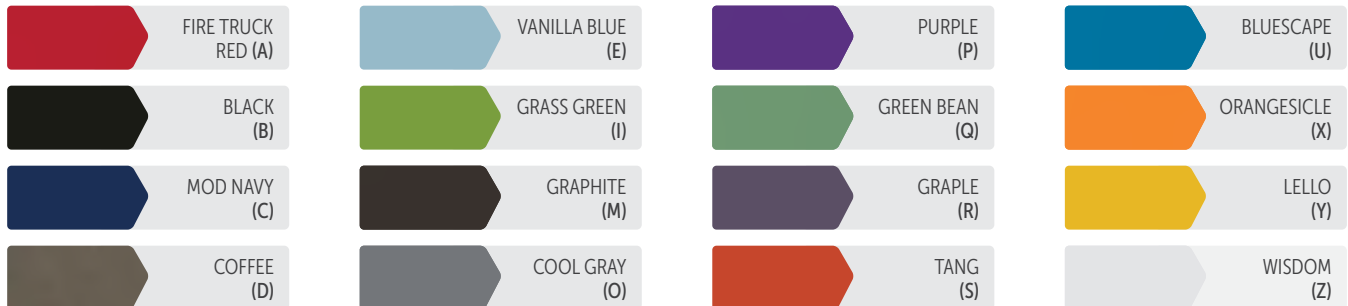

Motiv Bench
with Laminate
Surface

MOTIV 1.0

MOTIV® SEATING FABRIC LOCATION

Please see the diagram below and list fabric choice in accordance to desired location.

ARMED CHAIR A Arms B Back

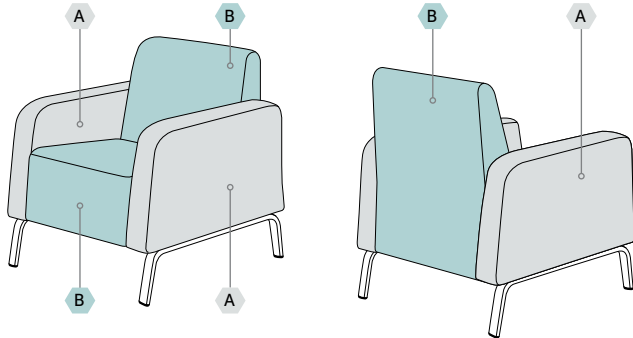

ARMLESS CHAIR A Sides B Seat, Back

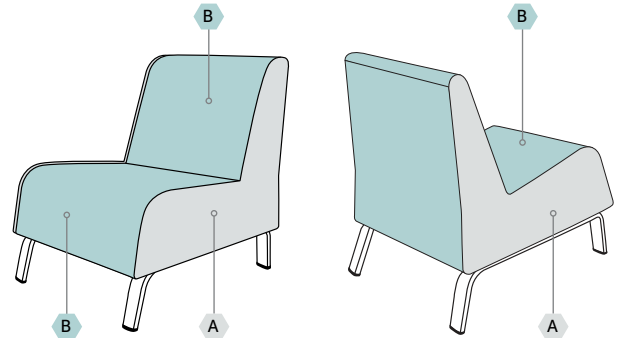

ARMLESS SOFA A Sides B Seat, Back

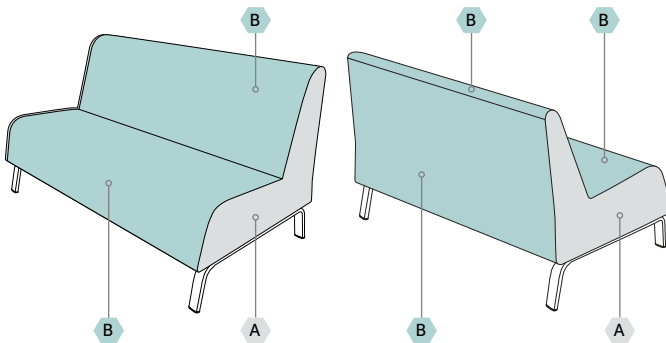

18" BENCH A Sides B Top, Front, Back

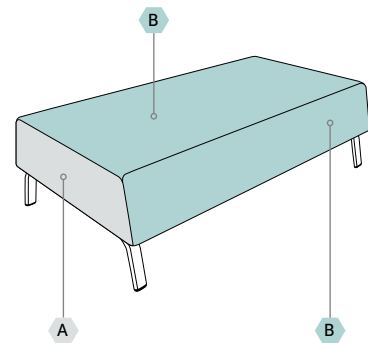

60° & 90° BENCHES

A Sides B Fabric or Laminate Top, Front, Back

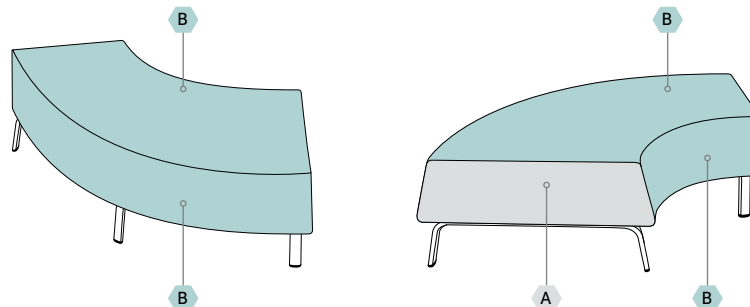

MOTIV 2.0

12" & 15" ARMLESS CHAIR

A Arms B Back

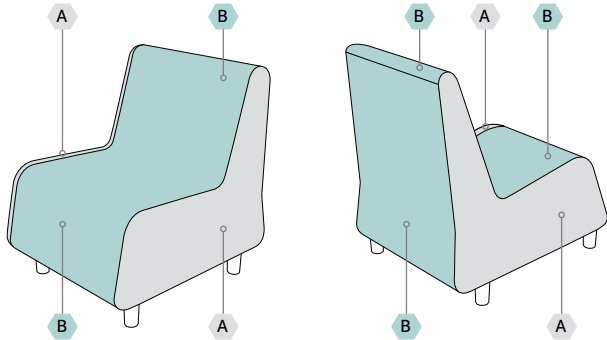

18" ARMLESS CHAIR

A Back, Base
B Seat and Back Cushion

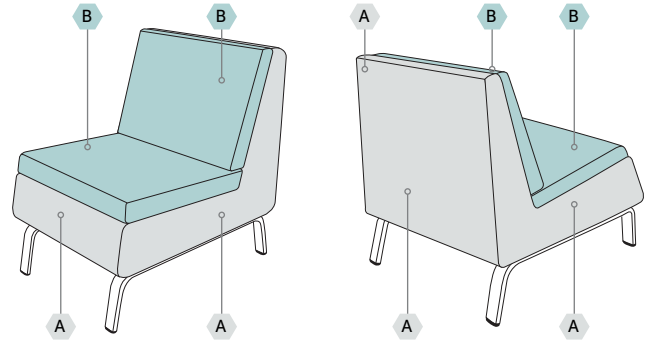

HIGH-BACK SOFA

A Arms, Back, Base
B Seat, Lower back, Upper back cushions

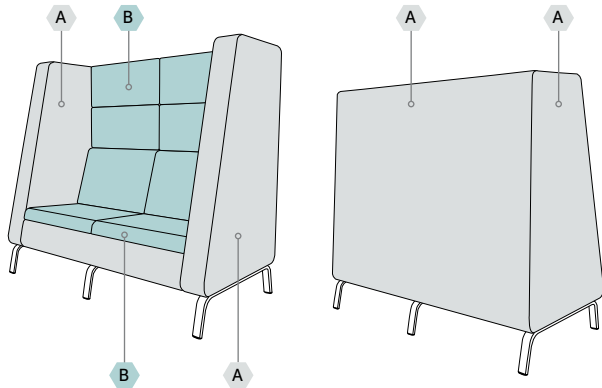

12" & 15" STRAIGHT 60° & 90° BENCHES

A Sides
B Top, Front, Back

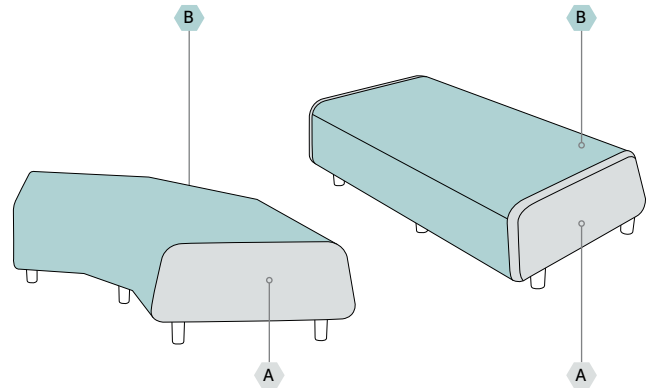

18" STRAIGHT, 60° & 90° BENCHES

A Sides B Top, Front & Back

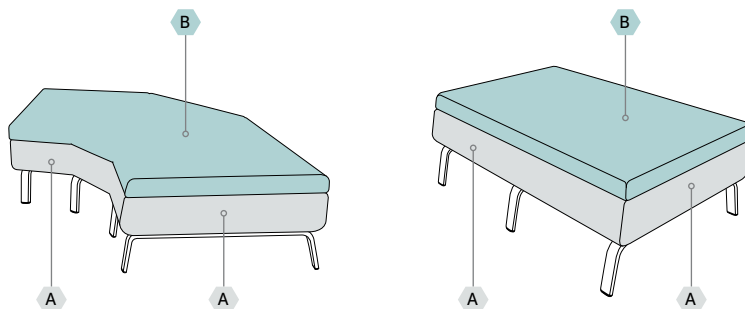

MODEL NUMBERS & PRODUCT SPECS

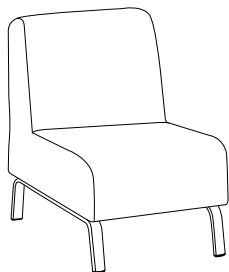

MOTIV 1.0 - 18" H ARMLESS CHAIR

Model #	Width (in)	Depth (in)	Overall Height (in)	Weight (lbs)	Freight Class (Qty 1)
EDUMS300	23	32	34	65	250
EDUMS300PR (Power Right)	23	32	34	65	250
EDUMS300PL (Power Left)	23	32	34	65	250
EDUMB600 (Casters on Front 2 Legs)	23	32	34	65	250

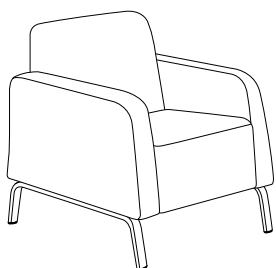

MOTIV 1.0 - 18" H ARM CHAIR

Model #	Width (in)	Depth (in)	Overall Height (in)	Weight (lbs)	Freight Class (Qty 1)
EDUMS350	32	32	34	100	250
EDUMS350PR (Power Right)	32	32	34	105	250
EDUMS350PL (Power Left)	32	32	34	105	250

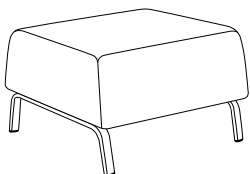

MOTIV 1.0 - 18" H SINGLE BENCH

Model #	Width (in)	Depth (in)	Overall Height (in)	Weight (lbs)	Freight Class (Qty 1)
EDUMDB400	23	32	18	50	150

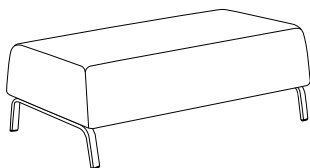

MOTIV 1.0 - 18" H DOUBLE BENCH

Model #	Width (in)	Depth (in)	Overall Height (in)	Weight (lbs)	Freight Class (Qty 1)
EDUMDB600	58	32	18	85	150

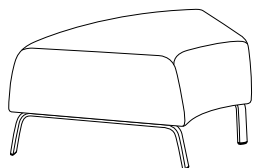

MOTIV 1.0 - 18" H 60° BENCH

Model #	Width (in)	Depth (in)	Overall Height (in)	Weight (lbs)	Freight Class (Qty 1)
EDUMDB660	48	32	18	95	150

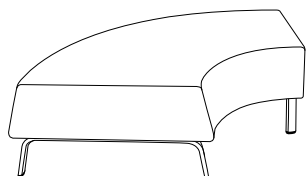

MOTIV 1.0 - 18" H 90° BENCH

Model #	Width (in)	Depth (in)	Overall Height (in)	Weight (lbs)	Freight Class (Qty 1)
EDUMDB690	71	32	18	110	150

MOTIV 1.0 - 18"H 2 SEAT ARMLESS SOFA

Model #	Width (in)	Depth (in)	Overall Height (in)	Weight (lbs)	Freight Class (Qty 1)
EDUML400	58	32	34	145	250
EDUML400P (Power)	58	32	34	155	250

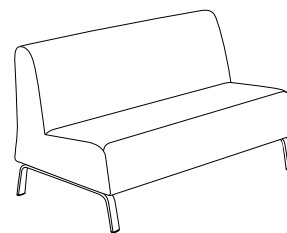

MOTIV 2.0 - 12"H SINGLE CHAIR

Model #	Width (in)	Depth (in)	Overall Height (in)	Weight (lbs)	Freight Class (Qty 1)
MTV10LB12	24	28	27	50	250

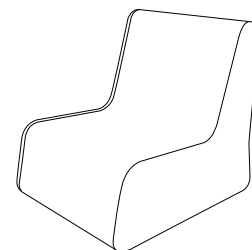

MOTIV 2.0 - 12"H SINGLE STRAIGHT BENCH

Model #	Width (in)	Depth (in)	Overall Height (in)	Weight (lbs)	Freight Class (Qty 1)
MTV10BH12	24	29	12	40	150
MTV10BW12 (W/Top)	24	29	13	40	150

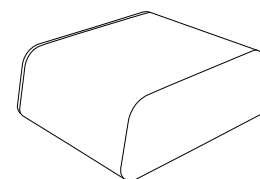

MOTIV 2.0 - 12"H DOUBLE STRAIGHT BENCH

Model #	Width (in)	Depth (in)	Overall Height (in)	Weight (lbs)	Freight Class (Qty 1)
MTV20BH12	48	29	12	60	150

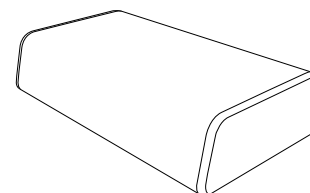

MOTIV 2.0 - 12"H 30° SINGLE BENCH

Model #	Width (in)	Depth (in)	Overall Height (in)	Weight (lbs)	Freight Class (Qty 1)
MTV13BH12	26	28	12	40	150
MTV13BW12 (W/Top)	26	28	13	50	150

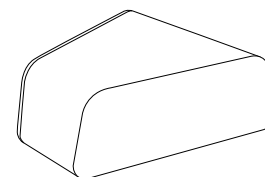

MOTIV 2.0 - 12"H 90° DOUBLE BENCH

Model #	Width (in)	Depth (in)	Overall Height (in)	Weight (lbs)	Freight Class (Qty 1)
MTV29BH12	70	33	12	120	150

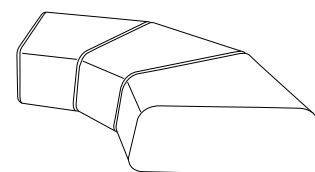

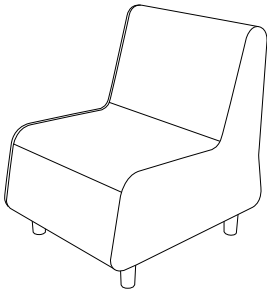

MOTIV 2.0 - 15"H SINGLE CHAIR

Model #	Width (in)	Depth (in)	Overall Height (in)	Weight (lbs)	Freight Class (Qty 1)
MTV10LB15	24	28	30	50	250
MTV10LB15-PF (Power Front)	24	28	30	50	250
MTV10LB15C (Casters)	24	28	30	50	250
MTV10LB15C-PF (Casters +Power Front)	24	28	30	50	250

(Models with casters come with casters on 2 legs only)

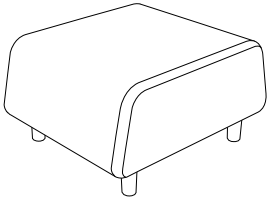

MOTIV 2.0 - 15"H SINGLE BENCH

Model #	Width (in)	Depth (in)	Overall Height (in)	Weight (lbs)	Freight Class (Qty 1)
MTV10BH15	24	29	15	40	150
MTV10BH15C (Casters)	24	29	15	40	150
MTV10BW15 (W/Top)	24	29	16	50	150
MTV10BW15C (Casters + Top)	24	29	16	50	150

(Models with casters come with casters on 2 legs only)

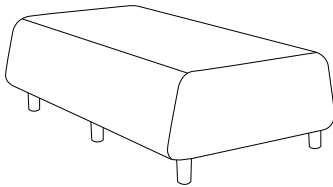

MOTIV 2.0 - 15"H DOUBLE BENCH

Model #	Width (in)	Depth (in)	Overall Height (in)	Weight (lbs)	Freight Class (Qty 1)
MTV20BH15	48	29	15	60	150
MTV20BH15C (Casters)	48	29	15	60	150

(Models with casters come with casters on 2 legs only)

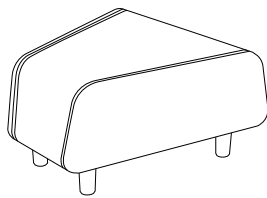

MOTIV 2.0 - 15"H 30° SINGLE BENCH

Model #	Width (in)	Depth (in)	Overall Height (in)	Weight (lbs)	Freight Class (Qty 1)
MTV13BH15	26	28	15	40	150
MTV13BW15 (W/Top)	26	28	16	50	150
MTV13BH15C (Casters)	26	28	15	40	150
MTV13BW15C (Casters + Top)	26	28	16	50	150

(Models with casters come with casters on 2 legs only)

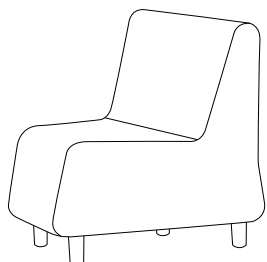

MOTIV 2.0 - 15"H 30° SINGLE BENCH W/BACK

Model #	Width (in)	Depth (in)	Overall Height (in)	Weight (lbs)	Freight Class (Qty 1)
MTV13LB15	26	28	30	50	250
MTV13LB15C (W/ Casters)	26	28	30	50	250

(Models with casters come with casters on 2 legs only)

MOTIV 2.0 - 15"H 90° DOUBLE BENCH

Model #	Width (in)	Depth (in)	Overall Height (in)	Weight (lbs)	Freight Class (Qty 1)
MTV29BH15	70	33	15	120	150
MTV29BH15C (Casters)	70	33	15	120	150

(Models with casters come with casters on 2 legs only)

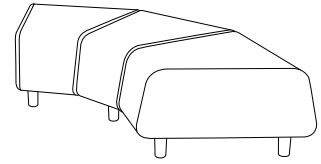

MOTIV 2.0 - 18"H SINGLE CHAIR

Model #	Width (in)	Depth (in)	Overall Height (in)	Weight (lbs)	Freight Class (Qty 1)
MTV10LB18	24	32	33	80	250
MTV10LB18C (Casters)	24	32	33	80	250
MTV10LB18-PF (W/Power Front)	24	32	33	80	250
MTV10LB18C-PF (W/Casters & Power Front)	24	32	33	80	250

(Models with casters come with casters on 2 legs only)

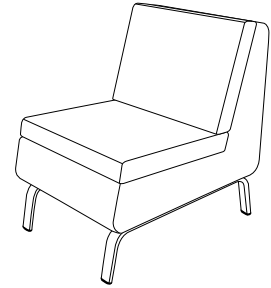

MOTIV 2.0 - 18"H SINGLE BENCH

Model #	Width (in)	Depth (in)	Overall Height (in)	Weight (lbs)	Freight Class (Qty 1)
MTV10BH18	22	31	18	60	150
MTV10BW18 (W/Top)	22	31	19	70	150

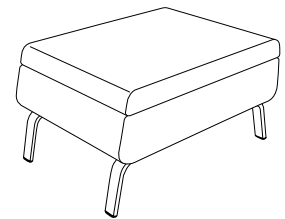

MOTIV 2.0 - 18"H DOUBLE BENCH

Model #	Width (in)	Depth (in)	Overall Height (in)	Weight (lbs)	Freight Class (Qty 1)
MTV20BH18	48	31	18	90	150

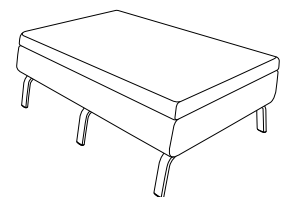

MOTIV 2.0 - 18"H 30° SINGLE BENCH

Model #	Width (in)	Depth (in)	Overall Height (in)	Weight (lbs)	Freight Class (Qty 1)
MTV13BH18	30	30	18	60	150
MTV13BW18 (W/Top)	30	30	19	70	150

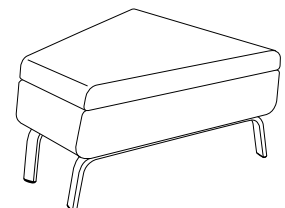

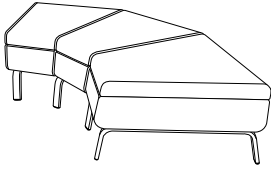

MOTIV 2.0 - 18" H 90° DOUBLE BENCH

Model #	Width (in)	Depth (in)	Overall Height (in)	Weight (lbs)	Freight Class (Qty 1)
MTV29BH18	78	37	18	170	150

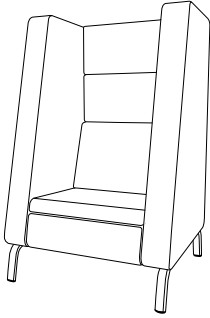

MOTIV 2.0 - 18" H SINGLE HIGH-BACK ARMED CHAIR

Model #	Width (in)	Depth (in)	Overall Height (in)	Weight (lbs)	Freight Class (Qty 1)
MTV10HA18	37	32	57	200	250
MTV10HA18-PF (W/Power Front)	37	32	57	200	250

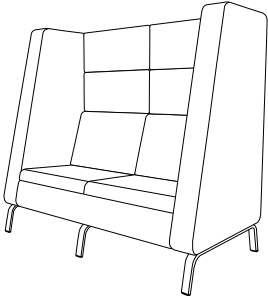

MOTIV 2.0 - 18" H DOUBLE HIGH-BACK ARMED SOFA

Model #	Width (in)	Depth (in)	Overall Height (in)	Weight (lbs)	Freight Class (Qty 1)
MTV20HA18	63	32	57	290	250
MTV20HA18-PF (W/Power Front)	63	32	57	290	250

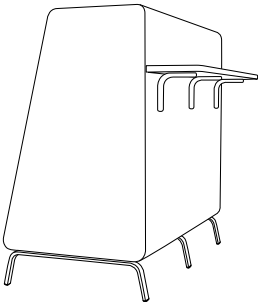

MOTIV 2.0 - 18" H DOUBLE HIGH-BACK ARMED SOFA W/ SHELF

Model #	Width (in)	Depth (in)	Overall Height (in)	Weight (lbs)	Freight Class (Qty 1)
MTV20HA18L (29" Shelf)	63	42	57	300	250
MTV20HA18L-PF (29" Shelf W/Power Front)	63	42	57	300	250
MTV20HA18L-PA (29" Shelf W/Power Front & Rear)	63	42	57	300	250
MTV20HA18H (45" Shelf)	63	42	57	300	250
MTV20HA18H-PF (45" Shelf W/Power Front)	63	42	57	300	250
MTV20HA18H-PA (45" Shelf W/Power Front & Rear)	63	42	57	300	250

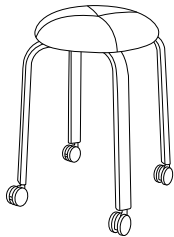

MOTIV STOOL

Model #	Width (in)	Depth (in)	Overall Height (in)	Weight (lbs)	Freight Class (Qty 1)
EDUMSKL (Glides)	22	22	15	30	250
EDUMSKH (Glides)	22	22	20	30	250
EDUMSKLC (Casters)	22	22	15	30	250
EDUMSKHC (Casters)	22	22	20	30	250



MOTIV™ OCCASIONAL TABLES

MOTIV® Occasional Tables are complementary to MOTIV® Soft Seating. Tables come in a laminate top & are offered in round, rectangle, or square shapes.

FEATURES

- Quality construction in a classic design that complements any Motiv[™] Freestanding or Modular soft seating environment.
- Available with circular, square or rectangular work surfaces.
- All tables have a height of 16" & feature four (4) leg construction using the same flat oval steel tubing used on Motiv[™] soft seating pieces.
- Tables meet or exceed ANSI BIFMA X5.5-2008 standards.



CONFIGURING A MODEL NUMBER

Refer to the Model Numbers & Product Specs section for a list of all family part model numbers in this product line. Use the chart below as a reference for how to properly specify this product.

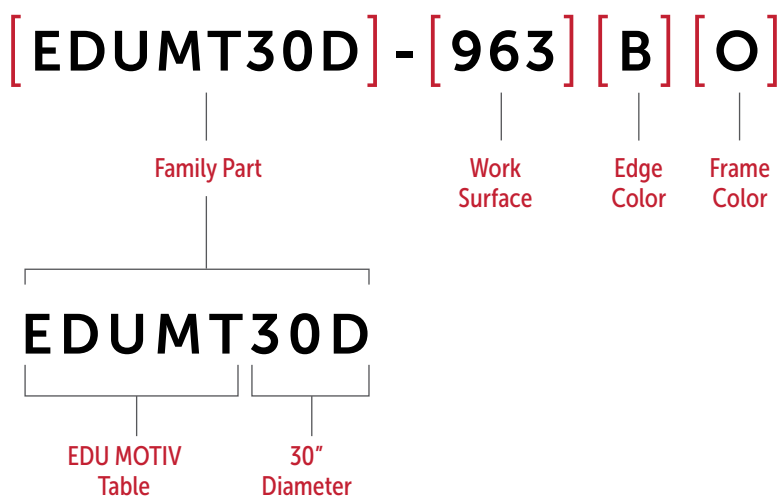

COLOR & FINISH OPTIONS

STEP 1 WORK SURFACE

Use the number next to the laminate name as the key code for **STEP 1**

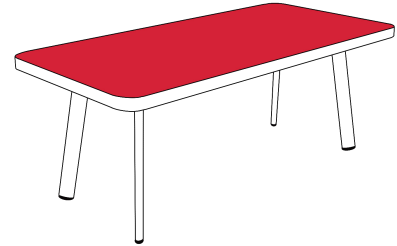

[FAMILY PART] - [WORK SURFACE]

SOLID LAMINATE

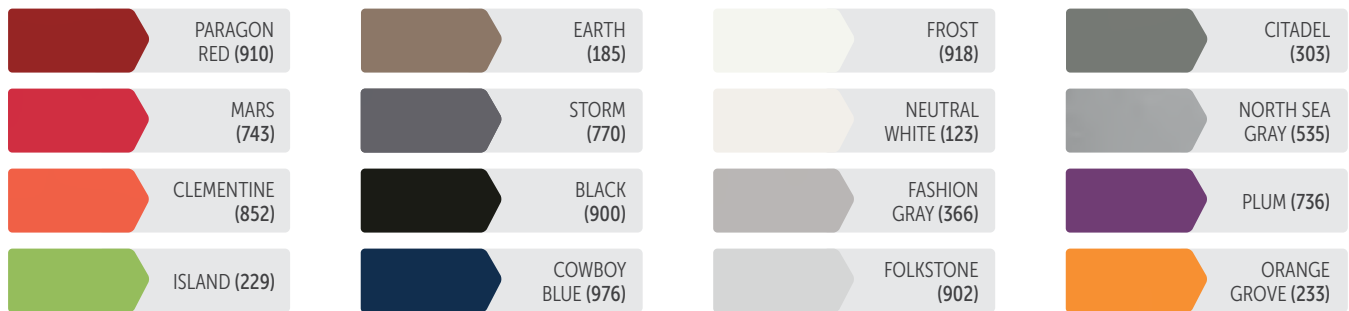

WHITEBOARD LAMINATE



WOOD GRAIN LAMINATE

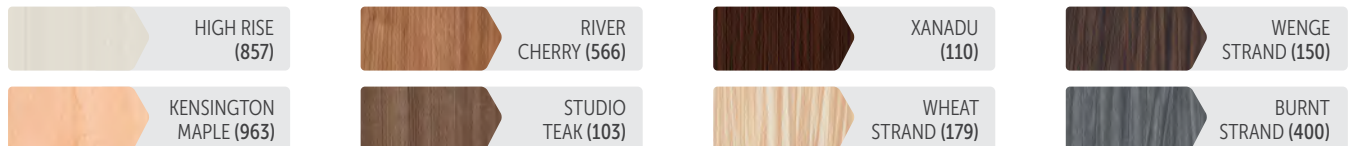

PATTERN LAMINATE



NEW COLORS

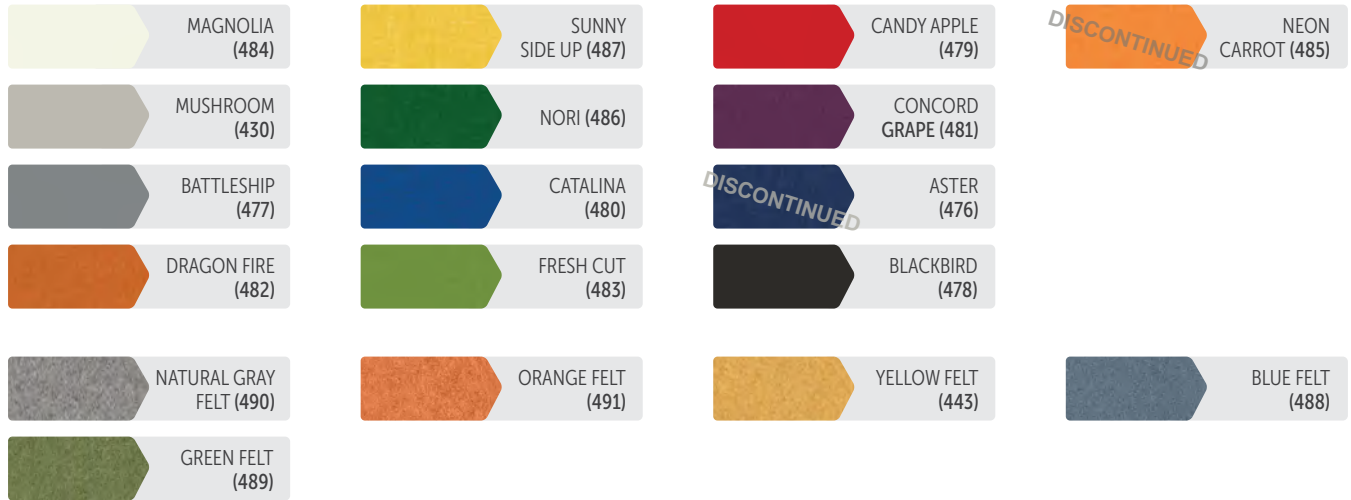

**STEP 2
EDGE**

Use the letter next to the color name as the key code for **STEP 2**. For tables specified with a knife edge, do not specify an edge color

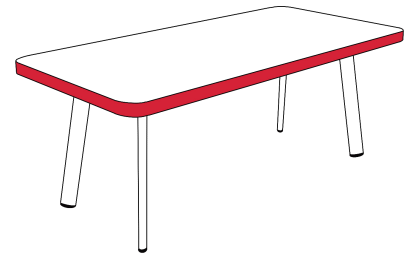

[FAMILY] - [WORK] [EDGE]
[PART] - [SURFACE] [COLOR]

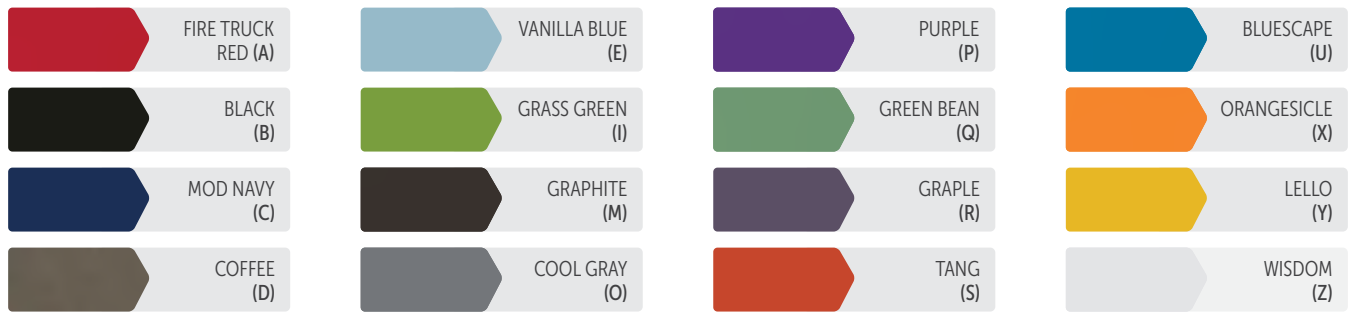

**STEP 3
FRAME**

Use the letter next to the color name as the key code for **STEP 3**

[FAMILY] - [WORK] [EDGE] [FRAME]
[PART] - [SURFACE] [COLOR] [COLOR]



MODEL NUMBERS & PRODUCT SPECS

MOTIV™ OCCASIONAL TABLE - RECTANGLE SURFACE

Model #	Width (in)	Depth (in)	Height (in)	Weight (lbs)	Freight Class (Qty 1)
EDUMT4220	42	20	16	80	85
EDUMT4220-K	42	20	16	80	85

-K indicates a knife edge

KNIFE EDGE DISCONTINUED

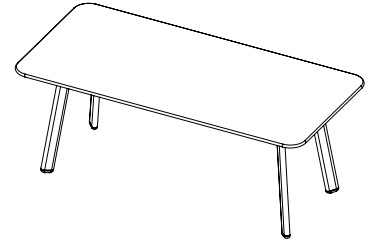

MOTIV™ OCCASIONAL TABLE - ROUND SURFACE

Model #	Width (in)	Depth (in)	Height (in)	Weight (lbs)	Freight Class (Qty 1)
EDUMT24D	24	24	16	55	85
EDUMT24D-K	24	24	16	55	85
EDUMT30D	30	30	16	60	85
EDUMT30D-K	30	30	16	60	85
EDUMT36D	36	36	16	65	85
EDUMT36D-K	36	36	16	65	85

-K indicates a knife edge

KNIFE EDGE DISCONTINUED

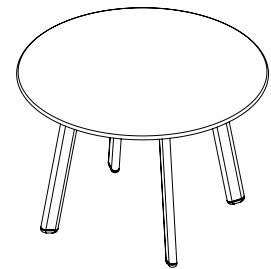

MOTIV™ OCCASIONAL TABLE - SQUARE SURFACE

Model #	Width (in)	Depth (in)	Height (in)	Weight (lbs)	Freight Class (Qty 1)
EDUMT2020	20	20	16	50	85
EDUMT2020-K	20	20	16	50	85
EDUMT2424	24	24	16	55	85
EDUMT2424-K	24	24	16	55	85
EDUMT3030	30	30	16	60	85
EDUMT3030-K	30	30	16	60	85

-K indicates a knife edge

KNIFE EDGE DISCONTINUED

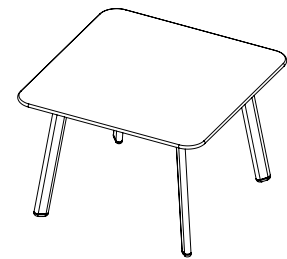



HIGH SCHOOL
RIVER HAWKS





STORAGE
&
SHELVING



A&D[®] CROSSFIT MOBILE STORAGE

Enhance any learning environment with A&D[®] Crossfit Storage solutions. Choose units with open fronts or with doors. Then choose the interior cabinet configuration; all totes, all shelves or a standard combination of totes & shelves. All units come standard with 3" heavy duty locking casters.

FEATURES

○ SURFACE/EDGE

The top surface & optional shelving consist of ¾" thermally fused melamine with 3mm PVC edgeband.

○ FRAME

This product is uniquely designed with a combination of our flattened oval tubing & ¾" thermally fused melamine. The 16-gauge perforated sides have welded supports for "Paragon durability" & provide a cohesive design with the A&D® line.

○ HEAVY DUTY CASTERS

Crossfit Storage is designed for easy mobility with 3" heavy duty locking casters.

○ SHELVES & TOTES

All Crossfit Storage can be outfitted with shelves or totes or a combination of both. Totes are 3" deep.

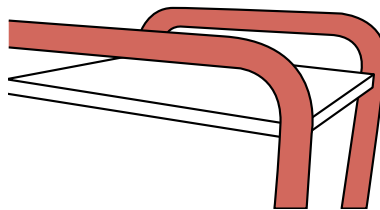

RADIUS HANDLES

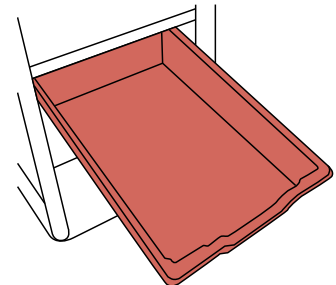

REMOVABLE TOTES

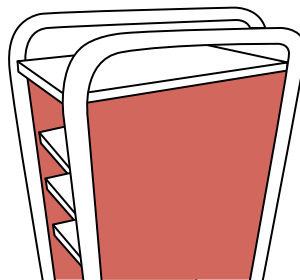

PERFORATED ACCENT SIDE
PANELS & DOORS

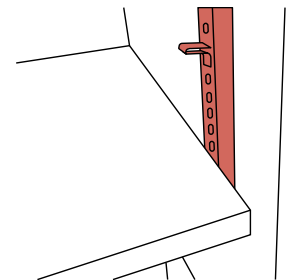

FLOATING ADJUSTABLE
SHELVES



CONFIGURING A MODEL NUMBER

Refer to the Model Numbers & Product Specs section for a list of all family part model numbers in this product line. Use the chart below as a reference for how to properly specify this product.

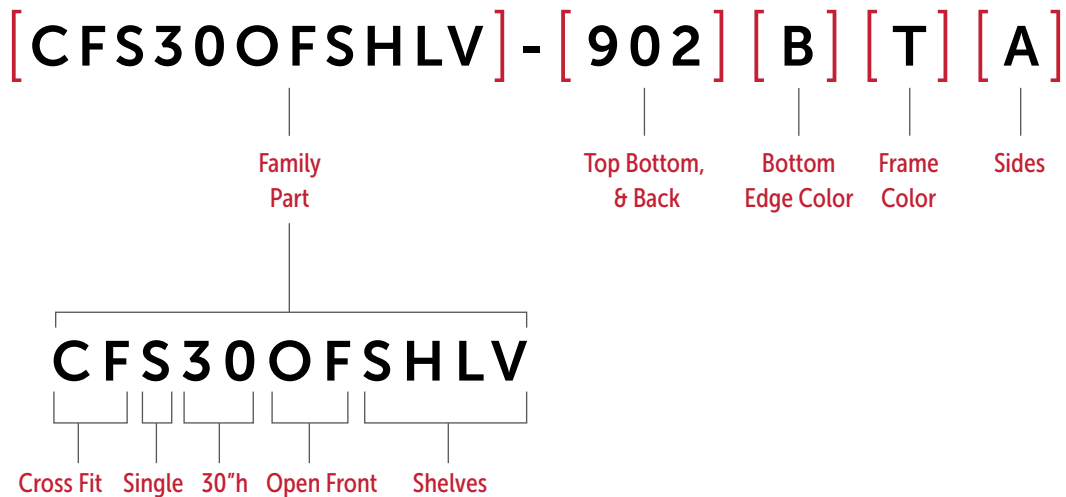

COLOR & FINISH OPTIONS

STEP 1 TOP, BOTTOM, & BACK

Use the number next to the Melamine name as the key code for **STEP 1**
Top, Bottom, Shelves & Back are finished in the same color. Select one color from the pallet below to represent all areas.

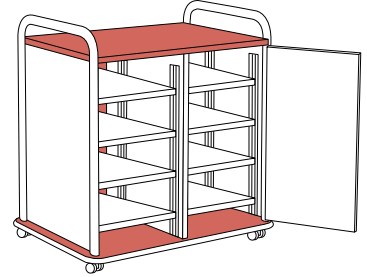

[FAMILY] - [TOP, BOTTOM, & BACK]
[PART]

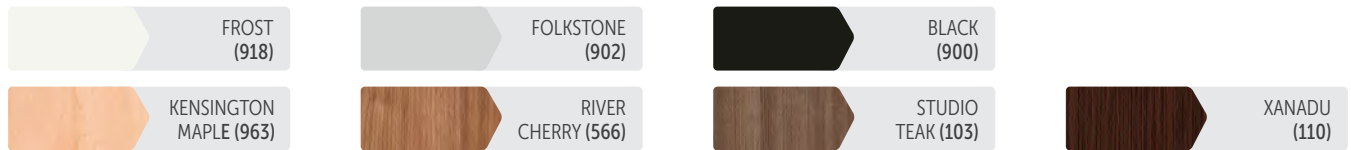

STEP 2 BOTTOM EDGE

Use the letter next to the edge color as the key code for **STEP 2**

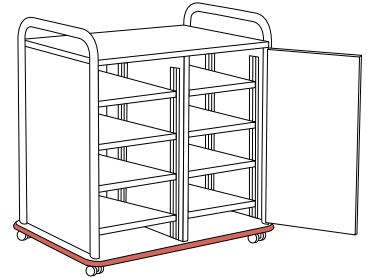

[FAMILY] - [TOP, BOTTOM, & BACK] [BOTTOM]
[PART] [EDGE]

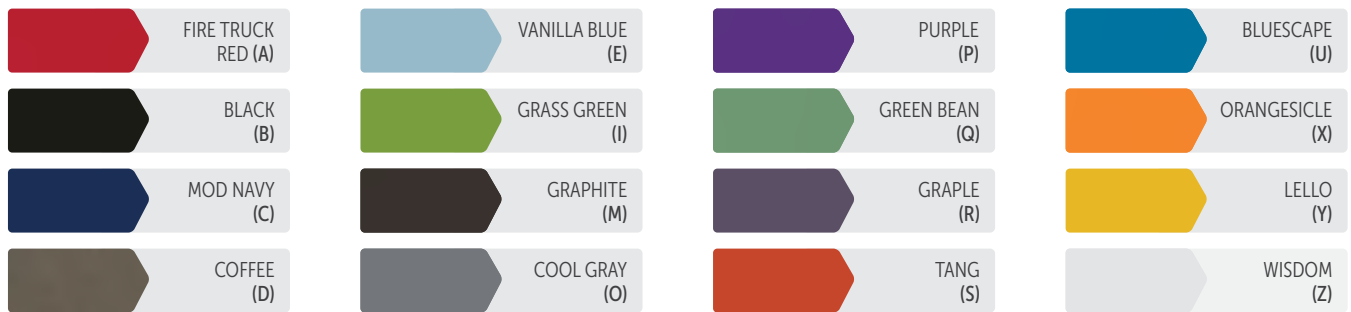

STEP 3 FRAME

Choose your frame color. Refer to the Frame Color Key to locate the key code for **STEP 3**

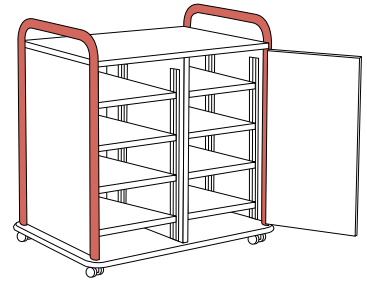

[FAMILY PART] - [TOP, BOTTOM, & BACK] [BOTTOM EDGE] [FRAME COLOR]



STEP 4 SIDES & DOORS

Use the letter next to the color name as the key code for **STEP 4**.

Sides & Doors are finished in the same color. Select one color from the palette below to represent all areas.

*Black & Graphite paints are a textured paint.

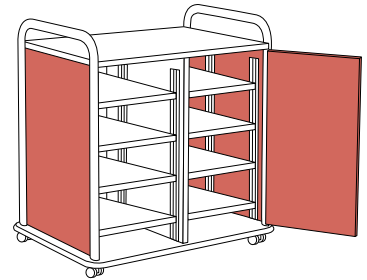

[FAMILY PART] - [TOP, BOTTOM, & BACK] [BOTTOM EDGE] [FRAME COLOR] [SIDES & DOORS]

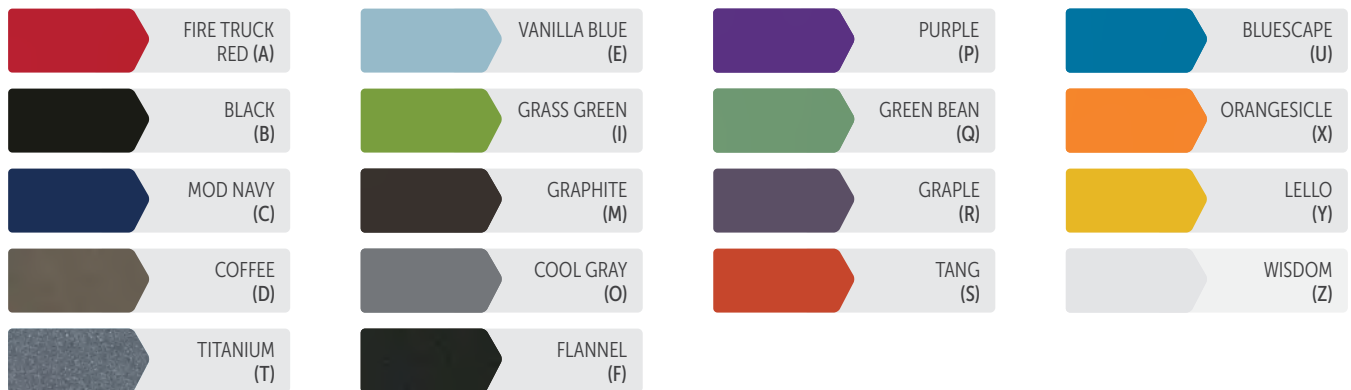

MODEL NUMBERS & PRODUCT SPECS

A&D® SINGLE CROSSFIT STORAGE 30"

Model #		Width (in)	Depth (in)	Height (in)	Weight (lbs)	Freight Class (Qty 1)
CFS30OFSHLV	(4 Shelves)	17	22	34	80	125
CFS30WDSHLV	(4 Shelves)	17	22	34	80	125
CFS30OFTOTES14	(7 Totes)	17	22	34	70	125
CFS30WDTOTES14	(7 Totes)	17	22	34	70	125
CFS30OFTOTES17	(7 Totes)	17	22	34	70	125
CFS30WDTOTES17	(7 Totes)	17	22	34	70	125
CFS30OF14CO	(2 Shelves, 3 Totes)	17	22	34	75	125
CFS30WD14CO	(2 Shelves, 3 Totes)	17	22	34	75	125
CFS30OF17CO	(2 Shelves, 3 Totes)	17	22	34	75	125
CFS30WD17CO	(2 Shelves, 3 Totes)	17	22	34	75	125

OF = Open Front WD = With Doors SHLV = Shelves Only TOTES = Totes Only CO = Combination Shelves & Totes
14 = 14" Deep Totes 17 = 17" Deep Totes

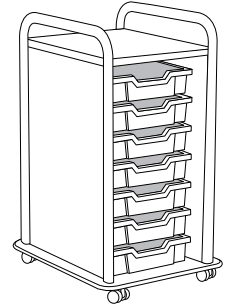

A&D® SINGLE CROSSFIT STORAGE 42"

Model #		Width (in)	Depth (in)	Height (in)	Weight (lbs)	Freight Class (Qty 1)
CFS42OFSHLV	(6 Shelves)	17	22	46	110	125
CFS42WDSHLV	(6 Shelves)	17	22	46	110	125
CFS42OFTOTES14	(11 Totes)	17	22	46	105	125
CFS42WDTOTES14	(11 Totes)	17	22	46	105	125
CFS42OFTOTES17	(11 Totes)	17	22	46	105	125
CFS42WDTOTES17	(11 Totes)	17	22	46	105	125
CFS42OF14CO	(2 Shelves, 7 Totes)	17	22	46	105	125
CFS42WD14CO	(2 Shelves, 7 Totes)	17	22	46	105	125
CFS42OF17CO	(2 Shelves, 7 Totes)	17	22	46	105	125
CFS42WD17CO	(2 Shelves, 7 Totes)	17	22	46	105	125

OF = Open Front WD = With Doors SHLV = Shelves Only TOTES = Totes Only CO = Combination Shelves & Totes
14 = 14" Deep Totes 17 = 17" Deep Totes

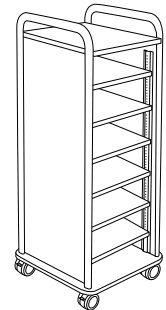

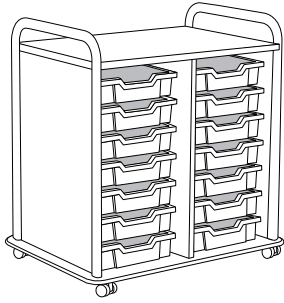

A&D® DOUBLE CROSSFIT STORAGE 30"

Model #		Width (in)	Depth (in)	Height (in)	Weight (lbs)	Freight Class (Qty 1)
CFD30OFSHLV	(8 Shelves)	33	22	34	145	125
CFD30WDSHLV	(8 Shelves)	33	22	34	145	125
CFD30OFTOTES14	(14 Totes)	33	22	34	125	125
CFD30WDTOTES14	(14 Totes)	33	22	34	125	125
CFD30OFTOTES17	(14 Totes)	33	22	34	125	125
CFD30WDTOTES17	(14 Totes)	33	22	34	125	125
CFD30OF14CO	(4 Shelves, 6 Totes)	33	22	34	135	125
CFD30WD14CO	(4 Shelves, 6 Totes)	33	22	34	135	125
CFD30OF17CO	(4 Shelves, 6 Totes)	33	22	34	135	125
CFD30WD17CO	(4 Shelves, 6 Totes)	33	22	34	135	125

OF = Open Front WD = With Doors SHLV = Shelves Only TOTES = Totes Only CO = Combination Shelves & Totes
14 = 14" Deep Totes 17 = 17" Deep Totes



A&D® DOUBLE CROSSFIT STORAGE 42"

Model #		Width (in)	Depth (in)	Height (in)	Weight (lbs)	Freight Class (Qty 1)
CFD42OFSHLV	(12 Shelves)	33	22	46	205	125
CFD42WDSHLV	(12 Shelves)	33	22	46	205	125
CFD42OFTOTES14	(22 Totes)	33	22	46	185	125
CFD42WDTOTES14	(22 Totes)	33	22	46	185	125
CFD42OFTOTES17	(22 Totes)	33	22	46	185	125
CFD42WDTOTES17	(22 Totes)	33	22	46	185	125
CFD42OF14CO	(4 Shelves, 14 Totes)	33	22	46	195	125
CFD42WD14CO	(4 Shelves, 14 Totes)	33	22	46	195	125
CFD42OF17CO	(4 Shelves, 14 Totes)	33	22	46	195	125
CFD42WD17CO	(4 Shelves, 14 Totes)	33	22	46	195	125

OF = Open Front WD = With Doors SHLV = Shelves Only TOTES = Totes Only CO = Combination Shelves & Totes
14 = 14" Deep Totes 17 = 17" Deep Totes

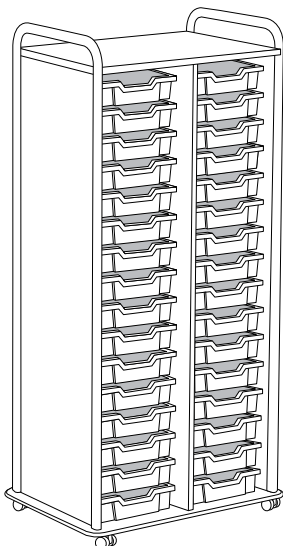

A&D® DOUBLE CROSSFIT STORAGE 60"

Model #		Width (in)	Depth (in)	Height (in)	Weight (lbs)	Freight Class (Qty 1)
CFD60OFSHLV	(18 Shelves)	33	22	64	270	125
CFD60WDSHLV	(18 Shelves)	33	22	64	270	125
CFD60OFTOTES14	(32 Totes)	33	22	64	240	125
CFD60WDTOTES14	(32 Totes)	33	22	64	240	125
CFD60OFTOTES17	(32 Totes)	33	22	64	240	125
CFD60WDTOTES17	(32 Totes)	33	22	64	240	125
CFD60OF14CO	(4 Shelves, 20 Totes)	33	22	64	260	125
CFD60WD14CO	(4 Shelves, 20 Totes)	33	22	64	260	125
CFD60OF17CO	(4 Shelves, 20 Totes)	33	22	64	260	125
CFD60WD17CO	(4 Shelves, 20 Totes)	33	22	64	260	125

OF = Open Front WD = With Doors SHLV = Shelves Only TOTES = Totes Only CO = Combination Shelves & Totes
14 = 14" Deep Totes 17 = 17" Deep Totes



FILE-IT MOBILE FILING CABINET

The file pedestal on casters is ideal for your mobile storage requirements. The box/box/file design is available in cheerful, bold colors to match &/or add a burst of color to any area. Top drawer includes a organizing pencil tray. File drawer includes lateral file divider.

FEATURES

Paragon FILE-IT Mobile Filing Pedestals are designed & manufactured specifically for educational environments. They are flexible, functional, durable, & look great too!

CONSTRUCTION

Made with solid, 18-gauge steel construction for added durability in educational environments.

MOBILITY

All FILE-IT Mobile Filing Cabinet Pedestals come standard with smooth rolling casters for easy mobility.

COLORS

Available in numerous standard & playful colors.



CONFIGURING A MODEL NUMBER

Refer to the Model Numbers & Product Specs section for a list of all family part model numbers in this product line. Use the chart below as a reference for how to properly specify this product.

[FILE-IT] - [A]

Family
Part

Frame
Color

COLOR & FINISH OPTIONS

STEP 1 FRAME

Use the letter next to the frame color name as the key code for **STEP 1**

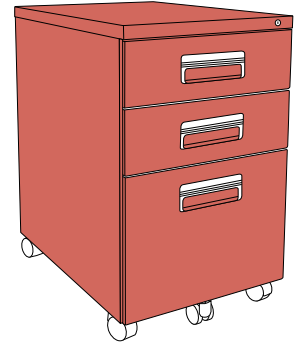

[FAMILY PART] - [FRAME COLOR]



FIRE TRUCK
RED (A)



VANILLA BLUE
(E)



PURPLE
(P)



BLUESCAPE
(U)



BLACK
(B)



GRASS GREEN
(I)



GREEN BEAN
(Q)



ORANGESICLE
(X)



MOD NAVY
(C)



GRAPHITE
(M)



GRAPLE
(R)



LELLO
(Y)



COFFEE
(D)



COOL GRAY
(O)



TANG
(S)



WISDOM
(Z)



FLANNEL
(F)



TITANIUM
(T)

MODEL NUMBERS & PRODUCT SPECS

FILE-IT

Model #	Width (in)	Depth (in)	Height (in)	Weight (lbs)	Freight Class (Qty 1)
FILE-IT	15.5	21.5	25	80	125
FILE-IT-HANG	15.5	21.5	27	80	125

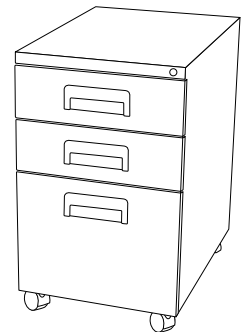



A&D[®] CROSSFIT SWEEP & DASH MOBILE SHELVING

A&D[®] Crossfit Sweep Curved Mobile Shelving is designed and manufactured specifically for education environments. They are flexible, functional, durable, and look great too!

FEATURES

○ SURFACE/EDGE

The unit consists of ¾" thermally fused melamine with 3mm edge band and a perforated metal back panel. The bottom is edged with edge band.

○ FRAME

This product is uniquely designed with a combination of our flattened oval tubing & ¾" thermally fused melamine.

○ SHAPES

The Sweep is curved and the Dash is straight.

○ SIZES

Both Sweep & Dash are available in 38.5" height & 48.5" height.

○ COLORS

Multiple accent colors available to customize the look of the Sweep & Dash.



○ RADIUS HANDLES

Steel rails give the structure additional strength and double as convenient handles for ease of movement.

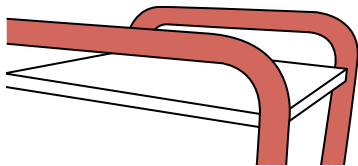

○ EDGE BANDING

Durable edge banding surrounds the base and gives added protection from damage.

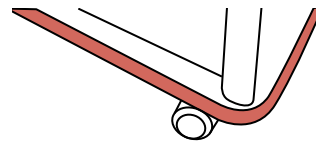

○ FLOATING ADJUSTABLE SHELVES

Adjustable shelves can be moved with ease to accommodate all book and storage needs.

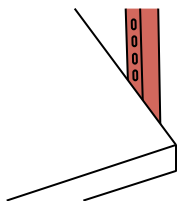

○ LARGE DURABLE CASTERS

All Sweep & Dash units come standard with large, durable locking casters.

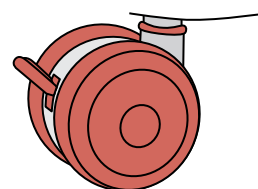

SWEEP MOBILE SHELVING CONFIGURATIONS

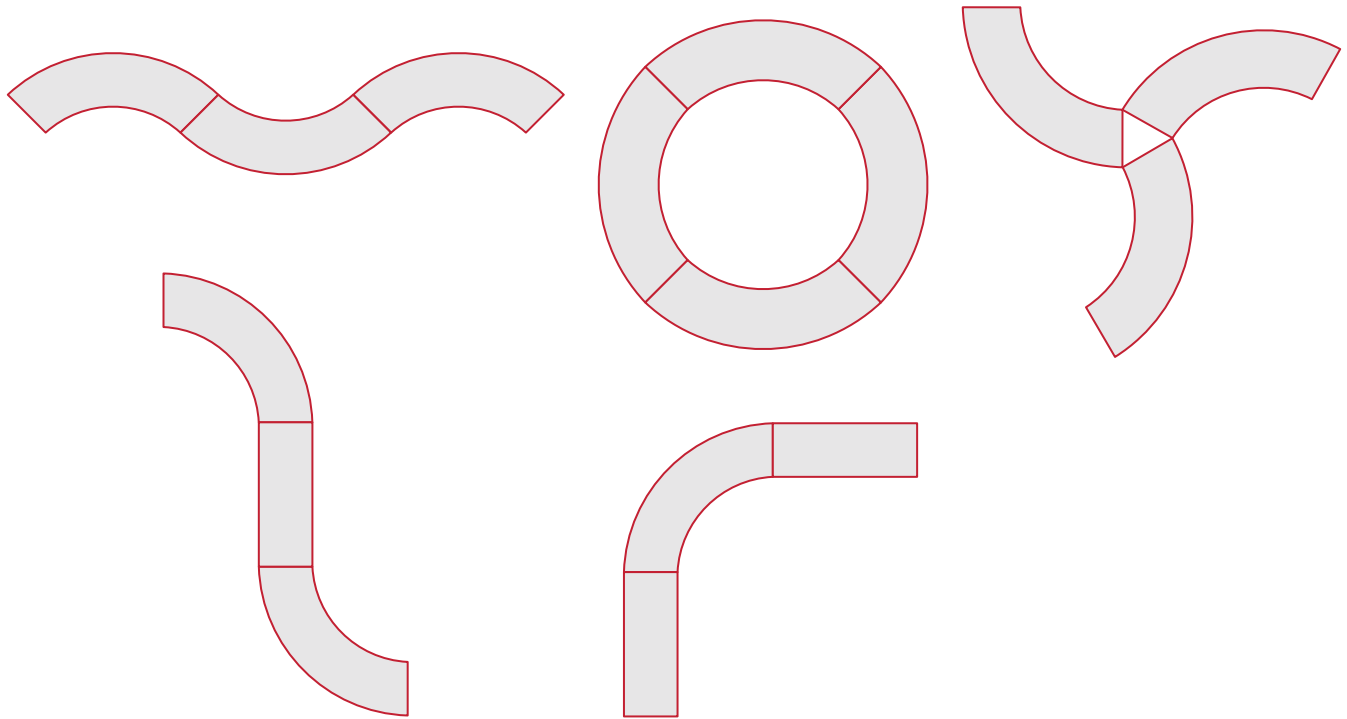

CONFIGURING A MODEL NUMBER

Refer to the Model Numbers and Product Specs section for a list of all family part model numbers in this product line. Use the chart below as a reference for how to properly specify this product.

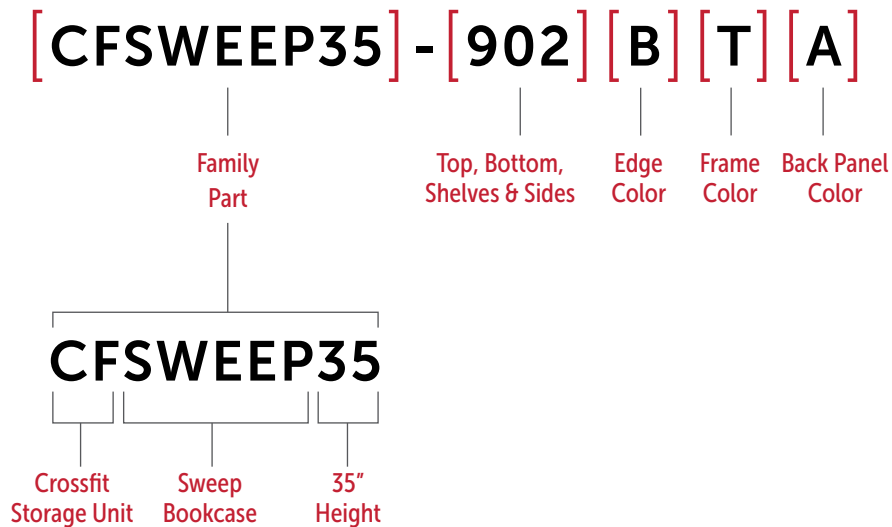

COLOR & FINISH OPTIONS

STEP 1 TOP, BOTTOM, SHELVES & SIDES

Use the number next to the melamine name as the key code for **STEP 1**

[FAMILY] - [TOP, BOTTOM, SHELVES & SIDES]

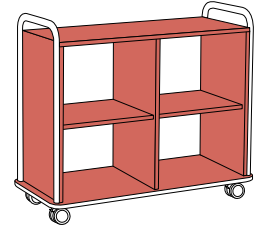
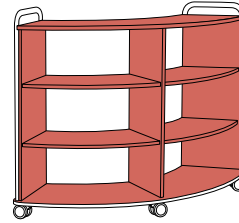

FOLKSTONE
(902)

STEP 2 BOTTOM EDGE

Use the letter next to the edge color name as the key code for **STEP 2**

[FAMILY] - [TOP, BOTTOM, SHELVES & SIDES] [BOTTOM EDGE]

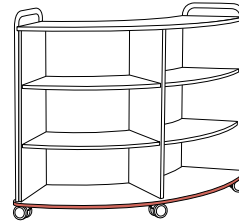

FIRE TRUCK
RED (A)



VANILLA BLUE
(E)



PURPLE
(P)



BLUESCAPE
(U)



BLACK
(B)



GRASS GREEN
(I)



GREEN BEAN
(Q)



ORANGESICLE
(X)



MOD NAVY
(C)



GRAPHITE
(M)



GRAPLE
(R)



LELLO
(Y)



COFFEE
(D)



COOL GRAY
(O)



TANG
(S)



WISDOM
(Z)

STEP 3 FRAME

Choose your frame color. Refer to the Frame Color Key to locate the key code for **STEP 3**

[FAMILY] - [TOP, BOTTOM, SHELVES & SIDES] [BOTTOM EDGE] [FRAME COLOR]



BLACK
(B)



TITANIUM
(T)



WISDOM
(Z)



FLANNEL
(F)



COOL GRAY
(O)



















STEP 4
BACK PANEL

Use the letter next to the paint color name as the key code for **STEP 4**

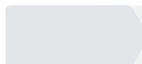

[FAMILY PART] - [TOP, BOTTOM, SHELVES & SIDES] [BOTTOM EDGE] [FRAME COLOR] [BACK PANEL]

 FIRE TRUCK RED (A)	 VANILLA BLUE (E)	 PURPLE (P)	 BLUESCAPE (U)
 BLACK (B)	 GRASS GREEN (I)	 GREEN BEAN (Q)	 ORANGESICLE (X)
 MOD NAVY (C)	 GRAPHITE (M)	 GRAPLE (R)	 LELLO (Y)
 COFFEE (D)	 COOL GRAY (O)	 TANG (S)	 WISDOM (Z)
 FLANNEL (F)	 TITANIUM (T)		

MODEL NUMBERS & PRODUCT SPECS

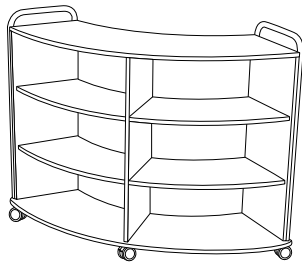

A&D® CROSSFIT SWEEP

Model #	Width (in)	Depth (in)	Height (in)	Weight (lbs)	Freight Class (Qty 1)
CFSWEEP35	65	16.5	38.5	120	150
CFSWEEP45	65	16.5	48.5	160	150

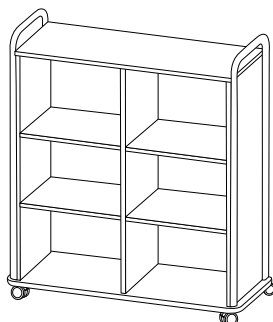

A&D® CROSSFIT DASH

Model #	Width (in)	Depth (in)	Height (in)	Weight (lbs)	Freight Class (Qty 1)
CFDASH35	42	18	38.5	120	150
CFDASH45	42	18	48.5	130	150



INFORMATION COMMONS® SHELVING

Paragon Information Commons single and double faced shelves are designed and manufactured specifically for educational environments. They are flexible, functional, durable, and look great too!

FEATURES

Information Commons or IC shelving is a highly flexible and customizable shelving solution. Each run of shelves begins with a "Starter" and is followed by "Adder" units. Each section requires Side Panels to be ordered separately and the panels are available in several different materials – HPL, Metal, Acrylic.

STRUCTURE

Unique 16-gauge Intuitive 4-post design with hidden cantilever shelving offers clean lines and superior structural strength. Unitized frame structure supports ¾" shelving with smart install single shelf design for double-faced units. Shelf supports for divider accessory are built into adjustable shelves allowing for attractive top shelf display area.

COLOR OPTIONS

Titanium steel with your choice of standard library laminate colors for shelving. Decorative side panels available in complimentary colors.

STYLES

Available in single-face and double-face style with multiple add-ons and options for each.

CABLE WIRE MANAGEMENT

Integrated wire management in base of unit allows for future addition of technology and lighting options.

IC SHELVING WEIGHT CAPACITY (lbs)

	Single	Double
36"	180	360
48"	270	540
60"	360	720
72"	450	900

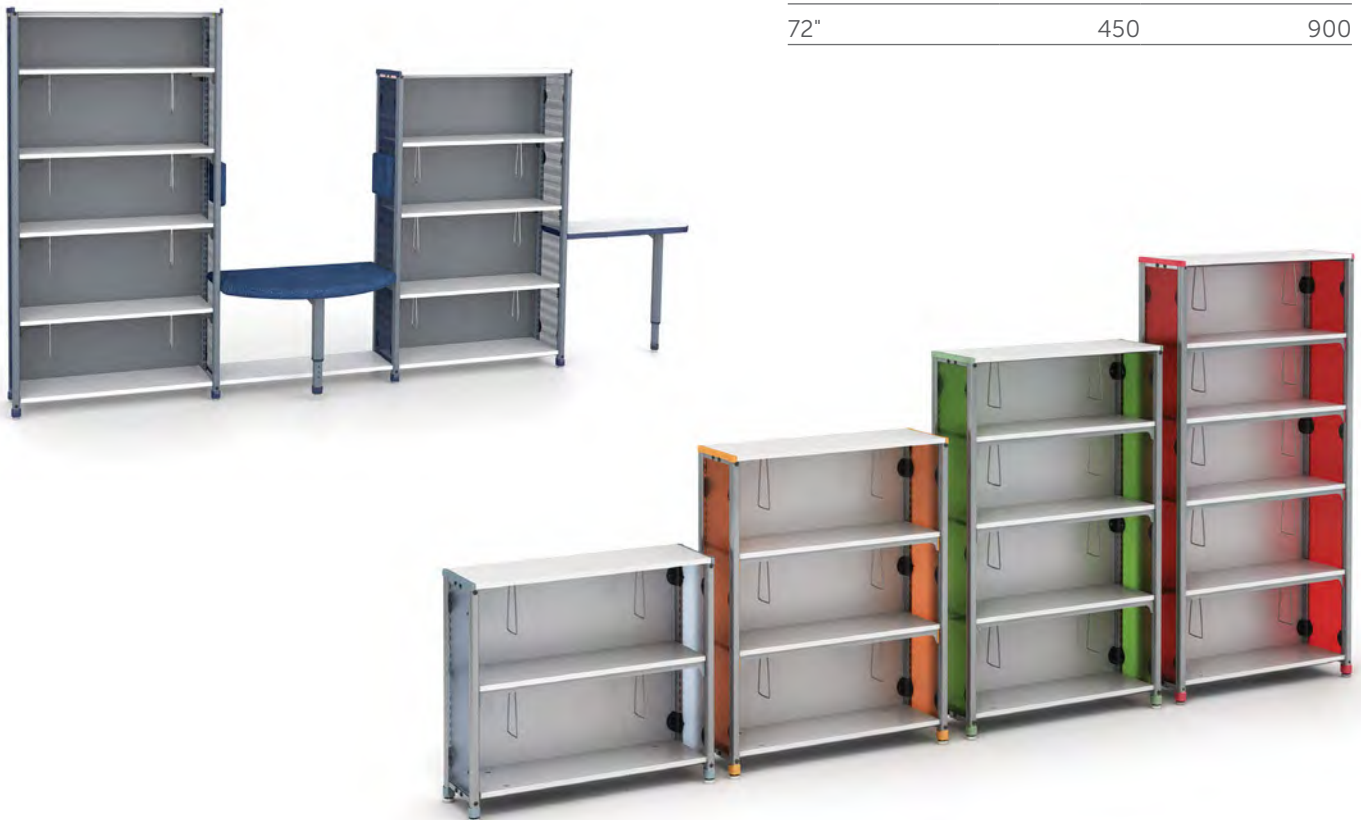

CONFIGURING A MODEL NUMBER

Information Commons® (IC) is configured using a starter/adder concept. When configuring a shelving run, first select a Starter model number. Extend the shelving run by adding additional Adder models. Side Panels are sold separately, and should be added to any Starter/Adder order. Starter models require two Side Panels to be ordered, Adder models require one Side Panel to be order. Lastly, select accessories like tables and benches to achieve the ultimate experience for your library. In this example, we used part **ICD60**. The structure of this new part number can be broken up with parenthesis like this:

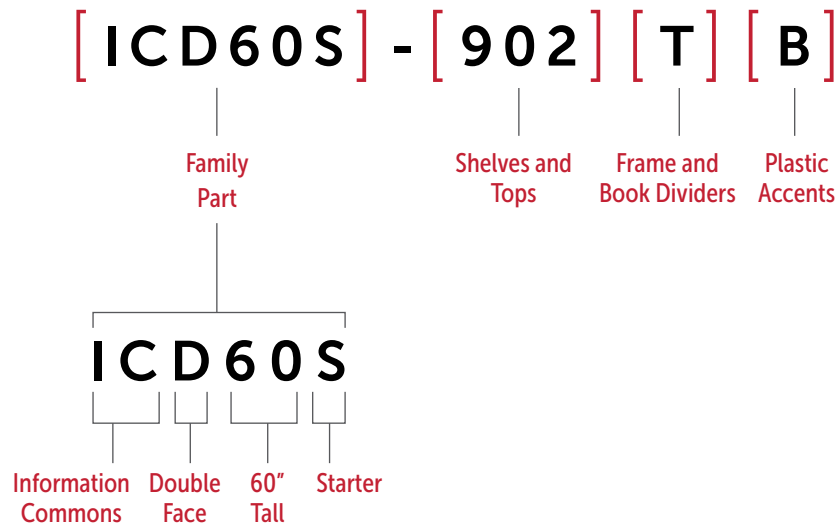

COLOR & FINISH OPTIONS

STEP 1 SHELVES & TOPS

Shelves and Tops are finished in same color. Select one color from the pallet below to represent both areas.

[**FAMILY PART**] - [**SHELVES & TOPS**]

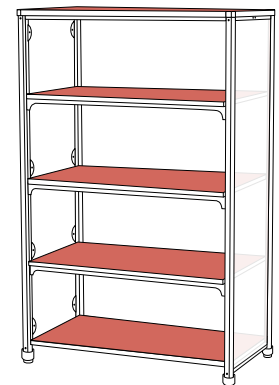

BLACK
(900)



RIVER
CHERRY (566)



FROST
(918)



KENSINGTON
MAPLE (963)



XANADU
(110)



STUDIO
TEAK (103)



FOLKSTONE
(902)

STEP 2
FRAME & BOOK
DIVIDERS

[FAMILY] - [SHELVES] [FRAME]
[PART] - [& TOPS]

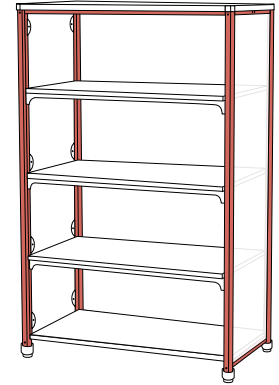

STEP 3
PLASTIC ACCENTS

[FAMILY] - [SHELVES] [FRAME] [PLASTIC]
[PART] - [& TOPS] [ACCENTS]

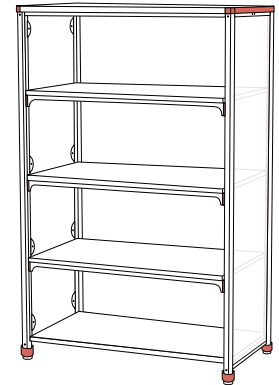

ADD-ONS

SIDE PANELS & BACK PANELS

All Side and Back Panels for IC Shelving units are sold separately with independent model numbers. Back Panels can only be added to Single Face units. Side Panels and Back Panels can be specified in HPL, Metal, or Acrylic in the following colors:

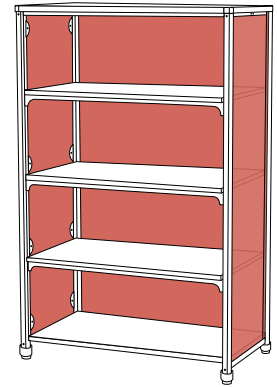

LAMINATE COLORS

SOLID LAMINATE

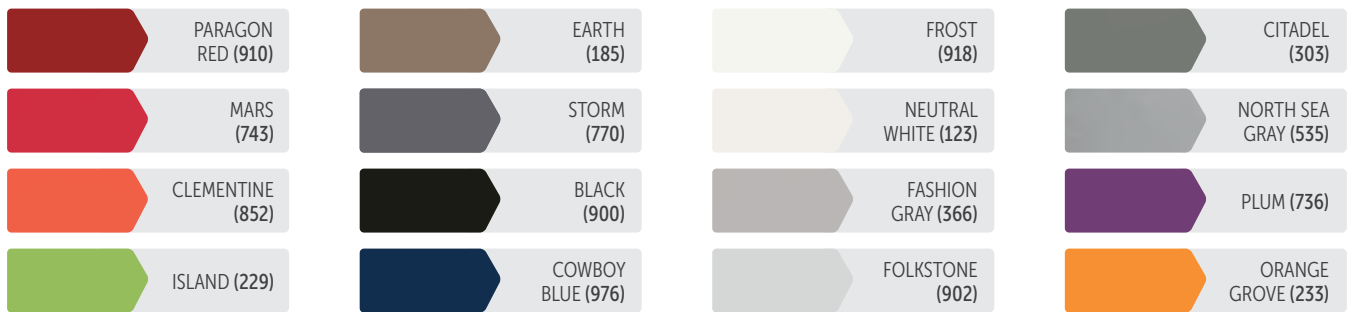

WHITEBOARD LAMINATE



WOOD GRAIN LAMINATE

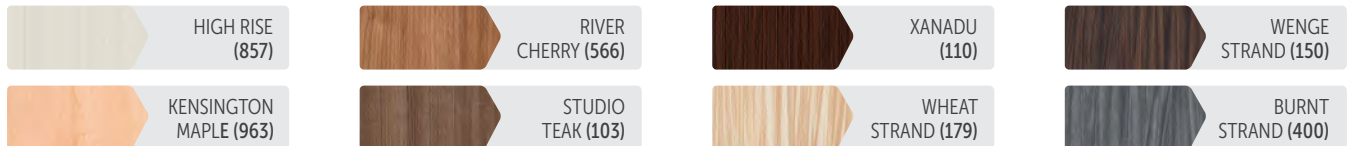

PATTERN LAMINATE



NEW COLORS

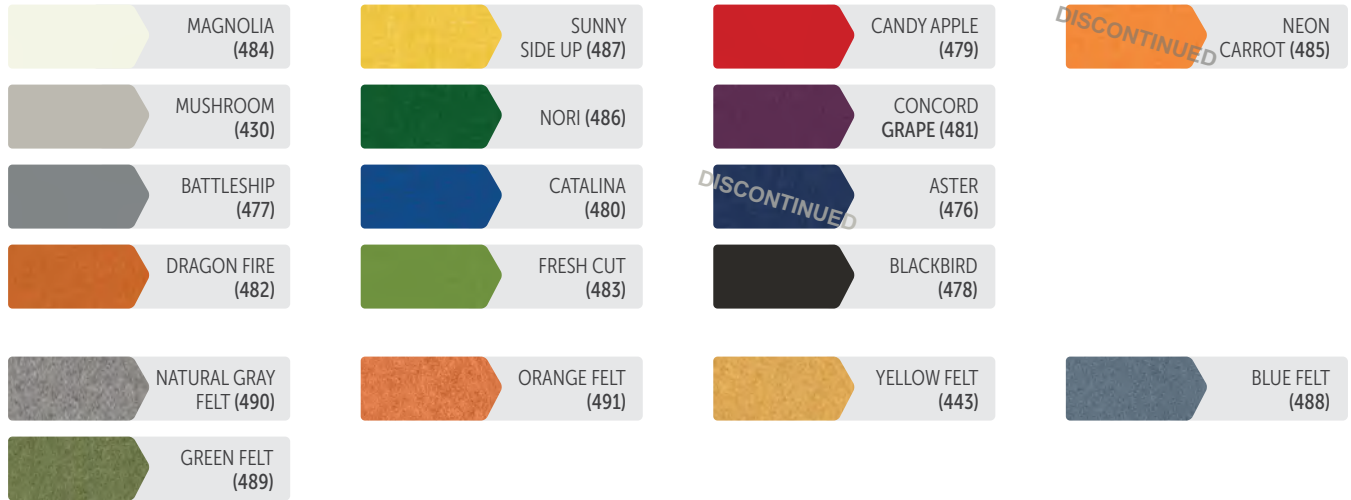

METAL COLORS

Metal Color Key: Note that the last character of these key codes is the same character used in the metal color key.

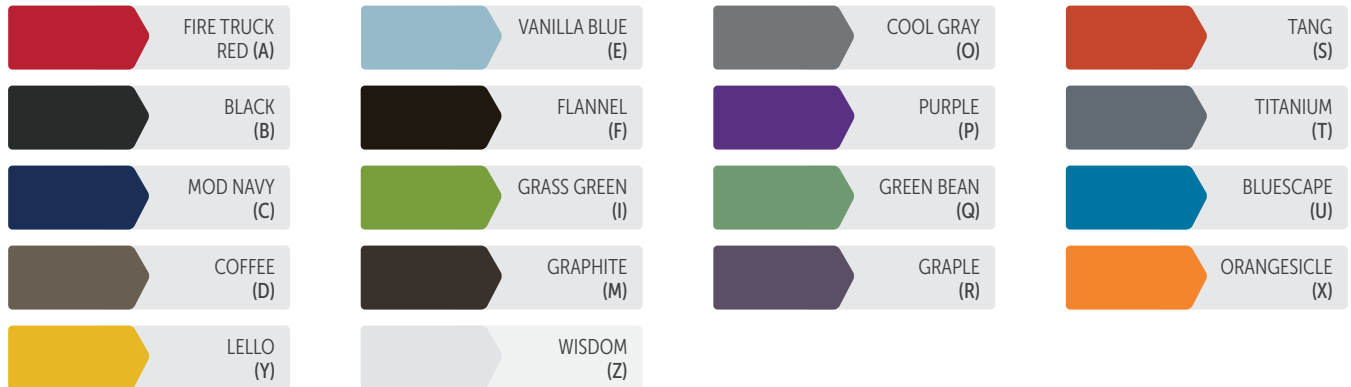

ACRYLIC COLORS

Acrylic Color Key: There are 13 acrylic colors available that are represented by numbers between 01-13.

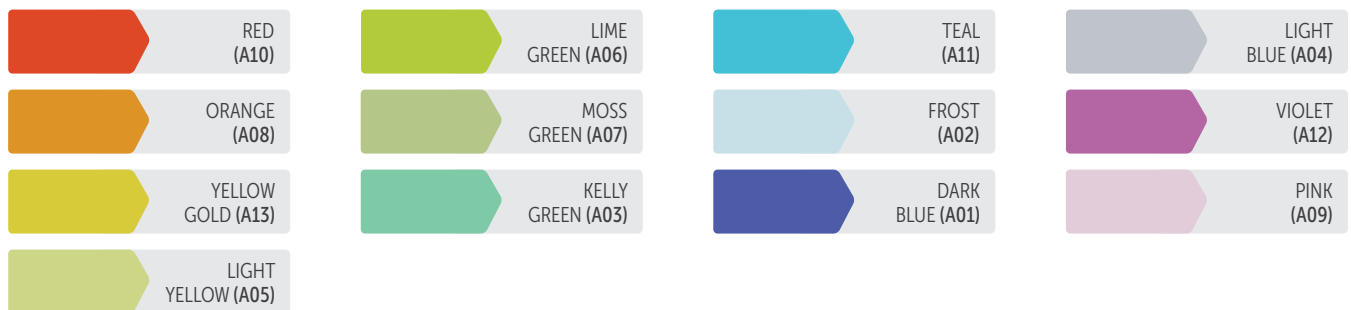

ADD-ONS

TABLES (OPTIONAL)

Optional Tables in different shapes & positions can be added to IC Shelving units. Tables are ordered separately with their own model numbers. Tables can be specified in HPL in the following colors:

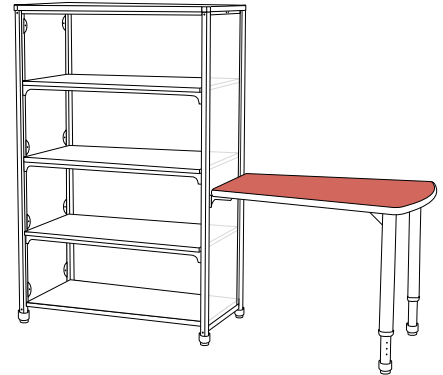

STEP 1 TABLE LAMINATE COLORS

SOLID LAMINATE

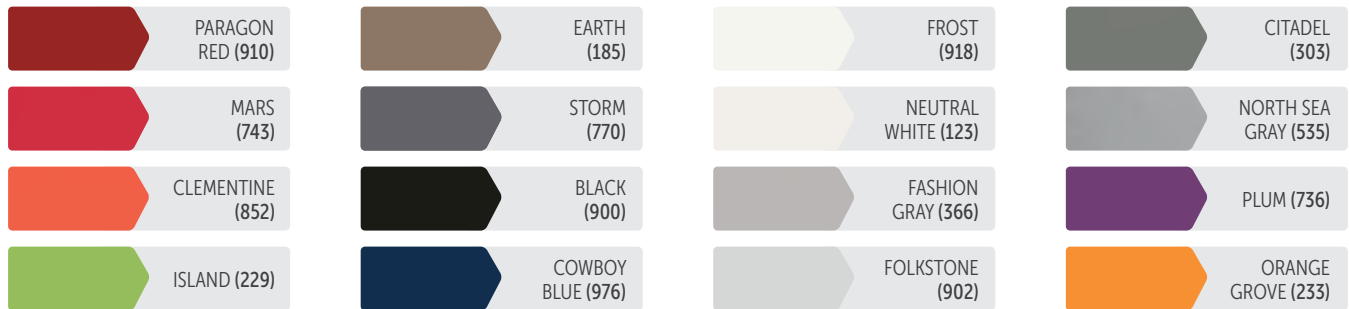

WHITEBOARD LAMINATE



WOOD GRAIN LAMINATE

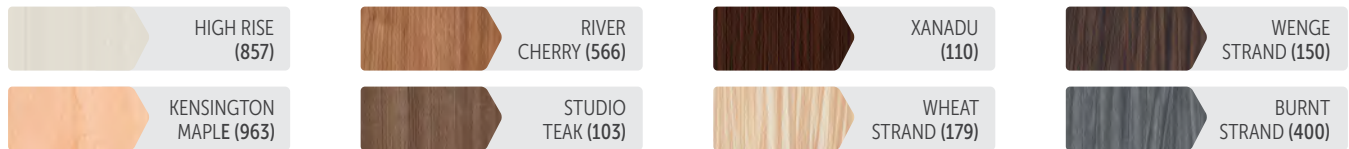

PATTERN LAMINATE



NEW COLORS

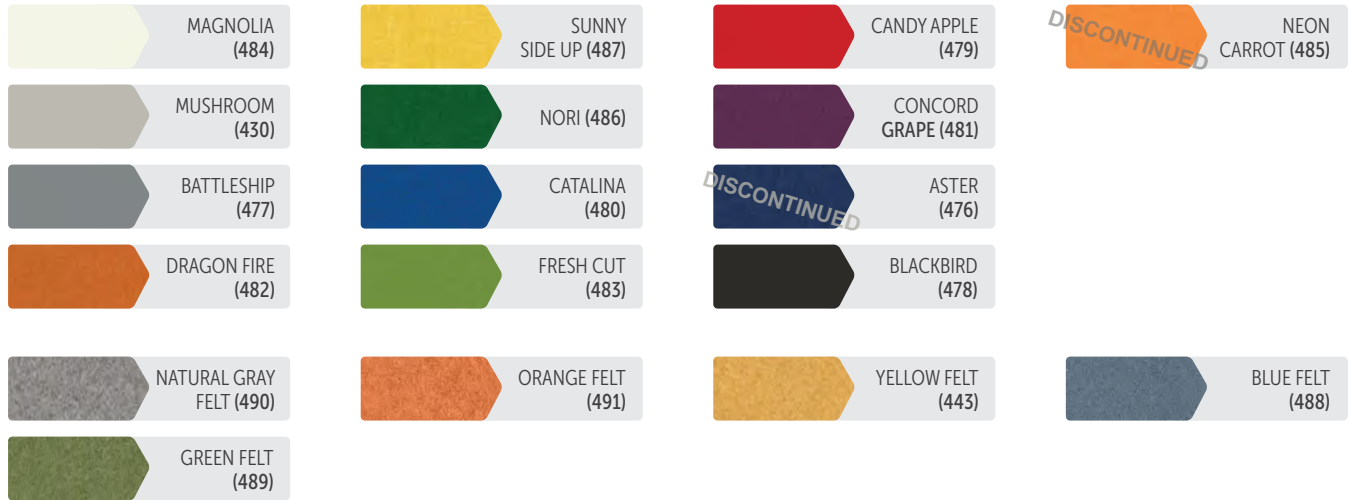

STEP 2
TABLE EDGE
COLORS

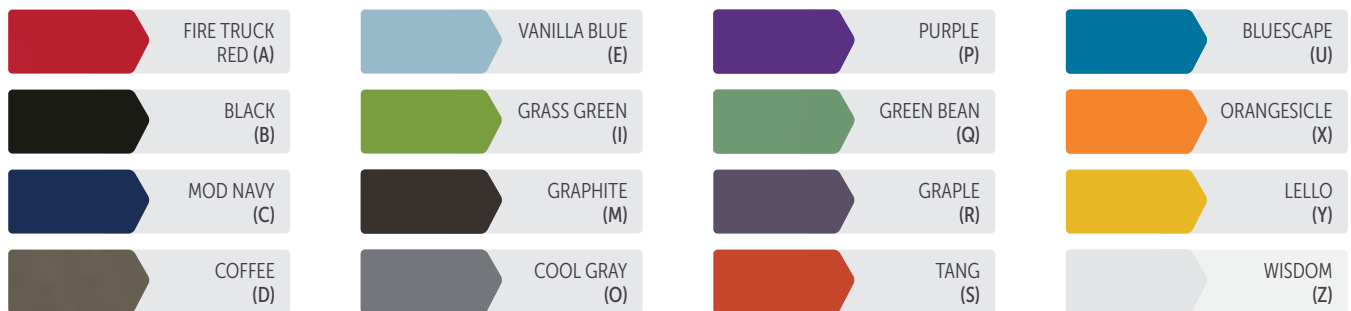
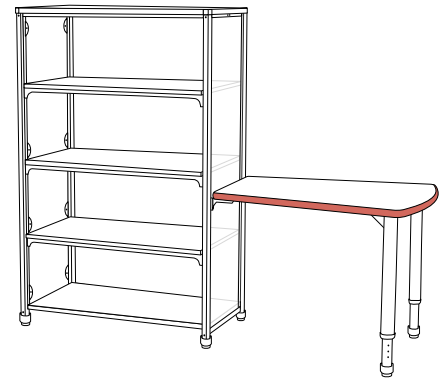

STEP 3
TABLE LEG
COLORS

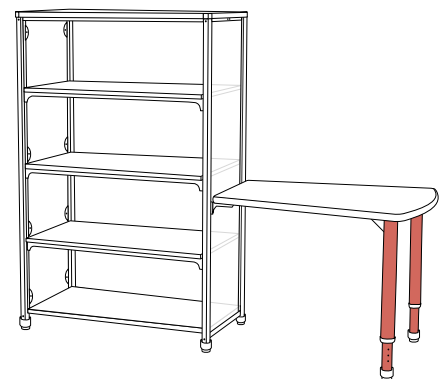

BENCHES (OPTIONAL)

Optional Benches in different shapes & positions can be added to IC Shelving units. Benches are ordered separately with their own model numbers. Benches can be specified in Momentum or Spradling textiles in the following colors:

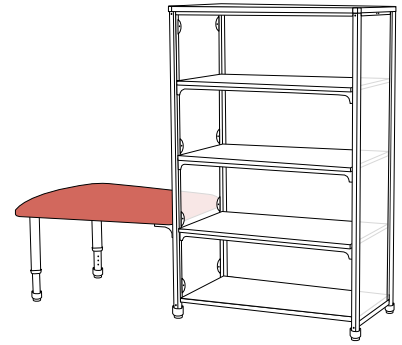

STEP 1 BENCH TEXTILES

MAYER QUATTRO PATTERN SERIES

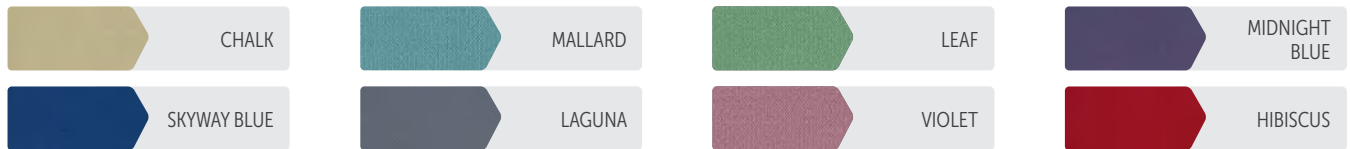

CF STINSON LARA PATTERN SERIES

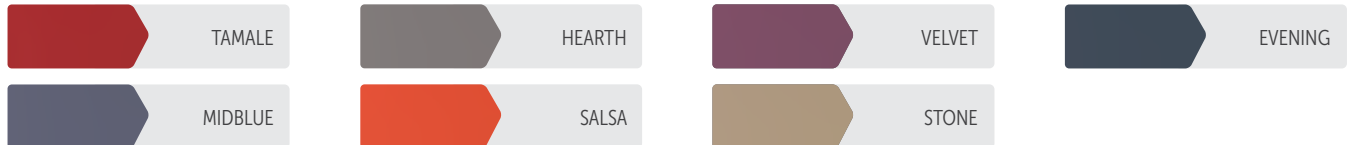

MOMENTUM EVO CV



MOMENTUM TRIBECA CV



MOMENTUM VANGUARD CV



SPRADLING EDGELINE PATTERN SERIES

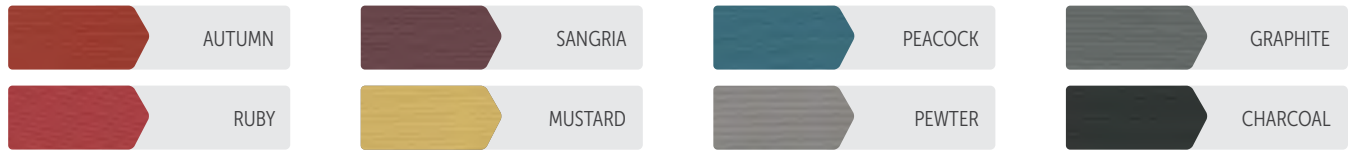

SPRADLING SILVERTEX PATTERN SERIES

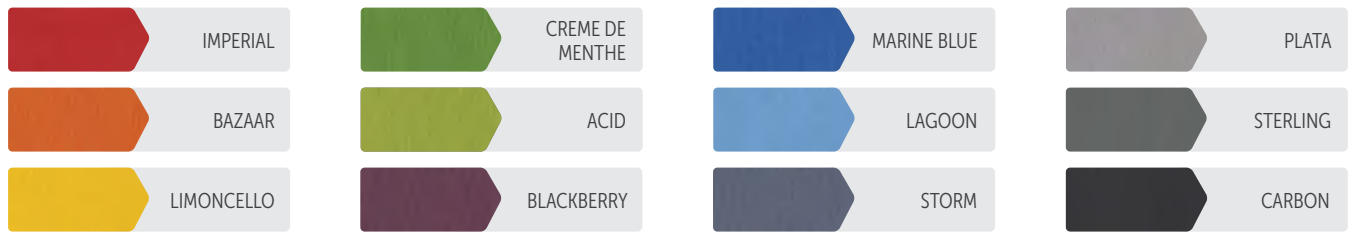

GRADED-IN PROGRAM

Soft seating is also available in hundreds of additional textiles through our graded-in program.

Scan the QR code or visit paragoninc.com/textiles for details.

If you have a custom fabric you'd like to use, we also offer a COM option. Contact us for additional information.



STEP 2 BENCH LEG COLOR

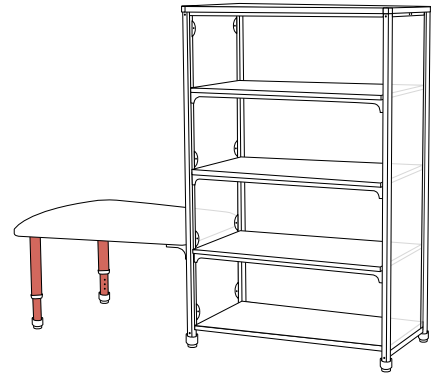

MODEL NUMBERS & PRODUCT SPECS

IC-SINGLE STARTER

Model #	Width (in)	Depth (in)	Height (in)	Weight (lbs)	Freight Class (Qty 1)
IC-S36S (2 Shelves)	38	12	36	125	85
IC-S48S (3 Shelves)	38	12	48	135	85
IC-S60S (4 Shelves)	38	12	60	140	85
IC-S72S (5 Shelves)	38	12	72	155	85

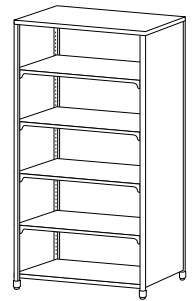

IC-SINGLE ADDER

Model #	Width (in)	Depth (in)	Height (in)	Weight (lbs)	Freight Class (Qty 1)
IC-S36A (2 Shelves)	36	12	36	120	85
IC-S48A (3 Shelves)	36	12	48	125	85
IC-S60A (4 Shelves)	36	12	60	130	85
IC-S72A (5 Shelves)	36	12	72	145	85

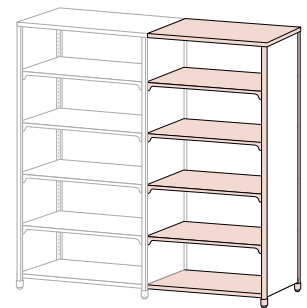

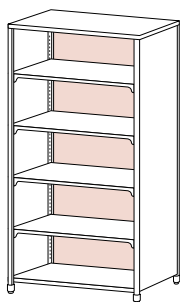

IC-SINGLE BACK PANELS

Model #	Width (in)	Depth (in)	Height (in)	Weight (lbs)	Freight Class (Qty 1)
IC-36BP	35.25	N/A	34.75	15	85
IC-36BP-ACRYLIC	35.25	N/A	34.75	15	85
IC-36BP-M	35.25	N/A	34.75	15	85
IC-48BP	35.25	N/A	45.75	20	85
IC-48BP-ACRYLIC	35.25	N/A	45.75	20	85
IC-48BP-M	35.25	N/A	45.75	20	85
IC-60BP	35.25	N/A	58.75	25	85
IC-60BP-ACRYLIC	35.25	N/A	58.75	25	85
IC-60BP-M	35.25	N/A	58.75	25	85
IC-72BP	35.25	N/A	70.75	30	85
IC-72BP-ACRYLIC	35.25	N/A	70.75	30	85
IC-72BP-M	35.25	N/A	70.75	30	85

M = Metal

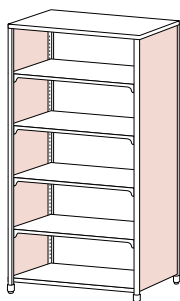

IC-SINGLE SIDE PANELS (Sold as single panel, not pairs)

Model #	Width (in)	Depth (in)	Height (in)	Weight (lbs)	Freight Class (Qty 1)
IC-36SSP	8.5	N/A	33.25	10	85
IC-36SSP-ACRYLIC	8.5	N/A	33.25	10	85
IC-36SSP-M	8.5	N/A	33.25	10	85
IC-48SSP	8.5	N/A	45.25	15	85
IC-48SSP-ACRYLIC	8.5	N/A	45.25	15	85
IC-48SSP-M	8.5	N/A	45.25	15	85
IC-60SSP	8.5	N/A	57.25	20	85
IC-60SSP-ACRYLIC	8.5	N/A	57.25	20	85
IC-60SSP-M	8.5	N/A	57.25	20	85
IC-72SSP	8.5	N/A	69.25	20	85
IC-72SSP-ACRYLIC	8.5	N/A	69.25	20	85
IC-72SSP-M	8.5	N/A	69.25	20	70

M = Metal

IC-SINGLE TABLES

Model #	Width (in)	Depth (in)	Height (in)	Weight (lbs)	Freight Class (Qty 1)
IC-S-INRUN-60REC	35	60	24.5 - 35.5	130	85
IC-S-INRUN-60T	35	60	24.5 - 35.5	130	85
IC-S-ENDOFRUN-36	37	13	24.5 - 35.5	120	85

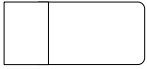

REC = Rectangle

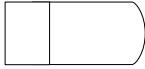

T= Tombstone

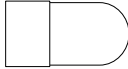

ENDOFRUN-36



IC-SINGLE BENCH

Model #	Width (in)	Depth (in)	Height (in)	Weight (lbs)	Freight Class (Qty 1)
IC-S-INRUNBENCH	35	21.5	17 - 21	70	85
IC-S-ENDOFRUNBENCH	35	21.5	17 - 21	50	85
IC-S-BACKCUSHION	8	2	8.5	10	85

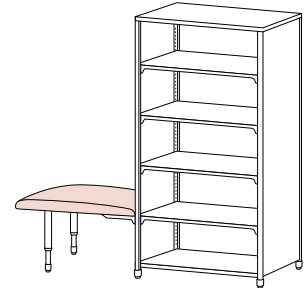

IC-DOUBLE STARTER

Model #	Width (in)	Depth (in)	Height (in)	Weight (lbs)	Freight Class (Qty 1)
IC-D48S (3 Shelves)	38	20.5	48	140	85
IC-D60S (4 Shelves)	38	20.5	60	160	85
IC-D72S (5 Shelves)	38	20.5	72	180	85

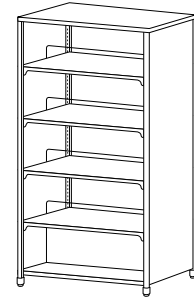

IC-DOUBLE ADDER

Model #	Width (in)	Depth (in)	Height (in)	Weight (lbs)	Freight Class (Qty 1)
IC-D48A (3 Shelves)	36	20.5	48	135	85
IC-D60A (4 Shelves)	36	20.5	60	150	85
IC-D72A (5 Shelves)	36	20.5	72	165	85

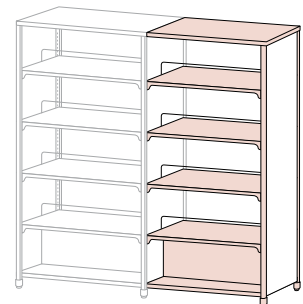

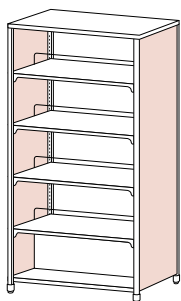

IC-DOUBLE SIDE PANELS (Sold as single panel, not pairs)

Model #	Width (in)	Depth (in)	Height (in)	Weight (lbs)	Freight Class (Qty 1)
IC-48DSP	17.25	N/A	45.25	20	85
IC-48DSP-ACRYLIC	17.25	N/A	45.25	20	85
IC-48DSP-M	17.25	N/A	45.25	20	85
IC-60DSP	17.25	N/A	57.25	25	85
IC-60DSP-ACRYLIC	17.25	N/A	57.25	25	85
IC-60DSP-M	17.25	N/A	57.25	25	85
IC-72DSP	17.25	N/A	69.25	30	85
IC-72DSP-ACRYLIC	17.25	N/A	69.25	30	85
IC-72DSP-M	17.25	N/A	69.25	30	85

M = Metal

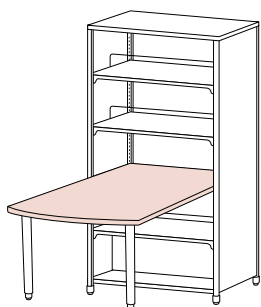

IC-DOUBLE TABLES

Model #	Width (in)	Depth (in)	Height (in)	Weight (lbs)	Freight Class (Qty 1)
IC-D-INRUN-60REC	35	60	24.5 - 35.5	130	85
IC-D-INRUN-60T	35	60	24.5 - 35.5	130	85
IC-D-ENDOFRUN-36	29	36	24.5 - 35.5	120	85



REC = Rectangle



T = Tombstone

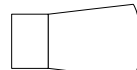

ENDOFRUN-36

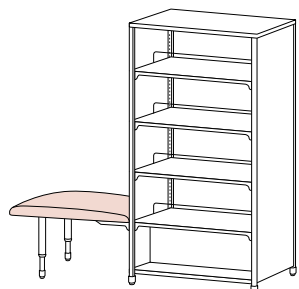

IC-DOUBLE BENCH

Model #	Width (in)	Depth (in)	Height (in)	Weight (lbs)	Freight Class (Qty 1)
IC-D-INRUNBENCH	35	20	17 - 21	130	85
IC-D-ENDOFRUNBENCH	34	20	17 - 21	130	85
IC-D-BACKCUSHION	17.25	2	8.5	10	85

SHELF ACCESSORIES

Model #	Width (in)	Depth (in)	Height (in)	Weight (lbs)	Freight Class (Qty 1)
IC-SEISMIC-A	2	2.87	3	5	85
IC-SEISMIC-S	2	2.87	3	5	85
IC-VIDEOSHELF	35	11	11	20	85
IC-PERIODICAL	35	10	10.5	20	85
IC-SINGLE-SHELF	35	20	1	20	85
IC-DOUBLE-SHELF	35	11	1	30	85



INFORMATION COMMONS® MOBILE SHELVING

Mobile shelving solution designed for easy transportation and storage of books, supplies, and other equipment. Perfect for classrooms, makerspaces, libraries, and anywhere else at school.

FEATURES

Paragon IC Mobile Shelving units are designed and manufactured specifically for educational environments. They are flexible, functional, durable, and look great too!

STRUCTURE

Unique 16-gauge Intuitive 4-post design with unitized frame structure for superior strength and durability. 3/4" adjustable shelving with steel supports to accommodate different sized books and storage items.

CASTERS

All IC Mobile Shelving is equipped with 4 smooth rolling casters with locking mechanisms to move easily when in motion and lock firmly in place when stationary.

COLORS

Titanium steel colored frame with standard library laminate choices for shelves. Side panels are available in multiple colors with choice of material: HPL, Metal, and Acrylic.



CONFIGURING A MODEL NUMBER

Refer to the Model Numbers & Product Specs section for a list of all family part model numbers in this product line. Use the chart below as a reference for how to properly specify this product.

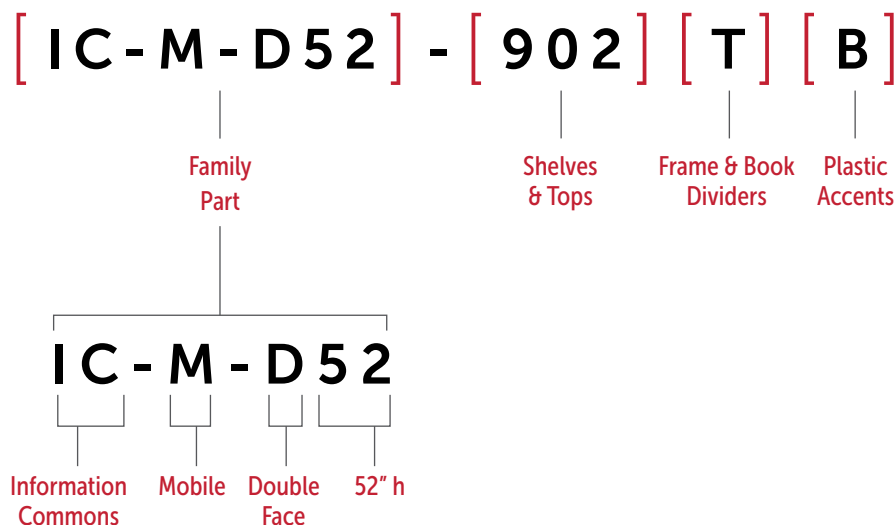

COLOR & FINISH OPTIONS

STEP 1
SHELVES &
TOPS

Shelves & Tops are finished in same color. Select one color from the pallet below to represent both areas.

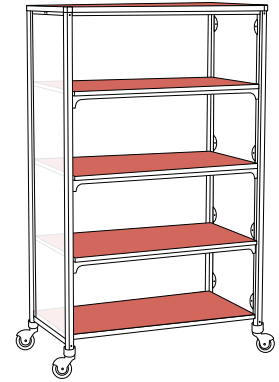

[FAMILY] - [SHELVES &]
 [PART] - [TOP]

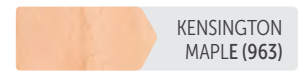
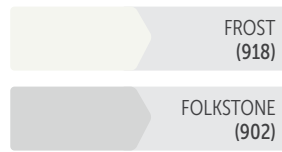
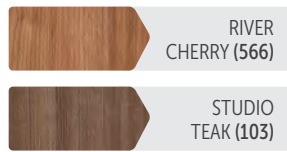
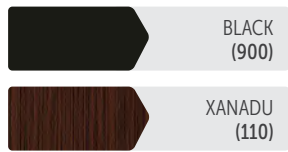

STEP 2
FRAME BOOK
DIVIDERS

[FAMILY] - [SHELVES &] [FRAME BOOK]
 [PART] - [TOP] [DIVIDERS]

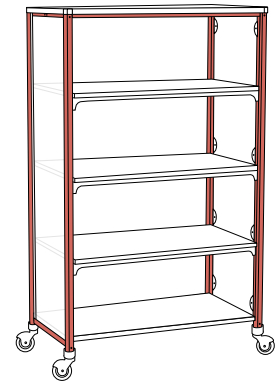





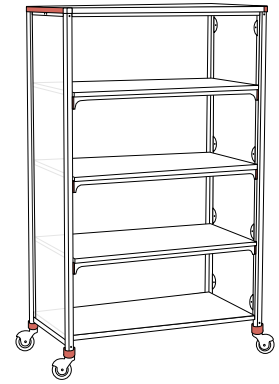









STEP 3 PLASTIC ACCENTS

Choose your accent color. Refer to the Accent Color Key to locate the key code for STEP 3

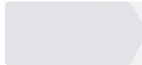

[FAMILY PART] - [SHELVES & TOP] [FRAME BOOK DIVIDERS] [PLASTIC ACCENTS]

 FIRE TRUCK RED (A)	 VANILLA BLUE (E)	 PURPLE (P)	 BLUESCAPE (U)
 BLACK (B)	 GRASS GREEN (I)	 GREEN BEAN (Q)	 ORANGESICLE (X)
 MOD NAVY (C)	 GRAPHITE (M)	 GRAPLE (R)	 LELLO (Y)
 COFFEE (D)	 COOL GRAY (O)	 TANG (S)	 WISDOM (Z)

ADD-ONS





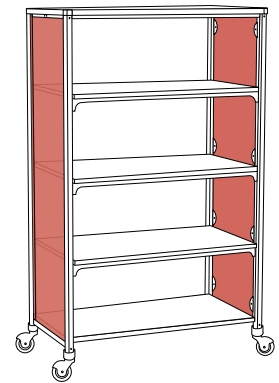











SIDE PANELS

All Side Panels for IC Mobile Shelving units are sold separately with independent model numbers. Side Panels can be specified in HPL, Metal, or Acrylic in the following colors:



LAMINATE COLORS

SOLID LAMINATE

 PARAGON RED (910)	 EARTH (185)	 FROST (918)	 CITADEL (303)
 MARS (743)	 STORM (770)	 NEUTRAL WHITE (123)	 NORTH SEA GRAY (535)
 CLEMENTINE (852)	 BLACK (900)	 FASHION GRAY (366)	 PLUM (736)
 ISLAND (229)	 COWBOY BLUE (976)	 FOLKSTONE (902)	 ORANGE GROVE (233)

WHITEBOARD LAMINATE



WOOD GRAIN LAMINATE

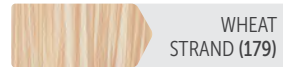
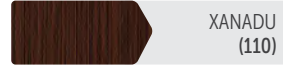
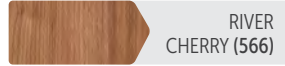

PATTERN LAMINATE

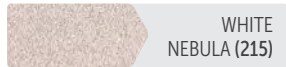

NEW COLORS

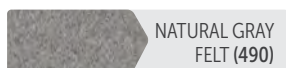

METAL COLORS

Metal Color Key: Note that the last character of these key codes is the same character used in the metal color key.

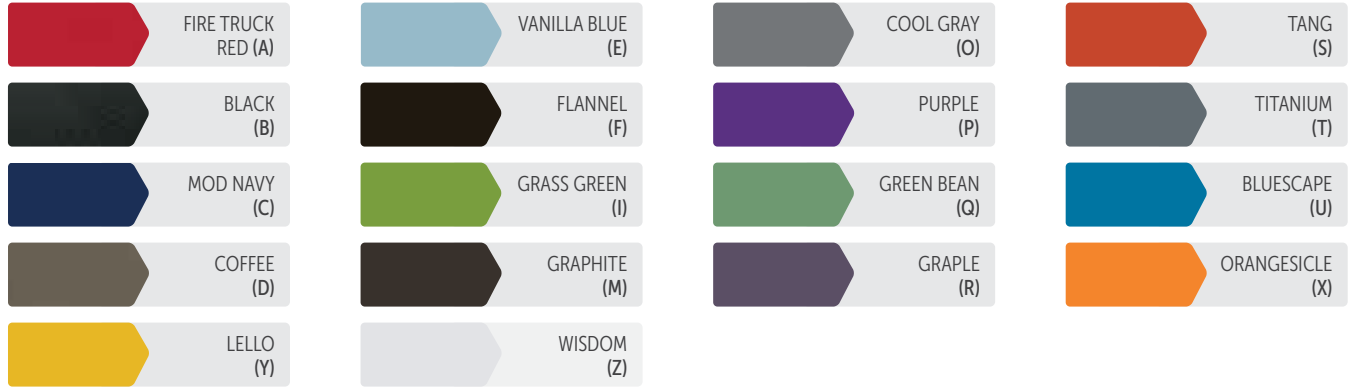

ACRYLIC COLORS

Acrylic Color Key: There are 13 acrylic colors available that are represented by numbers between 01-13.

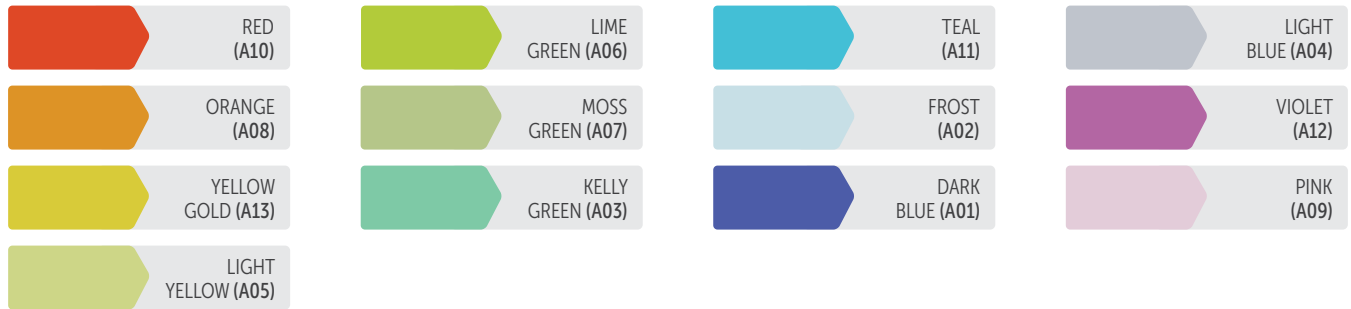

MODEL NUMBERS & PRODUCT SPECS

IC-MOBILE DOUBLE FACE SHELVING

Model #		Width (in)	Depth (in)	Height (in)	Weight (lbs)	Freight Class (Qty 1)
IC-M-D52	3 Shelves	38	20.5	52	150	150
IC-M-D64	4 Shelves	38	20.5	64	170	150

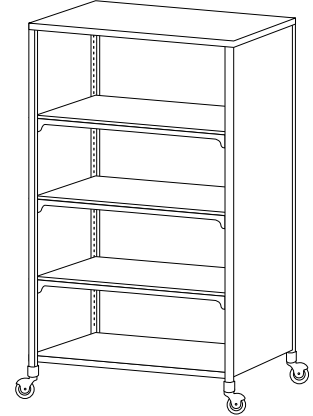

IC-DOUBLE SIDE PANELS (Sold as single panel, not pairs)

Model #	Width (in)	Depth (in)	Height (in)	Weight (lbs)	Freight Class (Qty 1)
IC-48DSP	17.25	N/A	45.25	20	85
IC-48DSP-ACRYLIC	17.25	N/A	45.25	20	85
IC-48DSP-M	17.25	N/A	45.25	20	85
IC-60DSP	17.25	N/A	57.25	25	85
IC-60DSP-ACRYLIC	17.25	N/A	57.25	25	85
IC-60DSP-M	17.25	N/A	57.25	25	85

M = Metal

Choose IC-48D Side panels for IC-M-52 Mobile Shelving

Choose IC-60D Side panels for IC-M-64 Mobile Shelving

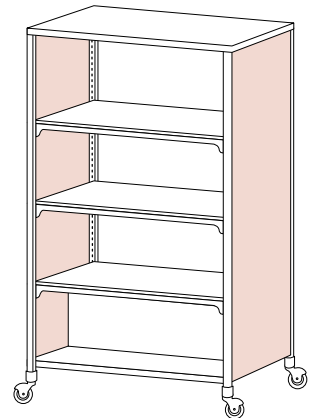



INFORMATION COMMONS® MOBILE CART

IC Mobile Storage Carts designed for easy transportation of books, supplies, and other equipment. Perfect for classrooms, makerspaces, libraries, and anywhere else at school.

FEATURES

Paragon IC Mobile Carts are designed & manufactured specifically for educational environments. They are flexible, functional, durable, and look great too!

STRUCTURE

Durable titanium steel frame construction with 3-2 Connect die-cast aluminum joints for ultimate strength. ¾" melamine top with 3mm edge. Optional end panels available in ¼" MDF HPL, perforated colored powder-coated steel, or acrylic. Shaped steel reverse cantilever bracket allows for shelf height adjustment. 5" super heavy-duty casters allow for ease of motion over many different types of interior surfaces.

OPTIONS

The IC Mobile Cart can be configured in numerous ways to meet your specific needs. Cart can be configured with or without doors, side panels, back panels and in different sizes.



CONFIGURING A MODEL NUMBER

Refer to the Model Numbers and Product Specs section for a list of all family part model numbers in this product line. Use the chart below as a reference for how to properly specify this product.

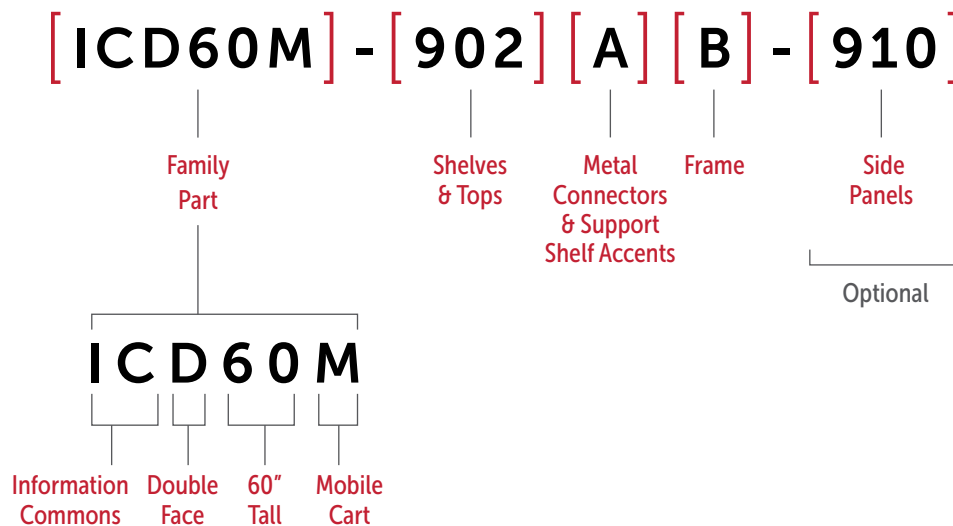





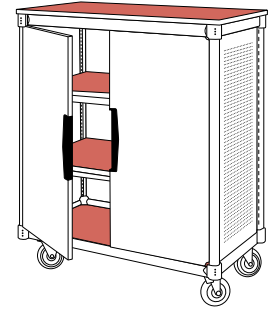

COLOR & FINISH OPTIONS

STEP 1
SHELVES &
TOPS

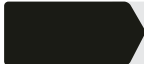
Shelves & Tops are finished in same color. Select one color from the pallet below to represent both areas

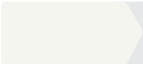

[FAMILY] - [SHELVES & TOP]
[PART]

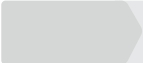





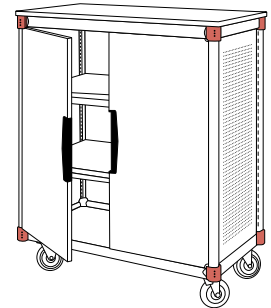









 BLACK (900)	 RIVER CHERRY (566)	 FROST (918)	 KENSINGTON MAPLE (963)
 XANADU (110)	 STUDIO TEAK (103)	 FOLKSTONE (902)	

STEP 2
METAL
CONNECTORS

Choose accent colors for metal connectors

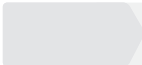
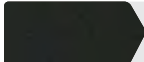

[FAMILY] - [SHELVES & TOP] [ACCENT COLOR]
[PART]

 FIRE TRUCK RED (A)	 VANILLA BLUE (E)	 PURPLE (P)	 BLUESCAPE (U)
 BLACK (B)	 GRASS GREEN (I)	 GREEN BEAN (Q)	 ORANGESICLE (X)
 MOD NAVY (C)	 GRAPHITE (M)	 GRAPLE (R)	 LELLO (Y)
 COFFEE (D)	 COOL GRAY (O)	 TANG (S)	 WISDOM (Z)
 FLANNEL (F)	 TITANIUM (T)		

STEP 3 FRAME

Choose your frame color. Refer to the Frame color key to locate the key code for **STEP 3**

[FAMILY] - [SHELVES &] [ACCENT] [FRAME]
[PART] - [TOP] [COLOR] [COLOR]

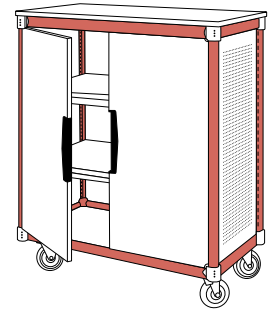

STEP 4 SIDES PANELS (OPTIONAL)

Sides panels are available in laminate, metal & acrylic. Refer to the Sides panels color key to locate the key code for **STEP 4**

[FAMILY] - [SHELVES &] [ACCENT] [FRAME] - [SIDE]
[PART] - [TOP] [COLOR] [COLOR] [PANELS]

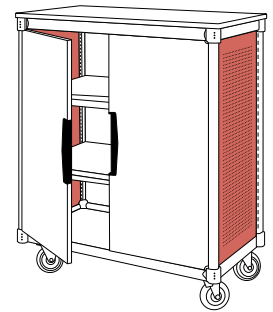

LAMINATE COLORS

SOLID LAMINATE

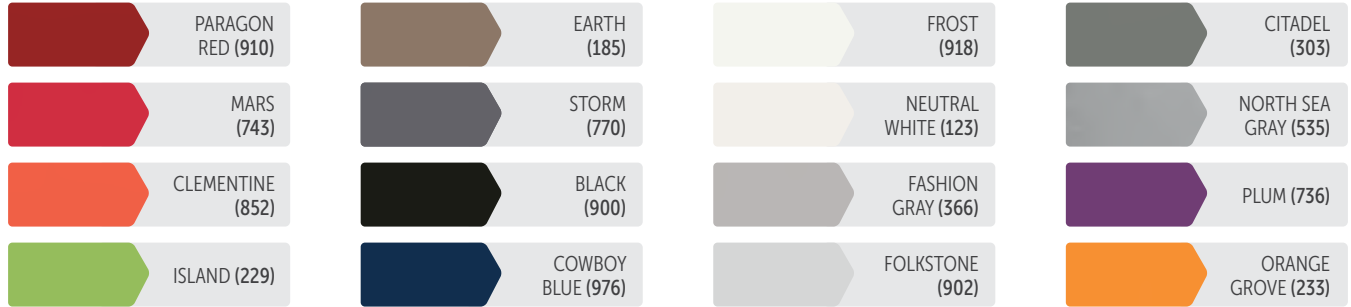

WHITEBOARD LAMINATE



WOOD GRAIN LAMINATE

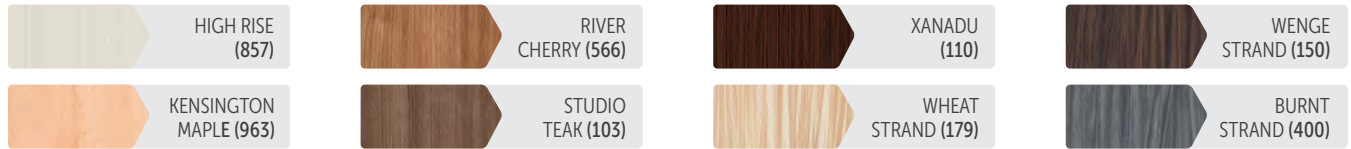

PATTERN LAMINATE



NEW COLORS



METAL COLORS

Metal Color Key: Note that the last character of these key codes is the same character used in the metal color key.

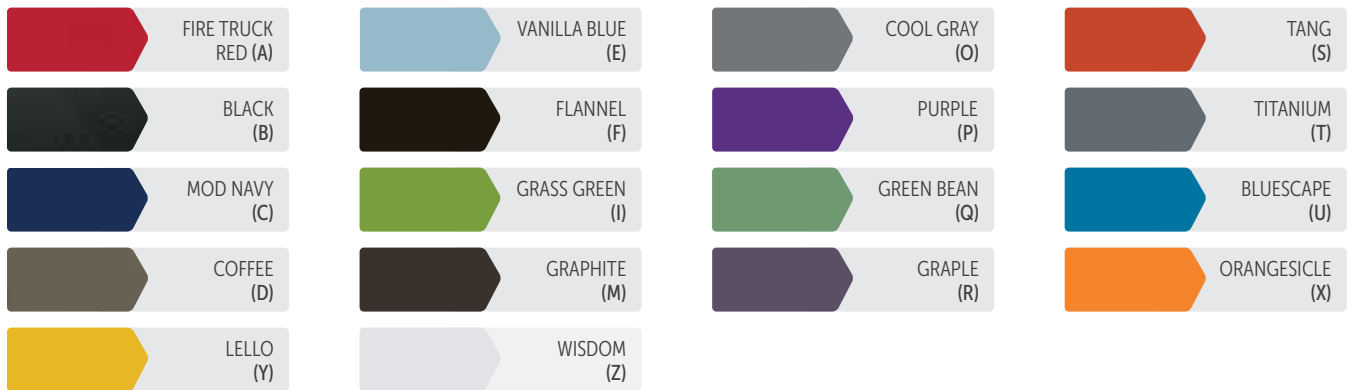

ACRYLIC COLORS

Acrylic Color Key: There are 13 acrylic colors available that are represented by numbers between 01-13.

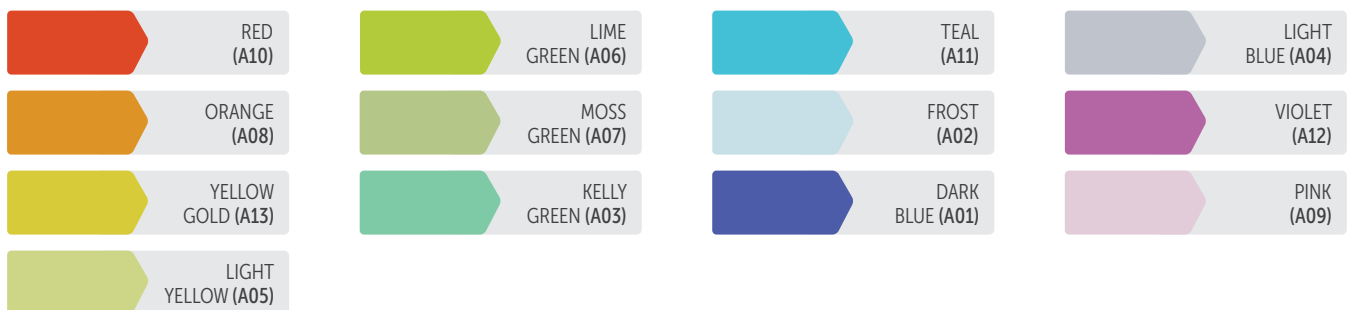

MODEL NUMBERS & PRODUCT SPECS

46" IC MOBILE CARTS

Model #	Width (in)	Depth (in)	Height (in)	Weight (lbs)	Freight Class (Qty 1)
ICD46M-SL-00-00	39	21	47	280	150
ICD46M-SM-00-00	39	21	47	280	150
ICD46M-SA-00-00	39	21	47	280	150
ICD46M-00-00-00	39	21	47	240	150
ICD46M-SL-BL-DL	39	21	47	320	150
ICD46M-SL-BM-DL	39	21	47	320	150
ICD46M-SL-BA-DL	39	21	47	320	150
ICD46M-SM-BL-DL	39	21	47	320	150
ICD46M-SM-BM-DL	39	21	47	320	150
ICD46M-SM-BA-DL	39	21	47	320	150
ICD46M-SA-BL-DL	39	21	47	320	150
ICD46M-SA-BM-DL	39	21	47	320	150
ICD46M-SA-BA-DL	39	21	47	320	150

ICD46M Includes 2 Shelves L = Laminate M = Metal A = Acrylic

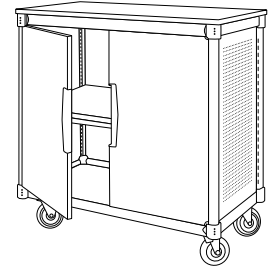

60" IC MOBILE CARTS

Model #	Width (in)	Depth (in)	Height (in)	Weight (lbs)	Freight Class (Qty 1)
ICD60M-SL-00-00	39	21	57.5	310	150
ICD60M-SM-00-00	39	21	57.5	310	150
ICD60M-SA-00-00	39	21	57.5	310	150
ICD60M-00-00-00	39	21	57.5	260	150
ICD60M-SL-BL-DL	39	21	57.5	360	150
ICD60M-SL-BM-DL	39	21	57.5	360	150
ICD60M-SL-BA-DL	39	21	57.5	360	150
ICD60M-SM-BL-DL	39	21	57.5	360	150
ICD60M-SM-BM-DL	39	21	57.5	360	150
ICD60M-SM-BA-DL	39	21	57.5	360	150
ICD60M-SA-BL-DL	39	21	57.5	360	150
ICD60M-SA-BM-DL	39	21	57.5	360	150
ICD60M-SA-BA-DL	39	21	57.5	360	150

ICD60M Includes 3 Shelves L = Laminate M = Metal A = Acrylic

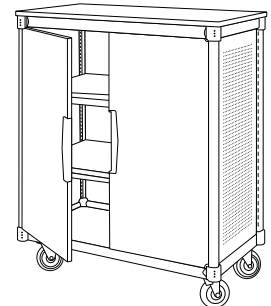



MOBILE CLASSROOM STORAGE

Additional storage is always needed in classrooms, makerspaces, libraries, & other learning spaces. Our line of Mobile Storage Cabinets consists of 2 options: Mobile General Storage, which is perfect for multiple applications & includes horizontal shelving storage. The Mobile Teacher Storage accommodates all the storage applications a teacher would need, along with a vertical section for hanging coats & other items.

FEATURES

STRUCTURE

Thermally fused melamine sides, back, & doors with matching 3mm edge-banding. 1-1/2" tubular steel frame with 3-point locking 12-gauge corner brackets on an all-welded steel frame reinforced base.

MOBILITY

5" super heavy-duty casters included on all units allow the storage cabinet to be easily moved around on various types of flooring.

LOCKING

Storage units lock securely with a key.

VARIETY

Mobile Classroom Storage is available in 2 different models - Mobile General Storage & Mobile Teacher Storage. Both units have plenty of shelf storage space, while the Mobile Teacher Storage also includes a vertical closet area to hang jackets & other items.



CONFIGURING A MODEL NUMBER

Refer to the Model Numbers and Product Specs section for a list of all family part model numbers in this product line. Use the chart below as a reference for how to properly specify this product.

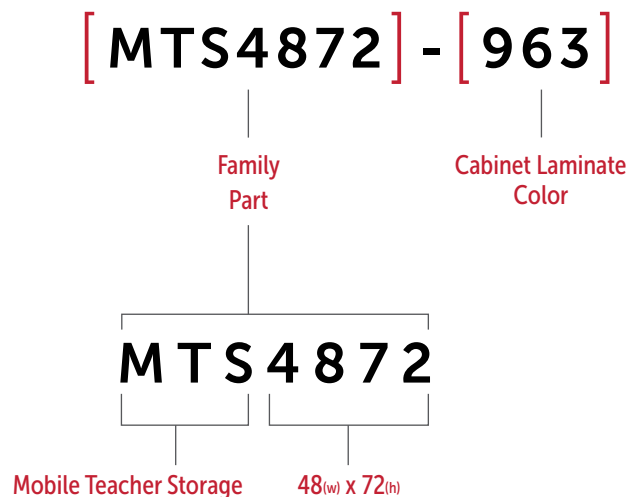

COLOR & FINISH OPTIONS

STEP 1 SHELVES & TOPS

Select one of the four colors
for **Step 1**

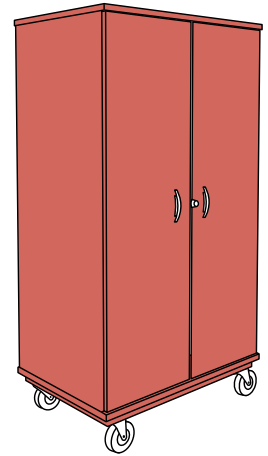

[FAMILY
PART] - [CABINET
COLOR]

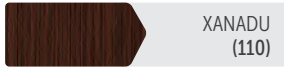

XANADU
(110)



STUDIO
TEAK (103)

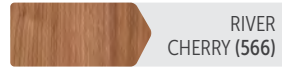

RIVER
CHERRY (566)

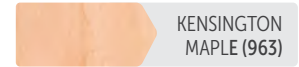

KENSINGTON
MAPLE (963)

MODEL NUMBERS & PRODUCT SPECS

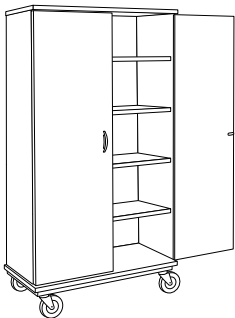

MOBILE GENERAL STORAGE

Model #	Width (in)	Depth (in)	Height (in)	Weight (lbs)	Freight Class (Qty 1)
MGS3672	36	24	72	440	250
MGS4872	48	24	72	450	250

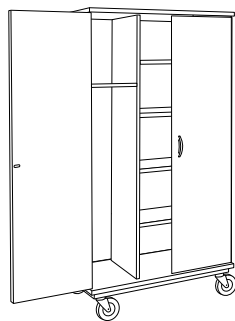

MOBILE TEACHER STORAGE

Model #	Width (in)	Depth (in)	Height (in)	Weight (lbs)	Freight Class (Qty 1)
MTS3672	36	24	72	440	250
MTS4872	48	24	72	450	250



INFORMATION COMMONS[®] CIRCULATION DESK

Paragon's Information Commons[®] Circulation Desk Series is the centerpiece of the Information Commons library. These configurable pieces have a cohesive design utilizing the same stylish flat oval tubing found in the Information Commons[®] library pieces as well as the workstations & reading table designed for your library space. Make your space complete by including optional free-standing storage components. These user-friendly pieces & attractive design will invite interaction between students, teachers & library staff.

FEATURES

Paragon Information Commons Circulation Desks are designed & manufactured specifically for educational environments. They are flexible, functional, durable, & look great too!

FRAME

Frames consist of fixed legs in 2 height options utilizing Information Commons flattened-oval steel tubing design with perforated steel modesty panels.

COMPONENTS

Information Commons Circulation Desk is made up of:

- Desk Shell
- Transaction Desk Shell
- Corner Radius
- Corner Radius Filler
- Book Return Module
- Depressible Book Cart

GLIDES OR CASTERS

Each component comes standard with glides & is available with casters as an option.

SHIPS KD

The IC Circulation Desk ships KD (knocked-down) to provide the most economical, damage-free shipping possible.

COLORS

Surface & modesty panel are available in numerous standard colors, & legs are available in Titanium powder coated steel.





Book Return Module



Corner Radius Filler



Desk Shell



Transaction Desk Shell



Corner Radius

CONFIGURING A MODEL NUMBER

The IC Circulation Desk can be configured in several different ways to create a custom Circulation Desk for your library or learning space. Each piece is ordered separately & can be specified in the following way. In this example we will use a desk shell with the model number: **CIRCDS603029**

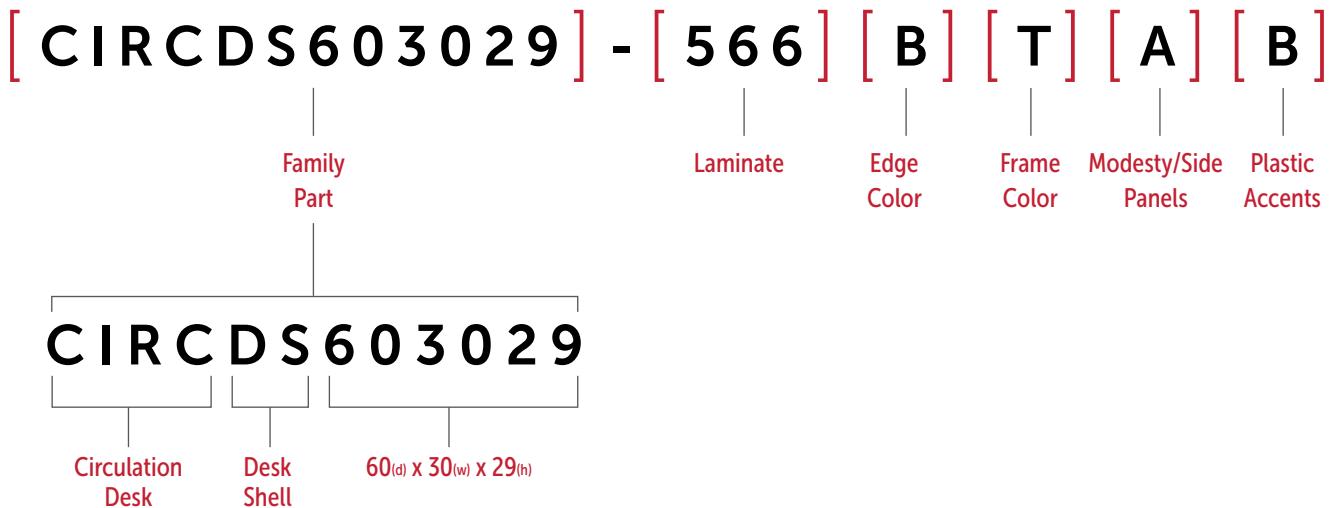







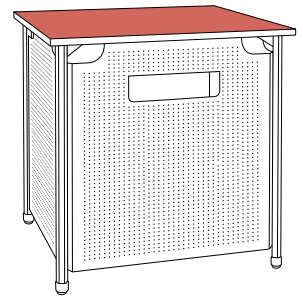









COLOR & FINISH OPTIONS

**STEP 1
WORK SURFACE**

[FAMILY] - [WORK SURFACE]
[PART]



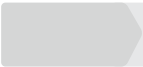







SOLID LAMINATE

 PARAGON RED (910)	 EARTH (185)	 FROST (918)	 CITADEL (303)
 MARS (743)	 STORM (770)	 NEUTRAL WHITE (123)	 NORTH SEA GRAY (535)
 CLEMENTINE (852)	 BLACK (900)	 FASHION GRAY (366)	 PLUM (736)
 ISLAND (229)	 COWBOY BLUE (976)	 FOLKSTONE (902)	 ORANGE GROVE (233)

WHITEBOARD LAMINATE

 MARKERBOARD WHITE (988)

WOOD GRAIN LAMINATE

 HIGH RISE (857)	 RIVER CHERRY (566)	 XANADU (110)	 WENGE STRAND (150)
 KENSINGTON MAPLE (963)	 STUDIO TEAK (103)	 WHEAT STRAND (179)	 BURNT STRAND (400)

PATTERN LAMINATE

 WHITE NEBULA (215)	 CARBON EV (890)	 CLASSIC LINEN (155)	 NAVY LEGACY (985)
 CRISP LINEN (122)	 CITADEL WARP (511)	 EARTHEN WARP (119)	 GRAPHITE TWILL (531)
 WASHI CRYSTAL (440)	 GRAPHITE NEBULA (994)	 EARTHEN TWILL (161)	 GRAY NEBULA (102)
 WASHI PEWTER (441)	 CLOUD NEBULA (315)	 SARUM TWILL (242)	 PRESSED LINEN (858)
 NEUTRAL WEFT (112)	 TAILORED LINEN (859)	 NEUTRAL TWILL (306)	

NEW COLORS



**STEP 2
EDGE**

[FAMILY] - [WORK SURFACE] [EDGE COLOR]

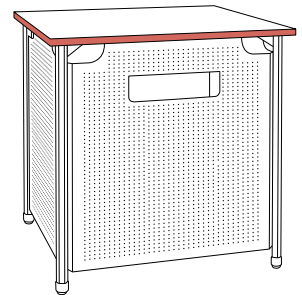
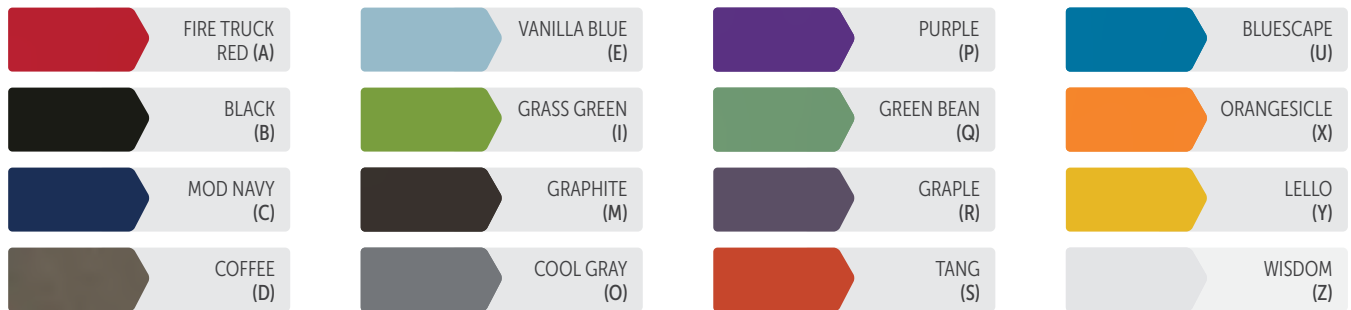

**STEP 3
FRAME**



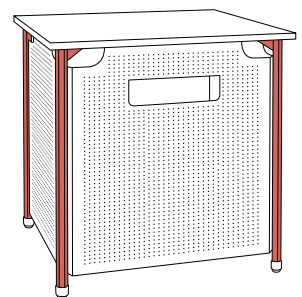



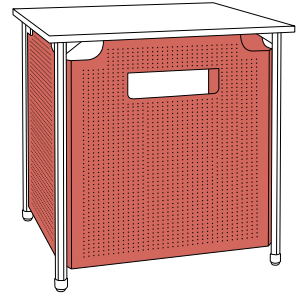





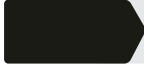

[FAMILY] - [WORK SURFACE] [EDGE COLOR] [FRAME COLOR]

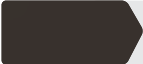

STEP 4 MODESTY/SIDE PANELS

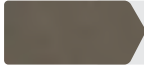

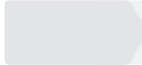
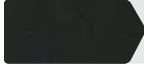





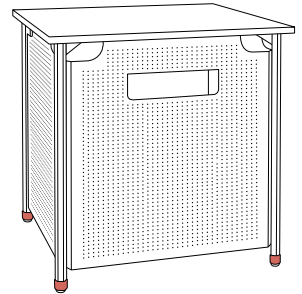







[FAMILY PART] - [WORK SURFACE] [EDGE COLOR] [FRAME COLOR] [**MODESTY/SIDE PANELS**]

 FIRE TRUCK RED (A)	 VANILLA BLUE (E)	 PURPLE (P)	 BLUESCAPE (U)
 BLACK (B)	 GRASS GREEN (I)	 GREEN BEAN (Q)	 ORANGESICLE (X)
 MOD NAVY (C)	 GRAPHITE (M)	 GRAPLE (R)	 LELLO (Y)
 COFFEE (D)	 COOL GRAY (O)	 TANG (S)	 WISDOM (Z)
 FLANNEL (F)	 TITANIUM (T)		

STEP 5 PLASTIC ACCENT

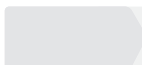

[FAMILY PART] - [WORK SURFACE] [EDGE COLOR] [FRAME COLOR] [MODESTY/SIDE PANELS] [**PLASTIC ACCENT**]

 FIRE TRUCK RED (A)	 VANILLA BLUE (E)	 PURPLE (P)	 BLUESCAPE (U)
 BLACK (B)	 GRASS GREEN (I)	 GREEN BEAN (Q)	 ORANGESICLE (X)
 MOD NAVY (C)	 GRAPHITE (M)	 GRAPLE (R)	 LELLO (Y)
 COFFEE (D)	 COOL GRAY (O)	 TANG (S)	 WISDOM (Z)

MODEL NUMBERS & PRODUCT SPECS

DESK SHELL

Model #	Width (in)	Depth (in)	Height (in)	Weight (lbs)	Freight Class (Qty 1)
CIRCDS403029	40	30	29	150	100
CIRCDS403029C	40	30	29	150	100
CIRCDS403629	40	36	29	160	92.5
CIRCDS403629C	40	36	29	160	92.5
CIRCDS603029	60	30	29	190	100
CIRCDS603029C	60	30	29	190	100
CIRCDS603629	60	36	29	200	100
CIRCDS603629C	60	36	29	200	100
CIRCDS723029	72	30	29	220	100
CIRCDS723029C	72	30	29	220	100
CIRCDS723629	72	36	29	230	100
CIRCDS723629C	72	36	29	230	100
CIRCDS403039	40	30	39	160	92.5
CIRCDS403039C	40	30	39	160	92.5
CIRCDS403639	40	36	39	170	92.5
CIRCDS403639C	40	36	39	170	92.5
CIRCDS603039	60	30	39	200	100
CIRCDS603039C	60	30	39	200	100
CIRCDS603639	60	36	39	210	100
CIRCDS603639C	60	36	39	210	100
CIRCDS723039	72	30	39	230	100
CIRCDS723039C	72	30	39	230	100
CIRCDS723639	72	36	39	240	100
CIRCDS723639C	72	36	39	240	100

(C at the end of the model number indicates casters)

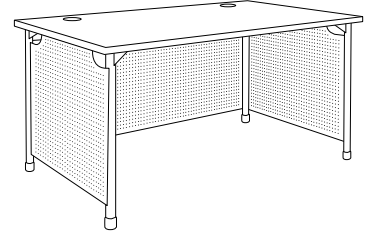

TRANSACTION DESK SHELL

Model #	Width (in)	Depth (in)	Height (in)	Weight (lbs)	Freight Class (Qty 1)
CIRCTDS603029	60	30	39	220	92.5
CIRCTDS603029C	60	30	39	220	92.5
CIRCTDS603629	60	36	39	230	92.5
CIRCTDS603629C	60	36	39	230	92.5
CIRCTDS723029	72	30	39	230	100
CIRCTDS723029C	72	30	39	230	100tl
CIRCTDS723629	72	36	39	240	92.5
CIRCTDS723629C	72	36	39	240	92.5

(C at the end of the model number indicates casters)

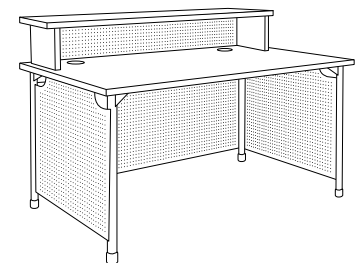

CORNER RADIUS

Model #	Width (in)	Depth (in)	Height (in)	Weight (lbs)	Freight Class (Qty 1)
CIRCCR723029	72	30	29	220	125
CIRCCR723029C	72	30	29	220	125
CIRCCR723629	72	36	29	230	125
CIRCCR723629C	72	36	29	230	125
CIRCCR723039	72	30	39	230	125
CIRCCR723039C	72	30	39	230	125
CIRCCR723639	72	36	39	240	125
CIRCCR723639C	72	36	39	240	125

(C at the end of the model number indicates casters)

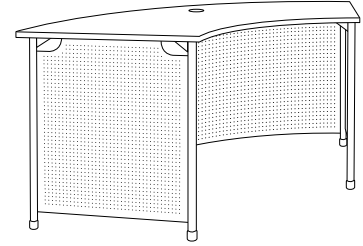

CORNER RADIUS FILLER

Model #	Width (in)	Depth (in)	Height (in)	Weight (lbs)	Freight Class (Qty 1)
CIRCCRF303029	30	30	29	140	100
CIRCCRF303029C	30	30	29	140	100
CIRCCRF363629	36	36	29	150	100
CIRCCRF363629C	36	36	29	150	100
CIRCCRF303039	30	30	39	150	100
CIRCCRF303039C	30	30	39	150	100
CIRCCRF363639	36	36	39	160	92.5
CIRCCRF363639C	36	36	39	160	92.5

(C at the end of the model number indicates casters)

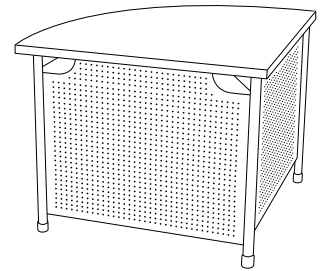

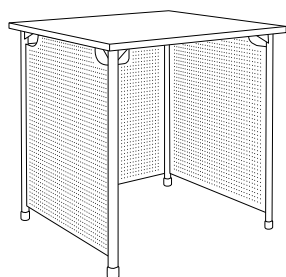

BOOK RETURN MODULE

Model #	Width (in)	Depth (in)	Height (in)	Weight (lbs)	Freight Class (Qty 1)
CIRCBR403029	40	30	29	150	100
CIRCBR403029C	40	30	29	150	100
CIRCBR403629	40	36	29	160	92.5
CIRCBR403629C	40	36	29	160	92.5
CIRCBR403039	40	30	39	160	92.5
CIRCBR403039C	40	30	39	160	92.5
CIRCBR403639	40	36	39	170	92.5
CIRCBR403639C	40	36	39	170	92.5

(C at the end of the model number indicates casters)

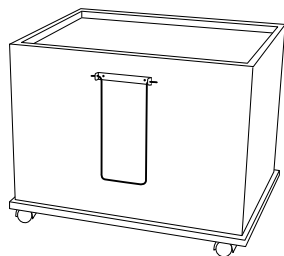

DEPRESSIBLE BOOK CART

Model #	Width (in)	Depth (in)	Height (in)	Weight (lbs)	Freight Class (Qty 1)
DBC	28.75	21.5	23.625	100	125

Available in the following laminates: Kensington Maple, River Cherry, Studio Teak, Xanadu, Folkstone, Frost, Black

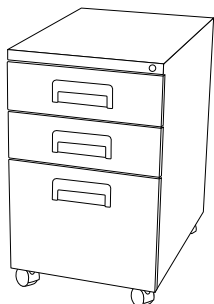

FILE-IT

Model #	Width (in)	Depth (in)	Height (in)	Weight (lbs)	Freight Class (Qty 1)
FILE-IT	15.5	21.5	25	80	125
FILE-IT-HANG	15.5	21.5	27	80	125

Available in standard FILE-IT colors. See page 163



INFINITY LIBRARY SHELVING

Paragon Furniture's Infinity Library Shelving stands the test of time. Classic, stylish & traditional, the shelving is offered using a starter/adder system that allows you to configure stacks as your environment needs. A variety of different shelving options available that include flat, magazine & picture book.

FEATURES

STRUCTURE

Constructed of heavy-duty 1" thick Thermally Fused Melamine (TFM) panels & shelves & reinforced with Steel Unitizer Braces for maximum durability.

INFINITY SHELVING WEIGHT CAPACITY (lbs)

	Single	Double
36"	180	360
42"	270	540
48"	270	540
60"	360	720
72"	450	900
84"	340	1080

WEIGHT CAPACITY PER SHELF

120 lbs.



SPECIFICATIONS

INFINITY WOOD SHELVING

Infinity Shelving is constructed of 1" thick industrial grade panel cores covered on both sides with Thermally Fused Melamine (TFM). All shelves are edge-banded on the front with 3mm PVC with a radius edge. Each shelf comes standard with a 16-gauge steel Deflecta-Stop anti-deflection stiffener that doubles as a book stop. Shelves are adjustable & secured to panels with 4 Posi-Lock connectors. All of these components increase the overall structural integrity of the shelving & help make Infinity Shelving the most sturdy & durable on the market.

STARTER & ADDER PANELS

All sizes are constructed of 1" thick industrial grade panel cores covered on both sides with TFM. Standard depth is 12" on Singles & 24" on Doubles.

EDGE TREATMENTS

Edges consist of matching 3mm PVC edge-banding with a smooth radius.

UNITIZER BRACE

The Unitizer Braces on all Infinity Shelves are truly unique & make this shelving the strongest on the market. Every Unitizer Brace is constructed of 18-gauge powder-coated cold-rolled steel for maximum strength & durability.

INFINITY METAL SHELVES

Infinity metal book shelves are constructed of 18-gauge cold-rolled steel & utilize the 16-gauge Deflecta-Stop anti-deflection stiffener which doubles as a book stop. Shelves attach to the panels using 5mm steel, bronze plated shelf supports.

MOBILE SHELVING

All Infinity mobile shelving have the same specifications & structural integrity as the Infinity shelving line with the addition of a 1" x 2" 18-gauge tubular continuous welded frame with black powder coat finish. 2 locking & 2 non locking 4" industrial grade rubber casters are available on 42"h & 48"h double faced shelving only.



CONFIGURING A MODEL NUMBER

Infinity Shelving is configured using a Starter/Adder concept. When configuring a shelving run, first select a Starter model number. Extend the shelving by adding additional Adder models as needed. In this example, we used part number **60-SFS-566**. The structure of this new part number can be broken up with parenthesis like this:

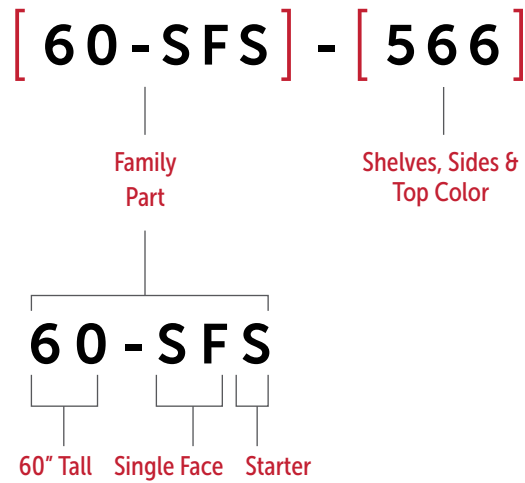

COLOR & FINISH OPTIONS

STEP 1 SHELVES, SIDES & TOP COLOR

Select one of the four color combinations. for **STEP 1**

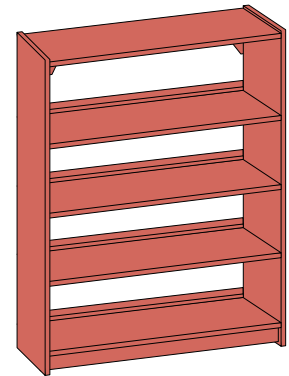

[FAMILY PART] - [SHELF, SIDES & TOP COLOR]

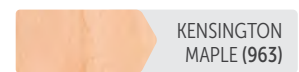
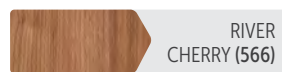

If ordering with metal shelves, they come paired with the following textured powder coat colors.

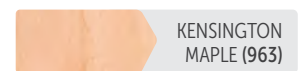
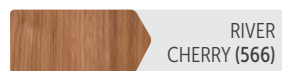

+

+

+

+

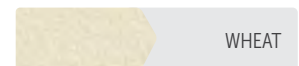

MODEL NUMBERS & PRODUCT SPECS

INFINITY-SINGLE STARTER

Model #	Width (in)	Depth (in)	Height (in)	Weight (lbs)	Freight Class (Qty 1)
36-SFS (2 Shelves)	37	12	36	110	85
36-SFSM (2 Shelves)	37	12	36	110	85
42-SFS (3 Shelves)	37	12	42	115	85
42-SFSM (3 Shelves)	37	12	42	115	85
48-SFS (3 Shelves)	37	12	48	120	85
48-SFSM (3 Shelves)	37	12	48	120	85
60-SFS (4 Shelves)	37	12	60	145	85
60-SFSM (4 Shelves)	37	12	60	145	85
72-SFS (5 Shelves)	37	12	72	165	85
72-SFSM (5 Shelves)	37	12	72	165	85
84-SFS (6 Shelves)	37	12	84	190	85
84-SFSM (6 Shelves)	37	12	84	190	85

M at the end of the model # is for metal shelves

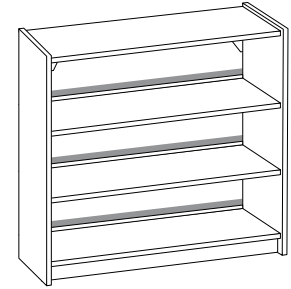

INFINITY-SINGLE ADDER

Model #	Width (in)	Depth (in)	Height (in)	Weight (lbs)	Freight Class (Qty 1)
36-SFA (2 Shelves)	36	12	36	95	85
36-SFAM (2 Shelves)	36	12	36	95	85
42-SFA (3 Shelves)	36	12	42	100	85
42-SFAM (3 Shelves)	36	12	42	100	85
48-SFA (3 Shelves)	36	12	48	105	85
48-SFAM (3 Shelves)	36	12	48	105	85
60-SFA (4 Shelves)	36	12	60	125	85
60-SFAM (4 Shelves)	36	12	60	125	85
72-SFA (5 Shelves)	36	12	72	140	85
72-SFAM (5 Shelves)	36	12	72	140	85
84-SFA (6 Shelves)	36	12	84	165	85
84-SFAM (6 Shelves)	36	12	84	165	85

M at the end of the model # is for metal shelves

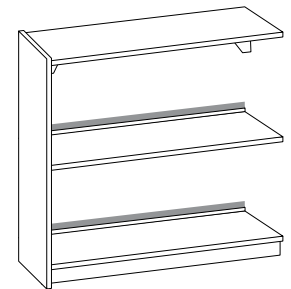

INFINITY-SINGLE PICTURE BOOK STARTER

Model #	Width (in)	Depth (in)	Height (in)	Weight (lbs)	Freight Class (Qty 1)
42-PBSFS (2 Shelves)	37	12	42	130	85
42-PBSFSM (2 Shelves)	37	12	42	130	85
48-PBSFS (3 Shelves)	37	12	48	130	85
48-PBSFSM (3 Shelves)	37	12	48	130	85

M at the end of the model # is for metal shelves

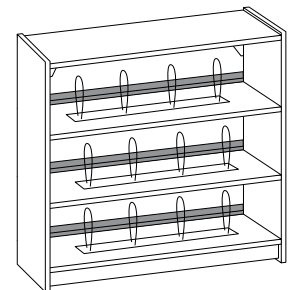

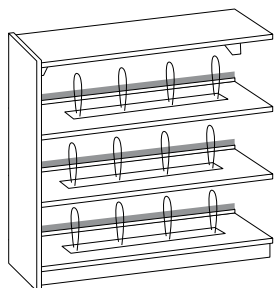

INFINITY-SINGLE PICTURE BOOK ADDER

Model #	Width (in)	Depth (in)	Height (in)	Weight (lbs)	Freight Class (Qty 1)
42-PBSFA (2 Shelves)	36	12	42	115	85
42-PBSFAM (2 Shelves)	36	12	42	115	85
48-PBSAS (3 Shelves)	36	12	48	120	85
48-PBSFAM (3 Shelves)	36	12	48	120	85

M at the end of the model # is for metal shelves

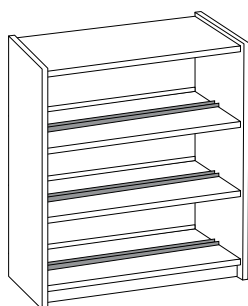

INFINITY-DOUBLE STARTER

Model #	Width (in)	Depth (in)	Height (in)	Weight (lbs)	Freight Class (Qty 1)
36-DFS (2 Shelves)	37	24	36	190	85
36-DFS _M (2 Shelves)	37	24	36	190	85
42-DFS (3 Shelves)	37	24	42	200	85
42-DFS _M (3 Shelves)	37	24	42	200	85
48-DFS (3 Shelves)	37	24	48	210	85
48-DFS _M (3 Shelves)	37	24	48	210	85
60-DFS (4 Shelves)	37	24	60	255	85
60-DFS _M (4 Shelves)	37	24	60	255	85
72-DFS (5 Shelves)	37	24	72	300	85
72-DFS _M (5 Shelves)	37	24	72	300	85
84-DFS (6 Shelves)	37	24	84	340	85
84-DFS _M (6 Shelves)	37	24	84	340	85

M at the end of the model # is for metal shelves

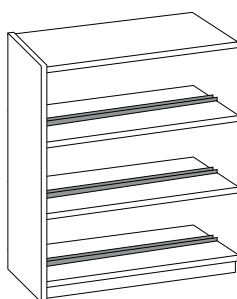

INFINITY-DOUBLE ADDER

Model #	Width (in)	Depth (in)	Height (in)	Weight (lbs)	Freight Class (Qty 1)
36-DFA (2 Shelves)	36	24	36	160	85
36-DFA _M (2 Shelves)	36	24	36	160	85
42-DFA (3 Shelves)	36	24	42	170	85
42-DFA _M (3 Shelves)	36	24	42	170	85
48-DFA (3 Shelves)	36	24	48	180	85
48-DFA _M (3 Shelves)	36	24	48	180	85
60-DFA (4 Shelves)	36	24	60	215	85
60-DFA _M (4 Shelves)	36	24	60	215	85
72-DFA (5 Shelves)	36	24	72	250	85
72-DFA _M (5 Shelves)	36	24	72	250	85
84-DFA (6 Shelves)	36	24	84	280	85
84-DFA _M (6 Shelves)	36	24	84	280	85

M at the end of the model # is for metal shelves

INFINITY-DOUBLE PICTURE BOOK STARTER

Model #	Width (in)	Depth (in)	Height (in)	Weight (lbs)	Freight Class (Qty 1)
42-PBDFS (2 Shelves)	37	24	42	225	85
42-PBDFSM (2 Shelves)	37	24	42	225	85
48-PBDFS (3 Shelves)	37	24	48	235	85
48-PBDFSM (3 Shelves)	37	24	48	235	85

M at the end of the model # is for metal shelves

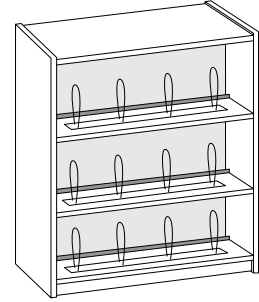

INFINITY-DOUBLE PICTURE BOOK ADDER

Model #	Width (in)	Depth (in)	Height (in)	Weight (lbs)	Freight Class (Qty 1)
42-PBDFA (2 Shelves)	36	24	42	195	85
42-PBDFAM (2 Shelves)	36	24	42	195	85
48-PBDAS (3 Shelves)	36	24	48	200	85
48-PBDFAM (3 Shelves)	36	24	48	200	85

M at the end of the model # is for metal shelves

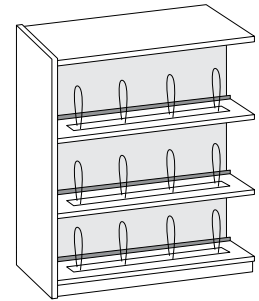

INFINITY-MOBILE SHELVING

Model #	Width (in)	Depth (in)	Height (in)	Weight (lbs)	Freight Class (Qty 1)
42-M-DFS (3 Shelves)	37	24	46	240	85
42-M-DFSM (3 Shelves)	37	24	46	240	85
48-M-DFS (3 Shelves)	37	24	52	230	85
48-M-DFSM (3 Shelves)	37	24	52	230	85

M at the end of the model # is for metal shelves

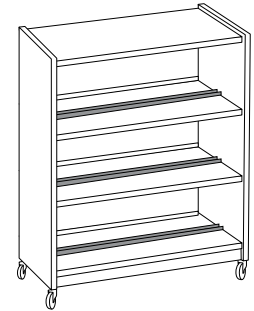

ACCESSORY BACK

Model #	Width (in)	Depth (in)	Height (in)	Weight (lbs)	Freight Class (Qty 1)
36-AB	37	3/4	36	55	85
42-AB	37	3/4	42	60	85
48-AB	37	3/4	48	65	85
60-AB	37	3/4	60	75	85
72-AB	37	3/4	72	90	85
84-AB	37	3/4	84	100	85

Accessory Backs are sold separately & are available for all Infinity Shelving

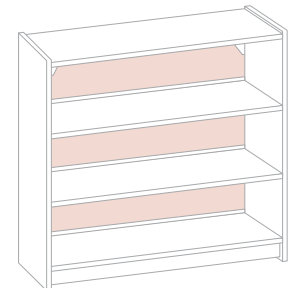

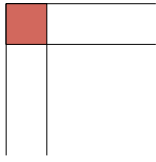

CORNER FILLER (FOR SINGLE FACE SHELVING)

Model #	Width (in)	Depth (in)	Height (in)	Weight (lbs)	Freight Class (Qty 1)
CFP	12	1	12	10	85

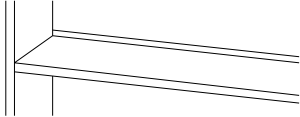

FLAT SHELF

Model #	Width (in)	Depth (in)	Height (in)	Weight (lbs)	Freight Class (Qty 1)
FSA	35	11	1	15	85
FSAM	35	11	1	15	85

M at the end of the model # is for metal shelves

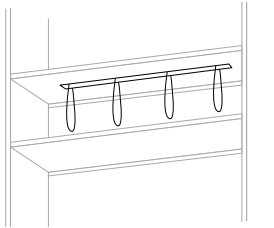

BOOK SUPPORT

Model #	Width (in)	Depth (in)	Height (in)	Weight (lbs)	Freight Class (Qty 1)
BSA	35	N/A	N/A	10	85

(Includes track & 4 wire supports) BSA cannot be used on metal shelves

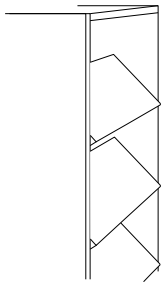

MAGAZINE SHELF

Model #	Width (in)	Depth (in)	Height (in)	Weight (lbs)	Freight Class (Qty 1)
MSA	35	11	1	15	85
MSAM	35	11	1	15	85

M at the end of the model # is for metal shelves

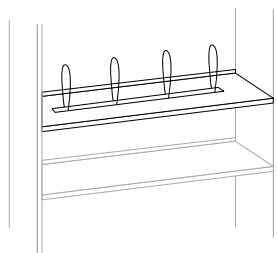

PICTURE BOOK SHELF

Model #	Width (in)	Depth (in)	Height (in)	Weight (lbs)	Freight Class (Qty 1)
PBSA	35	11	1	20	85
PBSAM	35	11	1	20	85

Part numbers include shelf as well as track & 4 wire supports. M at the end of the model # is for metal shelves.



INFINITY CIRCULATION DESK

Classic wood style design brings warmth to any space. Create a circulation desk with a variety of components that fit together seamlessly from work centers to corner units to book returns.

FEATURES

Paragon Infinity Circulation Desks are designed & manufactured specifically for educational environments. They are flexible, functional, durable, & look great too!

COMPONENTS

Infinity Circulation Desk is made up of:

- Desk Shell
- Desk Shell With Transaction Shelf
- Two Drawer Unit
- ADA Unit
- Corner Display
- Closed Corner Unit
- Working Corner
- Hinged Door Unit
- Open Storage
- Book Return
- Depressible Book Cart

SURFACE

1 ¼" High Pressure Laminate (HPL) top.

FRAME

Thermally Fused Melamine (TFM) sides & back with matching 3 mm PVC edge banding.

FEATURES

Cable Wire Management. Grommets & wire management channel.



CONFIGURING A MODEL NUMBER

The Infinity Circulation Desk consists of several different components that work together to create a workstation that is configured to your specifications. Each piece is configured separately & in this example, we start with the desk shell using model number **3260-DS-29** & the model number can be broken up with parenthesis like this:

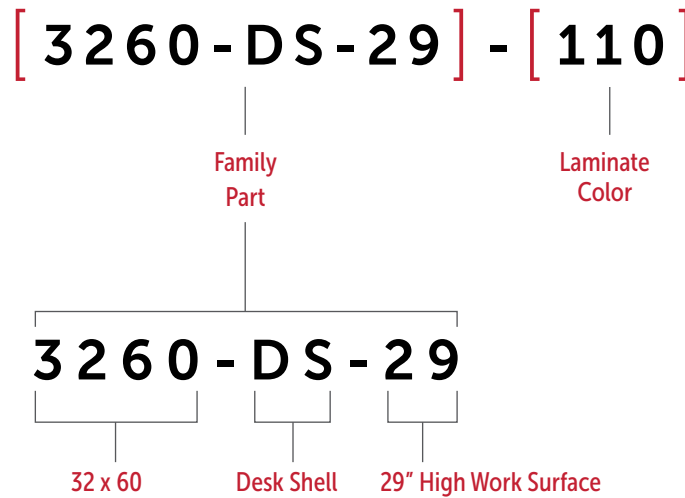

COLOR & FINISH OPTIONS

STEP 1 LAMINATE COLOR

Top, front, back, sides, & edge are all finished in the same laminate color. Specify one of the laminates below by using the number next to the laminate name.

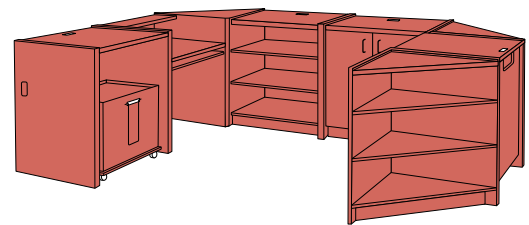

[FAMILY PART] - [LAMINATE COLOR]

◻ LAMINATE



MODEL NUMBERS & PRODUCT SPECS

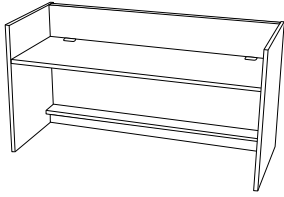

DESK SHELL

Model #	Width (in)	Depth (in)	Height (in)	Weight (lbs)	Freight Class (Qty 1)
3236-DS-29	36	30	32	175	85
3236-DS-32	36	30	32	175	85
3248-DS-29	48	30	32	220	85
3248-DS-32	48	30	32	220	85
3260-DS-29	60	30	32	250	85
3260-DS-32	60	30	32	250	85
3272-DS-29	72	30	32	270	85
3272-DS-32	72	30	32	270	85
3936-DS-29	36	30	39	195	85
3936-DS-32	36	30	39	195	85
3948-DS-29	48	30	39	230	85
3948-DS-32	48	30	39	230	85
3960-DS-29	60	30	39	265	85
3960-DS-32	60	30	39	265	85
3972-DS-29	72	30	39	300	85
3972-DS-32	72	30	39	300	85

-29 & -32 Indicate the work surface height. -29 Includes a privacy panel & -32 does not

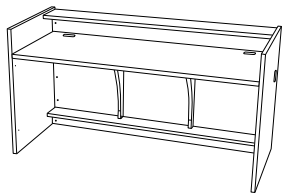

TRANSACTION DESK SHELL

Model #	Width (in)	Depth (in)	Height (in)	Weight (lbs)	Freight Class (Qty 1)
3936-TDS-29	36	30	39	215	85
3936-TDS-32	36	30	39	215	85
3948-TDS-29	48	30	39	250	85
3948-TDS-32	48	30	39	250	85
3960-TDS-29	60	30	39	295	85
3960-TDS-32	60	30	39	295	85
3972-TDS-29	72	30	39	330	85
3972-TDS-32	72	30	39	330	85

-29 & -32 Indicate the work surface height

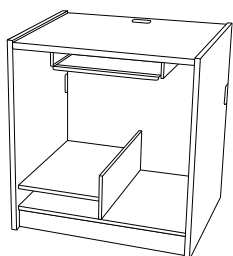

COMPUTER WORK STATION

Model #	Width (in)	Depth (in)	Height (in)	Weight (lbs)	Freight Class (Qty 1)
32-CWS	36	30	32	220	85
39-CWS	36	30	39	240	85

TWO DRAWER UNIT

Model #	Width (in)	Depth (in)	Height (in)	Weight (lbs)	Freight Class (Qty 1)
32-2D (1 Adjustable Shelf)	36	30	32	250	125
39-2D (1 Adjustable Shelf)	36	30	39	270	125

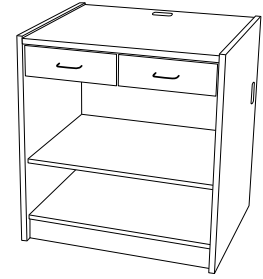

ADA UNIT

Model #	Width (in)	Depth (in)	Height (in)	Weight (lbs)	Freight Class (Qty 1)
32-ADA	36	30	32	130	85

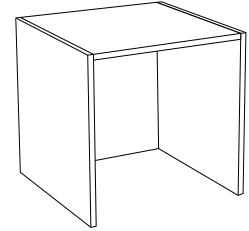

CORNER DISPLAY

Model #	Width (in)	Depth (in)	Height (in)	Weight (lbs)	Freight Class (Qty 1)
32-CD (1 Adjustable Shelf)	42	22	32	140	85
39-CD (2 Adjustable Shelves)	42	22	39	165	85

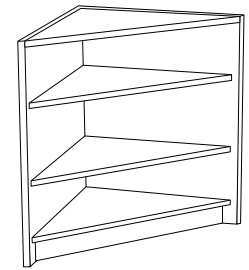

CLOSED CORNER UNIT

Model #	Width (in)	Depth (in)	Height (in)	Weight (lbs)	Freight Class (Qty 1)
32-CC	42	22	32	155	150
39-CC	42	22	39	175	150

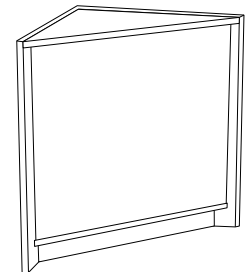

WORKING CORNER

Model #	Width (in)	Depth (in)	Height (in)	Weight (lbs)	Freight Class (Qty 1)
32-WC	66	36	32	250	85
39-WC	66	36	39	270	85

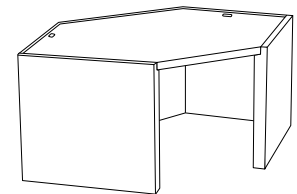

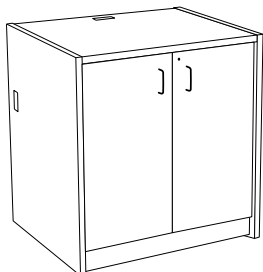

HINGED DOOR UNIT

Model #	Width (in)	Depth (in)	Height (in)	Weight (lbs)	Freight Class (Qty 1)
32-HD (1 Adjustable Shelf)	36	30	32	240	85
39-HD (2 Adjustable Shelves)	36	30	39	265	85

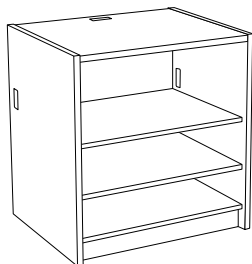

OPEN STORAGE

Model #	Width (in)	Depth (in)	Height (in)	Weight (lbs)	Freight Class (Qty 1)
32-OS (1 Adjustable Shelf)	36	30	32	215	85
39-OS (2 Adjustable Shelves)	36	30	39	255	85

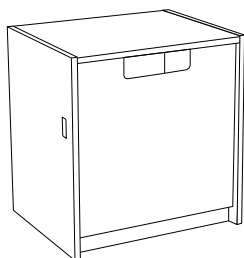

BOOK RETURN

Model #	Width (in)	Depth (in)	Height (in)	Weight (lbs)	Freight Class (Qty 1)
32-BR	36	30	32	175	85
39-BR	36	30	39	195	85

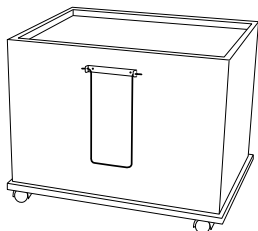

DEPRESSIBLE BOOK CART

Model #	Width (in)	Depth (in)	Height (in)	Weight (lbs)	Freight Class (Qty 1)
DBC	29	21.5	24	100	125

Available in the following laminates: Kensington Maple, River Cherry, Studio Teak, Xanadu, Folkstone, Frost, Black

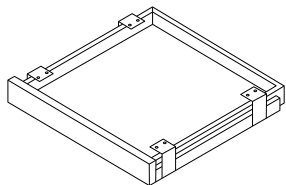

PENCIL DRAWER ACCESSORY

Model #	Width (in)	Depth (in)	Height (in)	Weight (lbs)	Freight Class (Qty 1)
PDA	17.5	17	3	10	85



MAKER™ IDEA BOARD

The Paragon MAKER™ Idea Board offers a canvas for interactive learning, brainstorming & connection. Move the board to a small group discussion to help ideate. Move the board to the front of the room to share the ideas with the larger group. Mobile, double-sided dry erase finish provides a large writing surface & perforated bottom panels allow for easy storage & access of tools & writing utensils.

FEATURES

There's an innate difference when you specify Paragon Furniture. We're dedicated to designing safe & ecofriendly furniture that lasts. Our products are tested to meet & exceed ANSI/BIFMA certifications, we are committed to complying with MAS Certified Green criteria & our products are assembled in the U.S.A.

◻ FRAME

The frame & leg assemblies are constructed from welded 16-gauge steel tube & the base is equipped with ¼" holes on 1" centers designed for standard pegboard hook accessories.

◻ MOBILE

All Idea Boards include 4 heavy-duty locking A&D Casters to move the board easily while in use, & remain stationary when necessary.

◻ FLEXIBLE

Idea Boards come standard with a white magnetic dry erase surface on both sides. Use as a mobile whiteboard or partition!

◻ STORAGE

The bottom half of the board is constructed using 16-gauge steel & is equipped with ¼" holes on 1" centers designed for standard pegboard hook accessories which allow for tools & writing utensils to be stored using optional ¼ inch peghooks.



CONFIGURING A MODEL NUMBER

Idea Boards can be configured in different sizes, colors, & styles, including a white markerboard surface. To specify white markerboard, use CWS. In this example we used model number **IDEABOARD3371-CWS** & the new part number can be broken up into parenthesis like this:

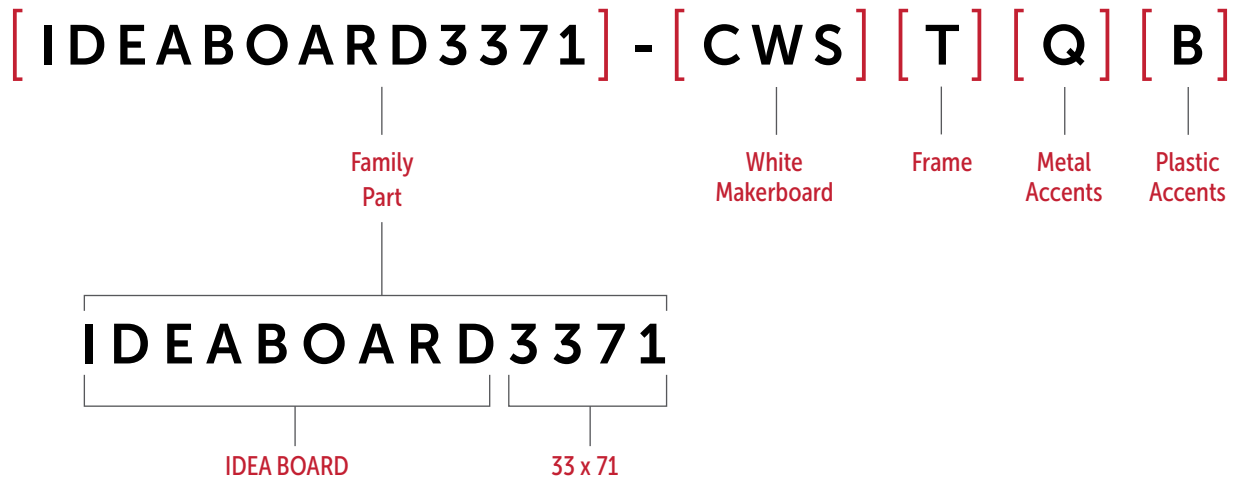

COLOR & FINISH OPTIONS

STEP 1 FRAME

[**FAMILY PART**] - [**FRAME COLOR**]

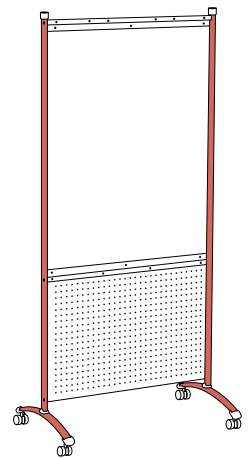

STEP 2 ACCENT PAINT

[FAMILY PART] - [FRAME COLOR] [METAL ACCENTS]

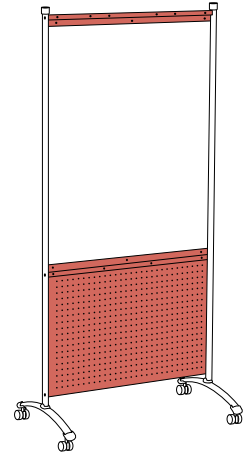
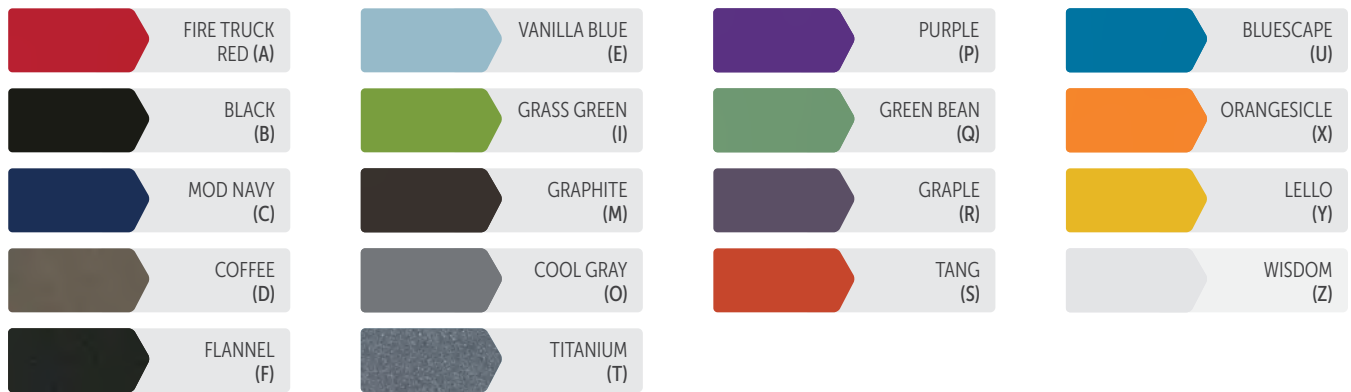

STEP 3 PLASTIC ACCENTS

[FAMILY PART] - [FRAME COLOR] [METAL ACCENTS] [PLASTIC ACCENTS]

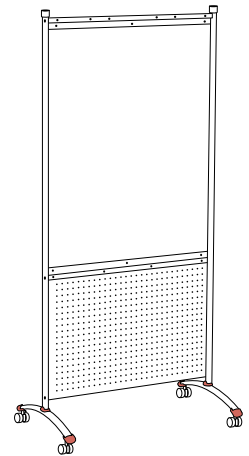
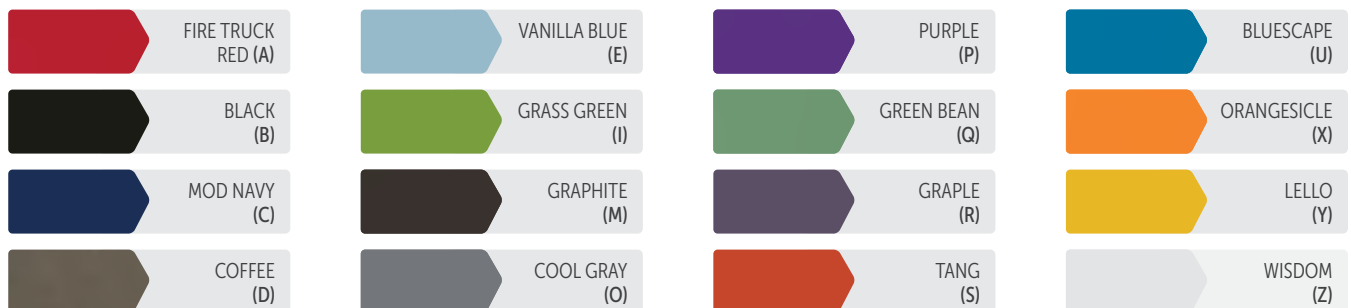

MODEL NUMBERS & PRODUCT SPECS

MAKER-IDEABOARD

Model #	Width (in)	Depth (in)	Height (in)	Weight (lbs)	Freight Class (Qty 1)
IDEABOARD3353-CWS	33	21	53	55	125
IDEABOARD3371-CWS	33	21	71	65	125
IDEABOARD7553-CWS	75	21	53	100	125
IDEABOARD7571-CWS	75	25	71	125	175
IDEABOARD3353-A15	33	21	53	55	125
IDEABOARD3371-A15	33	21	71	65	125
IDEABOARD7553-A15	75	21	53	100	125
IDEABOARD7571-A15	75	25	71	125	175

CWS specifies a white markerboard panel & -A15 specifies a clear acrylic panel

ACRYLIC PANEL DISCONTINUED

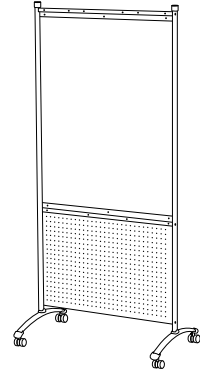



WORK HARD

DREAM BIG

EVERYTHING IS POSSIBLE







PARAGON™
FURNITURE

2224 East Randol Mill Road,
Arlington, Texas 76011

Toll Free Phone: (800) 451-8546

Phone: (817) 633-3242

Toll Free Fax: (888) 824-6494

Fax: (817) 633-2733

www.paragoninc.com

